

॥k 9/vi , YMZ e"e -'cbv

Quality Management in Education

EDM 3351

GgGW tcÖMög

-ç Ae GW#Kkb



eisj ॥ k D>gÿ ॥ १९५० ॥



This book is licensed under a
Creative Commons Attribution 4.0 International License.

འཛིན་བཟུང་གི་ལོ་འཛིན་

EDM 3351

འཛིན་བཟུང་གི་ལོ་འཛིན་

འཛིན་བཟུང་གི་ལོ་འཛིན་གྱི་ལོ་འཛིན་
འཛིན་བཟུང་གི་ལོ་འཛིན་གྱི་ལོ་འཛིན་
འཛིན་བཟུང་གི་ལོ་འཛིན་གྱི་ལོ་འཛིན་
འཛིན་བཟུང་གི་ལོ་འཛིན་གྱི་ལོ་འཛིན་
འཛིན་བཟུང་གི་ལོ་འཛིན་གྱི་ལོ་འཛིན་
འཛིན་བཟུང་གི་ལོ་འཛིན་གྱི་ལོ་འཛིན་

འཛིན་བཟུང་གི་ལོ་འཛིན་

འཛིན་བཟུང་གི་ལོ་འཛིན་གྱི་ལོ་འཛིན་
འཛིན་བཟུང་གི་ལོ་འཛིན་གྱི་ལོ་འཛིན་
འཛིན་བཟུང་གི་ལོ་འཛིན་གྱི་ལོ་འཛིན་
འཛིན་བཟུང་གི་ལོ་འཛིན་གྱི་ལོ་འཛིན་
འཛིན་བཟུང་གི་ལོ་འཛིན་གྱི་ལོ་འཛིན་

འཛིན་བཟུང་གི་ལོ་འཛིན་



འཛིན་བཟུང་གི་ལོ་འཛིན་གྱི་ལོ་འཛིན་
འཛིན་བཟུང་གི་ལོ་འཛིན་གྱི་ལོ་འཛིན་

EDM 3351

GgGll tclllg

cllklkj

cllg cllk: Mtmrt, 2002

clj: gyY: 2004, 2006, 2010

clj: gyY: Rlymyi, 2012

clj: gyY: Gicj, 2014

cll`

KvRx mvlbdlxb AveYm

KlrlDUvi KlrlR

tZldvtqj Avnsf

© eisl vt`k D:gy mekle`ij q

ISBN: 984-34-0063-1

cllkbiq

cllkbi, gyY l meZiY mefvm

eisl vt`k D:gy mekle`ij q

MvRlcj- 1705|

gyY

Avb>` mclEs tclh

30/1/K, tnfg>`a`vm ti vW

XvKv|

tKum@B AbyriY Kivi KuhRi ciugk©

ucq ukŋv_ŋ

Dgŋ ukLb c×uZ ubfP GgGW ukŋv tčMŋtg fivZ©nl qvi Rb" ŋz Ae GWžKkb AvcbriK AvšriK Awfb`b Rvbt"Q| ūkŋvi , YMZ e`e`icbū(EDM 3351) tKum@Biu Gg GW tčMŋgi 3q ŋtg÷vŋi tKvmŋgŋni Ašfŋ| , YMZ gvb ŋbqšŋYi ZvŋEK avi Ymn ukŋvŋŋtŋt , YMZgvb ŋbqšŋYi ŋwfbac×uZMZ I cŋqŋMK w`K GB tKvŋmP gj- cŋZcr` ŋelq|

ūkŋvi , YMZ e`e`icbūEDM 3351 tKum@B cW I Ablŋj tbi tŋtŋ Avcbri KiYŋq Kŋ?

- ŋkLb c×uZi gj- K_vB nj ŋbŋR ŋbŋR cŋo tkLv Ges ŋbŋRi tPŋvq tkLv| Ab" K_vq, G c×uZi gvatg ukŋv_xŋBR` ŋqŋZ; ŋbŋRi mŋeavgtZv mgŋq tkLvi KŋtR ŋbŋqŋRZ nb| e`Z G Dŋtŋk`ŋK mŋgtb tiŋLB ŋz Af GWžKkb Gi ŋwfbacKŋvŋmP eB, tŋv i ŋPZ| GŋZ fivMZ HK" iŋv Kŋi cŋvŋi ŋelqe`ŋK KZ, tŋv BDŋbŋU fivM Kiv nŋqŋQ| Avevi BDŋbU, tŋv ŋK KZK, tŋv cŋvŋ fivM Kiv nŋqŋQ| cŋZŋU cŋv cŋ_ŋgK fivŋe GKeri coŋZ Avcbri 40-45 ŋgubU mgq jMŋte etj aŋi tŋlqv nŋqŋQ| cŋZŋU cŋvŋi tŋtŋ Avcub ŋbŋRB ŋbŋRi cŋvŋi AMŋŋZ gj`vqb KiŋZ cŋiŋeb| G Rb" cŋZŋU cŋvŋi tŋtŋ cŋvŋvŋEi cŋŋgŋv Ges BDŋbU tŋtŋ iŋqŋQ Pŋvšl gj`vqb cŋŋgŋv|
- tKum@B covi mgq Kx Kx KŋtRi Dci , iazŋw ŋZ nŋe?
 - cŋvŋvŋEi gj`vqŋbi cŋŋgŋvi DŋEi ŋbŋR ŋbŋR Kiab| Avcbri DŋEi , tŋv mŋWK nj ŋK bv, Zv cŋvŋi tŋtŋ t`I qv ŋmŋWK DŋEi ŋtŋL hvPvB Kŋi ŋbb|
 - cŋvŋvŋEi gj`vqŋbi me, tŋv cŋŋkŋ DŋEi mŋWK nŋj Pŋvšl gj`vqŋbi cŋŋgŋvi DŋEi ŋbŋR Kiab| tŋtŋv³ cŋŋkŋ DŋEi , tŋv mŋWK nŋj cieZPBDŋbŋU GŋMŋq hŋb|
 - Avcbri DŋEi , tŋv mŋWK bv nŋj cŋv, tŋv Avevi cob| cov tkl nŋj cŋvŋvŋEi gj`vqŋbi cŋŋgŋvi DŋEi Kiab| DŋEi mŋWK nŋj ci cŋvŋ GŋMŋq hŋb|
 - tKivb cŋvŋ me, tŋv cŋŋkŋ DŋEi mŋWK bv nŋj tm cŋvŋi ŋbŋv ŋ Ask Avevi cob| Gfivŋe cŋZŋU BDŋbŋU cŋv, tŋv tkl Kiab|

eBiuŋZ th mg`ŋubŋ` Rbŋgŋ-K ŋPŋ e`eüZ nŋqŋQ tm, tŋv nj :



D×uZ



cŋvŋvŋEi gj`vqb



Pŋvšl gj`vqb cŋŋgŋv



mŋWK DŋEi

• cW-mŋŋqK KgŋmP

- ♦ ŋz Ae GWžKkb GB eBiu Qvovl ŋvbxq ŋUDŋUŋi qŋj tmUŋŋi Avcbri Rb" cŋZ gŋtm (2q-4_ŋA_ ev 1g-3q iŋŋeri) ŋŋU ŋUDŋUŋi qŋj Kŋŋmi e`e`v MŋY KŋiŋQ| Gme Kŋŋm thŋM w`ŋq Avcub eBiu coŋZ ŋMŋq tKivb mgm`vq coŋj ŋm ŋelŋq cŋŋqvRbxq ciugk© ŋbŋ`Rbv MŋY KiŋZ cŋvŋi| GQvovl Avcub miŋvŋi ŋz Ae GWžKkb-Gi tKvmŋgšŋKvixi mŋ½ thŋMŋthŋM Kŋi cŋŋqvRbxq ciugk©MŋY KiŋZ cŋvŋi|
- ♦ GQvovl ŋz Ae GWžKkb tiŋMVI I ŋUŋfŋZ cŋZ mBŋŋn Avcbri Rb" cŋvŋelqŋwŋEK Kŋŋmi e`e`v MŋY KŋiŋQ| Avcub ŋbaŋi Z mgŋq Nŋi eŋm Gme tmkŋb AskMŋY Kŋi mŋŋkŋ tŋtŋ Avcbri avi Yv mg× KiŋZ cŋvŋi|

մԻՔԻ

BDԻԲՍ	ԸՄԿ	ԸՊՆ
1	ՊՊՆԻ ՍՄԶԳՆ ԱՐԾ	01
1.1	ՊՊՆԻ ՍՄԶԳՆ	02
1.2	ՆՅՆ ՄՈՒՅՆ Ե՛Ե՛ՆԸԲՆ	06
1.3	ՊՊՆԻ ՄԻԳՄՈՒՔ ԳՆԸ ԸԲԳԲ Ե՛Ե՛ՆԸԲՆ	09
1.4	ՊՊՆԻ ԳՆԸ ԸԲԳԲ Ը՛ՔՊԸ	12
1.5	ՊՊՆԻ ԳՆԸ ԸԲԳՔԻ ԽԶԶԵԻ ԽԶՅԻ ՊԵՆԻԿ	15
1.6	ՊՊՆԻ ԳՆԸ ԸԲԳՔԻ ՊՊՆ՝ՔՔԻՆ՝Ք ԿՆԻԳՄ՝ՍՆ՝Բ	18
1.7	ՔԻՔՅԻ Յ ՊՊՊԿ, ԿԳՔԶՔԻ ԿԳՔՆԻՔ՝Ի ԿԳԸՄԻ ՔԵԿ ԳՅ՝ՎԳԲ	21
2	ՊՊՆԻ ԳՆԸ ԸԲԳԲ	25
2.1	ՊՊՆԻ ԳՆԸ ԸԲԳՔԻ ԱՎԱՅՈՒԿ ԱՐԻ ԿՆ	26
2.2	ՊՊՆԻ ԳՆԸ ԳՅ՝ՎԳԲ	29
2.3	ՊՊՆԻ ԳՆԸ ԸԲԳԲ	31
2.4	ԽԶԶԶԵԻ ՄՄԵՔ ՍՄԶ Ե՛Ե՛ՆԸԲՆ ԳՆՎՔՈՔ	35
2.5	ՊՊՆԻ ԳՆԸ ԸԲԳՔԻ ԱՔԵ՛Ն՝Ն ԻՔԿԻ Կ	37
2.6	ՊՊՆԻ ԸՆԶՕՆԻ ԽԻՔՊՔԻ ԸՈՒՐԻՅՈՒՅՆ	40
2.7	ՊՊՆԻ ԳՆԸ ԸԲԳՔԻ ՄԸԵ ՅՆԻ ԸԸՆ՝ՎԲԳՆ	43
2.8	ՊՊՆԻ ՍՄԶԳՆ Ի ԸՄԻ ԳՆԸ	46
2.9	ՊՊՆԻ ԳՆԸ ԽԽՈՅՔԻՔԻ ԿԼԸ-ԽԿԼՎՆԻ ԿԵՎՔՔՔԻ Ի ԸԲԳԲ	50
3	ՊՊՔԻ ԿԳՄ՝ՍՆ՝Բ ԳՅ՝ՎԳԲ	53
3.1	ԿԳՄ՝ՍՆ՝Բ ԳՅ՝ՎԳԲ : ԱՐԻ ԿՆ, ՅՆՐԸՊ՝ԸՔԻՔ՝ Ի ԸՄԶԳՅՆ Ն	54
3.2	ՊՊՔԻ ԿԳՄ՝ՍՆ՝Բ ԳՅ՝ՎԳԲ ԸՈՒՐՈՒՆ	59
3.3	ՊՊՔԻ ԿԳՄ՝ՍՆ՝Բ ԳՅ՝ՎԳՔԻ Յ՝՝ ԸՐՄ	65
3.4	ԿԳՄ՝ՍՆ՝Բ ԳՅ՝ՎԳՔԻ ՄԳՄՆ ԳԵՏ ԳՎՆՎԲԳԲ	69
4	ՊՊՆԻ ՍՄԶԳՆ ԽԽՈՅՔԻՔԻ ԿԳՔՈՒՅՆ	75
4.1	ԿԳՔՈՒՅՆ : ԱՐԻ ԿՆ, ԸՔԻՔ՝, ԸՄԻ ՄԻ, ՊԵԼՈՒ ԳԵՏ ՍԻՅԻ	76
4.2	ԿԳՔՈՒՅՆ ԸՈՒՐՈՒՆ ԸՄԵ ՅՆԻ ԸԸՆ՝ՎԲ Ի ԸՈՒՐՈՒՆ	80
4.3	ՊՊՆԻ ԸՆԶՕՆԻ ԱԲ՝ՏԻՔԻ ԿԳՔՈՒՅՆ ԽԿՔԵԵ	84
4.4	Ե՛Ն՝Յ ԸՈՒՐՈՒՆ ՊՊՔԻՔ՝ Ի ԿԳՔՈՒՅՆ ԽԿՔԵԵ	88
4.5	ԿԳՔՈՒՅՆ ԿՆԻՔՆԻ ԳՅ՝ՎԳԲ ԳԵՏ ՍՄԶ ՄՔԿ	92

Ի՞նչ է ՍՄԶԳՆ ԱՐԾ

[Quality of Education and Achievement of it's Standard]

Բնութագր

Ի՞նչ է ՍՄԶԳՆ ԱՐԾ ինչպես է սահմանվում և որն է նրա նպատակը Ի՞նչ է ՍՄԶԳՆ ԱՐԾ-ի նպատակը և ինչպե՞ս է նրան հասնելու համար

Ի՞նչ է ՍՄԶԳՆ ԱՐԾ-ի նպատակը և ինչպե՞ս է նրան հասնելու համար Ի՞նչ է ՍՄԶԳՆ ԱՐԾ-ի նպատակը և ինչպե՞ս է նրան հասնելու համար

- cW - 1.1 Ի՞նչ է ՍՄԶԳՆ
- cW - 1.2 Նշանակությունը
- cW - 1.3 Ի՞նչ է ՍՄԶԳՆ-ի նպատակը
- cW - 1.4 Ի՞նչ է ՍՄԶԳՆ-ի նպատակը
- cW - 1.5 Ի՞նչ է ՍՄԶԳՆ-ի նպատակը
- cW - 1.6 Ի՞նչ է ՍՄԶԳՆ-ի նպատակը
- cW - 1.7 Ի՞նչ է ՍՄԶԳՆ-ի նպատակը

cW 1.1

uk`vi , YMZgub

[Quality of Education]

Df`k`

GB cW tk`l Av`b –

- uk`vi , YMZgub uk` enstq ej`z cvi`eb Ges
- uk`vi , YMZgub i weifbaw`K Av`j vPbv Ki`z cvi`eb |

uk`vi , YMZgub

uk`vi gub i c`k`z. m`u`K`A`b`K gZvgZ i`q`Q | Avevi uk`vi , YMZgub i ms`Av weifbaw`k`l`A weifbaw`v`e i`t`q`Qb | A`b`k`B uk`vi gub ej`z ce`baw`i`Z gub i m`š`l`R`b`K m`v`k` ev` i`g`j` k` enstq`Qb |

uk`vi gub i`K` i`Z`b`u` Aw`z`k` wePvi Kiv nq – (K) gub i`b`w`D`Z`K`i`Y (Quality assurance), (L) ce`baw`i`Z gub i`Z`j` (Contract conformance) Ges (M) `v`Z`v`-M`h`v`Z`vi P`w`n`v` c`i`f`Y (Customer-driven) mg_`p`

gub i`b`w`D`Z`K`i`Y

(K) gub i`b`w`D`Z`K`i`Y: uk`vi gub i`b`w`D`Z`K`i`Y ej`z uk`vi K`v`r`L`Z` gub AR`B` K`i`v`k` t`e`v`S`v`q | GB K`v`r`L`Z` gub nj` Av`š`R`i`Z`K`f`v`e uk`sev Av`A`ij` K`f`v`e Z`j` gub hv` th`v`M` uk`v`K, Av`aj`b`K uk`v`l`v`g, h`_`v` uk`v`Y c`x`i`Z Ges c`l`q`v`R`b`x`q c`w`i`t`e`k Ges av`i`v`e`v`n`K c`w`i`e`x`v`i`f`Y`i` g`v`a`t`g Av`R`Z` n`q | GB K`v`r`L`Z` gub we`A` i`e`l`q`v`f`i`E`K` c`u`O`Z, uk`v`i`v` we`A`v`b`x Ges ms`u`k`w` th`v`M` t`j`v`K` Ø`v`i`v` i`b`a`w`i`Z` n`q | D`v`n`i`Y`-t`f`c` ej`v` hv`q` K`i`v`u`D`U`v`i` t`c`u`M`t`g`i` m`a`š`b` ch`i`q`i` gub uk`f`v`e i`b`w`D`Z` K`i`v` hv`q` Gi` R`b` c`l`q`v`R`b` c`i`v`e`x`i` weifbaw`t`k`i` Ges t`m`B` m`v`t`_` i`b`R`-^`A`A`t`j`i` weifbaw`uk`v`i`v` c`u`Z`o`v`b` K`Z`R` c`w`i`P`w`j`Z` K`i`v`u`D`U`v`i` m`v`t`q`Y` t`c`u`M`t`g`i` gub hv`P`v`B` K`i`v` t`-t`k`i` uk`v`i`K`i`v` H` i`e`l`q` c`o`v`t`Z` m`v`j`g` uk`b`v` Z`v` L`v`t`q` t`-L`v` Ges G` i`e`l`t`q` c`i`v` v`t`b`i` h`i`e`Z`x`q` D`c`K`i`Y` m`š`M`h`, m`š`i`v`v` Ges K`i`v`R` j`v`M`v`t`b`v`i` m`a`e`-Z`v` hv`P`v`B` K`i`v` i`e`l`q`v`i`v` ms`u`k`w` uk`v`i`v` c`u`Z`o`v`t`b` c`i`v` v`t`b`i` e`-e`-v` K`i`v` | gub i`b`w`D`q`Z`v` weav`t`b`i` m`v`t`_` gub m`a`u`i`K`Z` c`P`v`i` Avek`K` | Gi` d`t`j` hv`P`v`B` i` i`b`i`x`v`i`v` m`a`e` Ges Z`v`i` M`h`Y`t`h`v`M`-Z`v` uk`v`i`K` i` uk`v`i`v`_x`m`g`v`t`R` m`g`v`-Z` nevi` m`a`e`b`v` t`e`i`k` |

gub i`b`w`D`Z`K`i`Y weifbaw`c`k`v`i` Ab`k`v`j` t`b`i` g`v`a`t`g` K`i`v` n`q, t`h`g`b`- uk`v`i`K` g`j`-v`q`b` c`x`i`Z` | uk`v`i`t`k`i` gub D`b`z` n`t`j` uk`v`i`v` gub Aek`B` evote | we`A`R`b`i`v` e`t`j`b, Ø`No method of education is better than it's teachers` | Z`v`B` D`b`z` t`-t`k` we`k`l`f`v`e` c`v`i`-k`x` c`w`i`E`Z`g`E`j`x` uk`v`i`K` g`j`-v`q`t`b`i` c`k`e`I` `Z`v`i` K`i`v` h`v`i` g`t`a` Av`k`-Ges K`i`v`R`i`x` uk`v`i`t`k`i` , Y`v`e`j` m`a`u`i`K`Z` c`- A`š`f`Z` K`i`v` n`q | m`v`P`v`S`Z`f`v`e` c`k`e`-Z`v`i` n`t`j` c`i`x`v`i`v`i` g`v`a`t`g` h`_`v`-Z`v` hv`P`v`B` K`i`v` hv`q` | i`b`e`P`Z` uk`v`i`K`-i`k` G`_t`j`v`i` e`-envi` m`a`u`i`K`-c`k`v`i`Y` t`-l`q`v` n`q | e`-Z`c`f`v` GB` t`U`-t`j`v` uk`v`i`K`-i` Av`P`i`Y` Ges K`i`v`h`e`x`i`Z` c`w`i`g`v`t`c`i` K`j`v`t`K`š`k`j` i`n`t`m`t`e` K`i`v`R` K`i`v` | GB`f`v`e` hv`P`v`B`K`Z` uk`v`i`K`i`v`B` D`b`z` t`-t`k` f`i`Z`P` R`b` uk`v`i`v`_x`m`g`v`t`R` K`i`v` | m`K`j` uk`v`i`v`_x`P` R`b` G`K`B` ai`t`b`i` c`k`e`t`m`U` K`i`v` n`q` Ges uk`v`i`v`g` i` uk`v`i`v`m`P` c`w`i`t`e`k` t`f`t`- uk`Q`y`Av`j`v`v` n`t`j` i` g`j`-av`i`Y`v` Ges Ab`v`b` c`u`Z`c`v`- i`e`l`q` GK`_v`t`k`, h`v`i` d`t`j` D`b`z` t`-k`_t`j`v`t`Z` uk`v`i`v`t`v`t`i` g`v`b`m`a`Z` uk`v`i`v`_x`t`c`k`i`M`Z` -v`i`Z`v`

`vZv Ges MõxZvK Ggbfite Kvh[©]xvZ ubaPj KiZ nte thb hviv GLbl G çµqvq Avfmb Zvivl DckZ.nb| ubtge `vZv-MõxZv Pµ nZ nel qvU Avfiv cwi[©]vi nte|

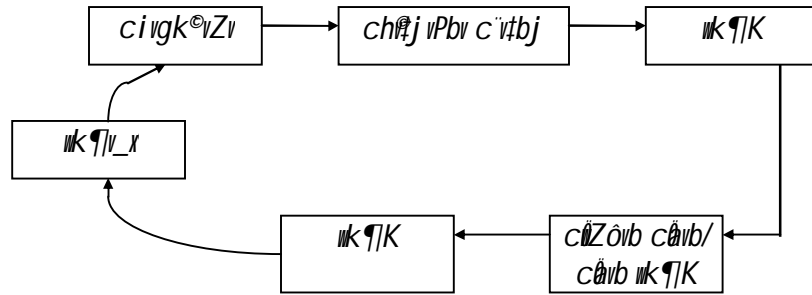

uPÎ 1.1-1 : `vZv-MõxZv Pµ

cZõvb cãvb / cãvb wkK KZ[©] ubt`KZ nte wkK Zvi cV`vb l Avbly[©] mKj KvhPjg cwiPj bv Ktib| wkK_x[©]KZU[©]z[©]wkL[©]Z cvij Ges Zvi AvPi[©]Yi KZU[©]z[©] cwi[©]eZ[©] NUj tm m[©]ú[©]K[©]civgk[©]vZv (counsellor) gZvgZ w`tq chPj vPbv c`vbj cV`vte| c`vbj Avei Zv Kvh[©]Ri Kivi Rb` cZõvb cãvb/cãvb wkK[©]K Rv[©]vte| wkK[©]vi gvb Dbq[©]bi Rb` GB arive[©]mnK Pµ AZ`š[©]Kvh[©]Ri etj ç[©]ymYZ|

wkK[©]vi e`v h[©]Mc[©]thvMx Ges Kvh[©]Ri Kivi Rb` wkK[©]vi[©]g cwiK[©]í[©]bv A[©] P[©] ms[©]ik- ó miK[©]vi ms[©]vmg[©], c[©]Y[©] K[©] tjLK, c[©]Y[©] c[©]K[©]vkK, c[©]Y[©] me[©]µ[©]Zv, cZõvbK M[©]š[©]vi, we`ij q cwiPj bv Kvg[©]U, wkK[©]g[©]U[©]ij, AvffieK Ges wkK[©]vi[©]KnK[©]tj B R[©]oZ| mK[©]tj i gta`fvj m[©]ú[©]K[©]i[©]tl KvR Kivi gra[©]tg`z M[©]z[©]Z wkK[©]vi gvb Dbq[©]b Kiv m[©]e|

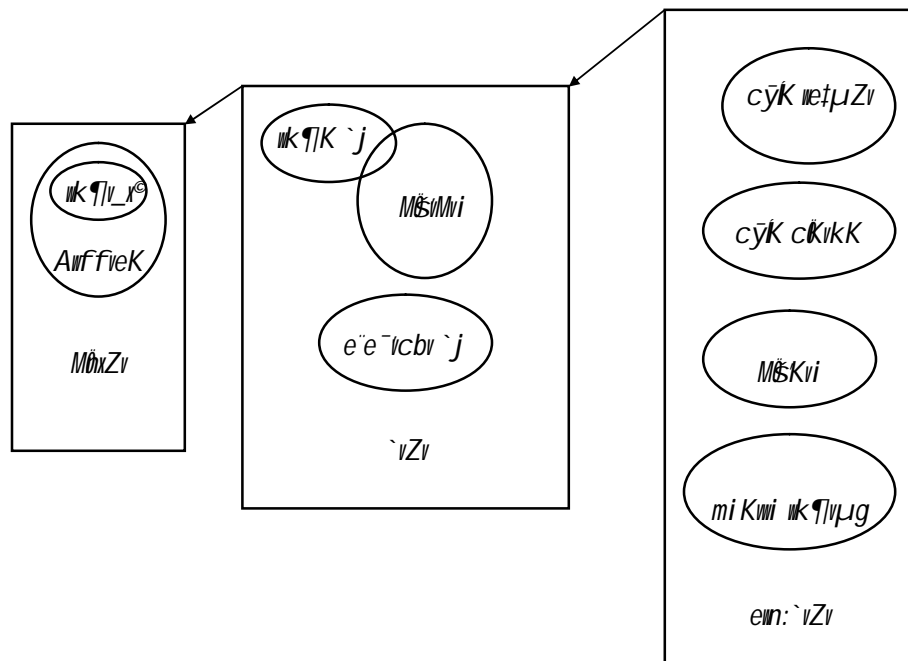

uPÎ 1.1-2 : `vZv-MõxZv Pµ



cv#VvEi gj`vqb 1.1

A) eú ubePbx cĕæ

m#WK DĒi ubt` Rgj-K AŋiWtK eĒvqZ Kiab | (D`vniY: Avcbvi ubePZ DĒiW K ntj GtK Ⓚ eĒvqZ Kiab)

1/ wkŋvi gvb ej tZ WK tevSvq ?

- (K) AvšR#ZK fite` tKZ.gvb
- (L) AvĀwj Kfite` tKZ.gvb
- (M) wkŋv msukó ce#ba#i Z gvb
- (N) cĀZóvb cĀvb KZĒ ba#i Z gvb

2/ wkŋvi gvb hvPvBtqi cšv tKvbW ?

- (K) AvšR#ZK cĕæ#YZvi gra`tg cixŋvi e`e`v Kiv
- (L) ba#i Z cixŋv KugW ōiv cĕæcĕvqb Kiv
- (M) Kvhŋtĭ wkŋv_x# i mdj Zv hvPvB
- (N) KvhR#i cšvq wkŋtKi gvb hvPvB

3/ `vZv-MōxZv Ptμ me#Ptq KvhRix ubt` Rbv tK t`b ?

- (K) cingk#vZv
- (L) chŋj vPbv c`v#bj
- (M) cĀvb wkŋK
- (N) wkŋK

Av) msuŋB DĒi cĕæ

1. wkŋvi gvb ej tZ WK tevSvq ?
2. wkŋvi gvb WK WK Av#tK wePvi Kiv nq ?
3. Pvn`v ci-Y WK ?
4. WK WK fite wkŋvi gvb ub#Z Kiv hvq ?

B) iPbvqj-K cĕæ

1. wkŋvi gvb ub#ZKiY cĀuqv eYōv Kiab |
2. `vZv I MōxZvi Pvn`v ci-Y WK fite m#e ?

m#WK DĒi:

A) 1| M 2| N 3| L|

cW 1.2

`vZv-MhXZv e`e`vcbv

[Management of Manager and Customer]

Df`ik`

GB cW tk`I Avicib-

- **ik`qvi gvb Dbq`b m`ut`K`e`vL`v w` t`Z cvi`teb;**
- **MZvbMhXZK I Avay`bK ik`qvi e`e`vcbvi cv`R` w`bY`q Ki`t`Z cvi`teb Ges**
- **ik`qvi gvb Dbq`t`bi t`K`S`kj , t`jv Av`j v`P`bv Ki`t`Z cvi`teb |**

YMZ ik`qvi mgv`f`Ri me`f`i i gvb`f`i i m`v`f`ij Z c`P`ovi dj | Avgiv h`w` a`ti tbB `f`z, K`f`j R, mekpe`ij q `vcb K`ti ik`q`K w`b`q`v`M Ki`t`j`B t``k , YMZ g`v`t`bi ik`q`v `Z: `u`Z`f`v`te c`P`w`j Z n`te Zv n`t`j ik`q`vi , YMZ g`v`b KL`f`b`v`B w`b`w`o`Z Kiv m`e`e n`te b`v | Avgv`f`i g`Z Dbq`b`k`j t``k Avgiv GK`U`v a`v`f`i a`v`i`Y`v t`c`v`l`Y` K`v`i , ik`q`v c`u`Z`o`v`b `f`v`e`Z`B Db`z g`v`t`bi ik`q`v t``q, m`z`i`v`S` t`K`v`b`i`K`g w`b`c`w`q`K t`h`v`M`v`t`h`v`t`M`i c`u`q`v`R`b` t`b` | w`K`S``t`h` m`K`j t``k ik`q`v`q Db`z Z`v`f`i t`q`f`t` w`el`q`w` G`f`K`e`v`t`i w`f`b`q` H` m`K`j t``k`i c`u`Z`w` b`v`M`i`K` m`f`b`t`i` A`v`b`v`R`f`b`i g`v`t`v` , c`u`q`v`M`K` w`K` I f`v`e`l`f`z`i w`P`f`l`v`i`t`K` m`g`f`q` K`f`i ik`q`v c`u`Z`o`v`t`b ik`q`v t``l` q`v n`f`"Q` w`K`b`v` Z`v` Z`v`i`v` w`e`f`k`d`Y` K`f`i Ges c`u`Z`o`v`t`b t`m` me` w`P`f`l`v`i`v`i c`u`Z`d`j`b` N`U`v`t`b`v`i` R`b`" me`v` g`Z w`e`l`b`g`t`q`i` g`v`a`f`g` m`f`P`o`_v`t`K` | Z`v`i`v` M`Z`v`b`M`h`X`Z`K` c`x`w`Z` e`v` w``t`q` A`v`a`y`b`K` c`x`w`Z` A`e`j``v`b` K`f`i ik`q`vi m`v`g`v`M`K` g`v`b` Dbq`t`b` m`f`P`o` | ik`q`v`i`f`t`b` ik`q`K` , c`u`Z`o`v`b` c`v`i` P`v`j` b`v` K`Z`e`q` , c`i`v`g`k`e`v`Z`v` , g`t`b`v`P`v`K`r`m`K` m`K`f`j` B `v`Z`v` A`v`i` ik`q`v`_x` , A`w`f`f`v`e`K` M`h`x`Z`v`i` f`v`g`K`v`q` K`v`R` K`f`i | w`b`t`g`e`w`ik`q`vi` m`v`g`v`M`K` g`v`b` Dbq`b` e`e`vcbvi` M`Z`v`b`M`h`X`Z`K` Ges` A`v`a`y`b`K` A`e`-`v`b` `w`d` w`c`i`v`g`f`W`i` m`v`v`t`h`" t``L`v`t`b`v` n`j` |

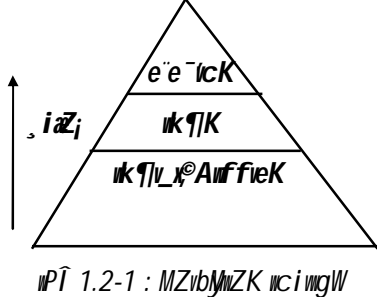

w`P`f` 1.2-1 : M`Z`v`b`M`h`X`Z`K` w`c`i`v`g`W`

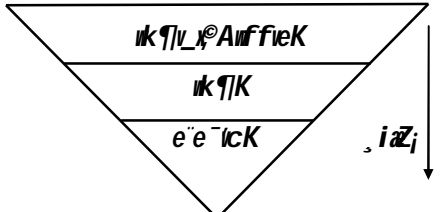

w`P`f` 1.2-2 : D`b`z` e`e`vcbvi` w`c`i`v`g`W`

G`w`c`i`v`g`W` `w`d` t``t`K` e`S`v` h`v`q` M`Z`v`b`M`h`X`Z`K` e`e`vcb`v`q` e`e`vc`K` (A`a`"q`/` c`a`v`b` ik`q`K`/` D`c`v`P`v`h`" me`D`c`f`i` A`v`i` ik`q`v`_x` I` A`w`f`f`v`e`K` me`b`t`g`e`Ges` ik`q`K`i`v` g`a`"L`v`t`b` t``t`K`

e'e-vcK thgbfite Pjvb tZgubfite Pjtb| GLvib MhvxZvK e'e-vcKki mg-
wvšl tgb Pjtz nq Ges AwffveK I ukᶒv_xp fvgKv (tμZv) AZ"šl tMSY|
cᶒvšti ukᶒvi AvaybK e'e-vcbrq t`Lv hvq AwffveK, ukᶒv_xfv meMÖMY| uk
aitbi ukᶒv e"v³, mgvR I t`tki Dbqtb cöqvRb G wPštfivebv tμZv A_ᶒ
AwffveK I ukᶒv_xp i wBKU t`tK Avtm| e'e-vcK cöZövb cwiPjv bv KZᶒtᶒi
mnvqZvq ukᶒvμg, civ"mip I AvblywK cöwZ m"ubaGes mgtqvcthvMx Kti _vtKb|

**ukᶒvi ᶒMZgvb I
tKŠkj**

ukᶒvi ᶒMZgvb AtbKuv tKŠkj wbfᶒ| me tKŠkj meᶒᶒtᶒ cöhvR" bq| wbtP Pviw
tKŠkj Avtj vPbv Kiv nj -

- **eW temW gᶒ tKŠkj (Broad Based Open Technique):** G tᶒtᶒ ukᶒvμg nq
e'vcK| G ukᶒvμtg gvb Dbqtb msμvšl w`K wbt`Rbv _vtK| miKvi / miKvi
wb tqwRZ ms`v G ukᶒvμg `Zvi i mgq ukᶒvi Dti`k", ukLbdj Ges ukᶒvi gvb
m"uukᶒ MvBwj vBb wbaᶒi Z nq _vtK| ceᶒwbaᶒi Z GB gvbtk tK>" Kti
ukᶒvμg ev`bvqb c`tᶒc tbi qv nq|
- **ZjwšZ gᶒ tKŠkj (Enhanced Open Technique):** ukᶒvi RvZxq gvb m"utKᶒ
mg`K AeinZ nq Avil mᶒthvvi Z `i`wó wbtq G tKŠkj KvR jvMvbtv nq|
mgvRi tfr³vt`i D"pivᶒv, cöqvRb Ges cöZthvMZvgj-K RMtzi Avkv-
Avkvᶒv tgUvbtv Rb" G aitbi tKŠkj MhY Kiv nq| D`vniY`tfc aiv hvq
weMZ wekᶒvcx KivúDvvi tcvMᶒgs cöZthvMZvq evsj vt`k 1998 mtj BDti vtci
f`vuj`bv, 2000 mtj w`j tZ Ges 2001 mtj tdvii Wvq AZ"šl Drmvne`AK
djvdj Kti Dbz wekᶒi `wó AvKIᶒ Ktitq| dtj ejv Pj t`tki KivúDvvi
ukᶒvi ÷`vUvWᶒAZ"šl Dbz bv ntj I Gtᶒtᶒ tgavext`i Rb" KivúDvvi ukᶒvi
ZjwšZ tKŠktj i gva`tg AMᶒvgx (advanced) ukᶒvμg I civ"mip cᶒqb Kti
tgavex mgvRtK AMᶒvzi w`tK GvMtg hvevi mᶒhvm t`lqv miKvi I t`kevmxi
`vqZj|
- **mKtj i cöqvRb tglvevi h_v`ᶒKŠkj (Basic Niche Technique):** meᶒvavi tYi
DcthvMx tKŠkj MhY Kti cöZövb hv` th tKvb GKw wel`tg wekᶒl gtvthvM w`tg
cöZövtbi cöZ Rbmavi tYi `wó AvKIᶒ KivtZ mᶒᶒg nq Zvntj Avt`l Avt`l H
cöZövb mKj wel`tg DrKIᶒmvaib civ`g nq Dtv| D`vniY`tfc ejv Pj AtbK
tᶒtᶒ t`Lv hvq tKvb ukᶒv cöZövtbi tKvb mᶒvg bvB, atK atK Pj tᶒ| H tᶒtᶒ
nVv GKRb Bbv`wDUU cövb tLj vajvi w`tK wekᶒl bRi w`tg 2/3 eQtii gta"
_vbn ev tRjvq wμov cöZthvMZvq ukᶒv_xp i w`tg ht`ó fij djvdj ARᶒ
KtZ cvi tjb| H cöZövb G Hvzn" eRvq titL cieZxᶒZ tj Licovq fij Kivi
cöZ wekᶒl ᶒiazᶒti vtci gva`tg 8/10 eQtii gta" GjvKvi AZ"šl fij cöZövtb
cwiYZ ntZ cvti| G tKŠktj mKj aitbi ukᶒv_xfv DcKZ.nq|
- **ZjwšZ h_v`ᶒKŠkj (Enhanced Niche Technique):** Gtᶒtᶒ ukᶒv cöZövtK
wekᶒl tᶒtᶒ Av`kᶒvbxq nevi Dti`tk" wekᶒl wKQytKŠkj cöqvm KtZ nq| Zvi
dtj Lᶒ ZvovZvno cöZövtbi migvRK mᶒvg Avtm Ges gvb Dbqtb tKŠkj ati
ivLtZ cvi tjb Gme cöZövb μgvMZ Dbz i ukLti Dtv| G aitbi D`vniY
Avgt`i mgvRb cᶒz itqtq| cöZvU kni tek wKQywe`vj q, Ktj R itqtq

th,tj vřZ ıKŃv_xŃv fıj dj vdj ARŃ Kti etj G mg`ı cŃZŃvb AvRřK AZ`řı fıj gvb ARŃ Kti řQ| ıKŃvi gvb Dbqřb ZjııřZ řKřkj AZ`řı Kıvřıx| 1888 mıj ř_řK 1920 mıj chřı fıv ZeřıBřıRıv Zıř`ı ıbR`^Kıv`vq ZrKıvxb cŃZ řRj vřZ GKıW Kti mı Kwı nıv Břıj k`ř`ıcb Kti ıKŃvi ,YMZ gvb ıWK tiřL ıKŃv e`e`vi cŃj b KtiıQj | H`ř`ı,tj vi AbıııřY mıv Dcgıvř`řk nıv Břıj k`ř`ı Mřo DřVıQj Ges H mKj cŃZŃvbı ıKŃvi gvb GZB Dbř ıQj th Gř`řki řQj řgtıv BDřıv, Avřıı Kıv řj Lıvov Kti ıbřřı`ı mgŃZıŃZ KıřZ řKıv Kó ev řem řcřZ nq ıb| Zıv cŃvb KıvY ıgıvMZ gvb Dbqřb Ges Aıřř gřıbı mıgıřı Lv ıbqřıY|



cvřVřı gj`ıqb 1.2

A) eú ıbeřbř cřæ

mıWK Dřı ıbř`Rgj-K AŃııWřK eřııqZ Kıab| (D`vııY: Aıvbrı ıbeřřZ DřııW K nřj GřK eřııqZ Kıab)

- 1| Dbř ř`řki bıMıı Kıv cŃqııWK ıKŃıvq Dbř řKb?
 - (K) Dbř ıKŃıvq mKřj B Drmıvıx ıeavq
 - (L) ıKŃKıv cŃqııWK ıKŃıv ıe`řı Zrcı ıeavq
 - (M) ıKŃıv cřıvıKıv Dbř ıPřıřıvıvı AııKıvıx etj
 - (N) `ıZı-MřıxZıv mKřj B RıeıvřıřK ıKŃıvřK cŃıvı` ř`q
- 2| ıKŃıv cŃZŃvb Av`k`ıbıxq ıKfıře nřZ cıřı?
 - (K) cŃZŃvb cŃıvıbı ıeřkl řKřkj cŃqıřMı gıvřg
 - (L) cŃZŃvb Dbqřbı Rb`cřı Aıı`R mıvqZıvı gıvřg
 - (M) Dbř ř`k ř_řK fıj cřıvıK ıbhıř Kti
 - (N) mıvııY cřıvıbı Aıvřkj` Aı`vq Kti
- 3| ZjııřZ gıř řKřkj řKb MřıY Kıv nq?
 - (K) `řZ Dbř ř`řki mgKŃ neıvı Rb`
 - (L) ř`řki ıeřkl Pııı`v cıřıYı Rb`
 - (M) řıv`ıř`ı cŃZřııMZıvıj-K Pııı`v řgıvıvı Rb`
 - (N) ıKŃıv_xŃ AıřřıvıKř`ı Dbř ř`k m`úřK`arı Yı ř`ı qıvı Rb`

Av) mıřřB Dřı cřæ

1. ııřZı ı`K ř_řK MZıvııZK | Dbř ıKŃıve`ıcbı ıcıııgřıWı cı`ř` ıK?
2. ıKŃıvřřıř`ı`ıZıv | MřıxZıv Kıvıv?
3. ıKŃıv_xŃ AıřřıvıKř`ı KıvQ ř_řK ıK aıřbı ıPřıřıvıvıvı Aıřıv?

B) ıPıvıj-K cřæ

1. ıKŃıvı gvb Dbqřbı eW řemW řKřkj AvřıvPıv Kıab|
2. ZjııřZ gıř řKřkj ıK? G řKřkj ıKfıře AıvıbK ıKŃıv ıe`řı mıvıvı` KıřQ?

mıWK Dřı : A) 1| N 2| K 3| M|

cW 1.3

ጠቅላይ ገዢዎች ለድህረ ገጽ ፍጥነት

[Total Quality Management of Education]

ገጽ

GB cW ተቀባይ ለሰጠው –

- ጠቅላይ ገዢዎች ለድህረ ገጽ ፍጥነት ለማሳካት ማቅረብ ይገባል፤
- ጠቅላይ ገዢዎች ለድህረ ገጽ ፍጥነት ለማሳካት ለሌሎች ገዢዎች ጋር ማቆራረጥ ይገባል፤
- ጠቅላይ ገዢዎች ለድህረ ገጽ ፍጥነት ለማሳካት ለሌሎች ገዢዎች ጋር ማቆራረጥ ይገባል፤

ጠቅላይ ገዢዎች ለድህረ ገጽ ፍጥነት ለማሳካት ለሌሎች ገዢዎች ጋር ማቆራረጥ ይገባል፤ ጠቅላይ ገዢዎች ለድህረ ገጽ ፍጥነት ለማሳካት ለሌሎች ገዢዎች ጋር ማቆራረጥ ይገባል፤ ጠቅላይ ገዢዎች ለድህረ ገጽ ፍጥነት ለማሳካት ለሌሎች ገዢዎች ጋር ማቆራረጥ ይገባል፤ ጠቅላይ ገዢዎች ለድህረ ገጽ ፍጥነት ለማሳካት ለሌሎች ገዢዎች ጋር ማቆራረጥ ይገባል፤

“Vision without action is merely a dream. Action without vision just passes the time. Vision with action can change the world.” Barker (1990)

GKRb ተቀባይ ለሰጠው ለድህረ ገጽ ፍጥነት ለማሳካት ለሌሎች ገዢዎች ጋር ማቆራረጥ ይገባል፤ ጠቅላይ ገዢዎች ለድህረ ገጽ ፍጥነት ለማሳካት ለሌሎች ገዢዎች ጋር ማቆራረጥ ይገባል፤ ጠቅላይ ገዢዎች ለድህረ ገጽ ፍጥነት ለማሳካት ለሌሎች ገዢዎች ጋር ማቆራረጥ ይገባል፤ ጠቅላይ ገዢዎች ለድህረ ገጽ ፍጥነት ለማሳካት ለሌሎች ገዢዎች ጋር ማቆራረጥ ይገባል፤

ለድህረ ገጽ ፍጥነት ለማሳካት ለሌሎች ገዢዎች ጋር ማቆራረጥ ይገባል፤ ጠቅላይ ገዢዎች ለድህረ ገጽ ፍጥነት ለማሳካት ለሌሎች ገዢዎች ጋር ማቆራረጥ ይገባል፤ ጠቅላይ ገዢዎች ለድህረ ገጽ ፍጥነት ለማሳካት ለሌሎች ገዢዎች ጋር ማቆራረጥ ይገባል፤ ጠቅላይ ገዢዎች ለድህረ ገጽ ፍጥነት ለማሳካት ለሌሎች ገዢዎች ጋር ማቆራረጥ ይገባል፤

- ጠቅላይ ገዢዎች ለድህረ ገጽ ፍጥነት ለማሳካት ለሌሎች ገዢዎች ጋር ማቆራረጥ ይገባል፤
- ጠቅላይ ገዢዎች ለድህረ ገጽ ፍጥነት ለማሳካት ለሌሎች ገዢዎች ጋር ማቆራረጥ ይገባል፤

- cÅZõmbK mKj KvfR ʲti gZvgZ cÅZdj Z nI qv|
- cÅZʃhVMZvgj-K j ʲi mʲútkʲmʲPZb nI qv|
- cwigvc I djveZʒ cÅquv eˆenvi Kʲi c×wZMZfvte cÅZõvbi ʲwBK mʲe ʲvcbv wõwZ Kiv|

tKvb cÅZõvb cwi Pvj bvi gvaʲtg ɛkʲvi gvb wõwZ Kivi Rb ʲi ayDcvc, ʲjv Rivb
_vKʲj B gvb wõwZ nq bv| mgvʲR eú cÅZõvb AvʲQ th, ʲjv mg ʲAvBb Kvbly tgʲb
Pʲj I mvdj ʲ ʲʲLw| ZvB wK wK KviʲY cÅZõvb AKZKvʲnq Zv Rivv Avek ʲK|
Kvi Y, ʲjv wbgʲfc:

- cÅZõvb mʲútkʲ ʲ ʲwóʲZ mKʲti mgvb mZKʲv bv ʲvKv| wʲvfbʲeRb wʲvfbʲe
ʲwóʲKviY ʲ_ʲK ʲʲLv| ci ʲúʲii gʲa ʲ ʲwó Ges mʲʲʲni Rbʲ nʲj mʲúʲ³
ʲjvKej mʲvʲj Zfvte KivR KiʲZ cʲvi bv|
- MõxZvʲi ʲ_ʲ ʲw ʲʲK bv ZvʲKʲq wʲʲʲi Avw ʲ cÅZõvi w ʲʲK ʲwó wbeÜb|
- memgq ɛm×vʲš Pwʲʲq ʲ ʲI qv Ges Top-down ev DʲʲʲʲZ wʲPzcKwʲʲZ Pj v|
ɛm×vʲšMõʲY KgrZʲ mKj mgq cʲve Lvʲv Ges wʲʲʲi ɛm×vʲšAuj ʲvKv| Gi
dʲj ci ʲúʲii ɛekʲm Kʲg hvq Ges cÅZõmbK ʲ ʲ Mʲto Dʲv bv|
- Aa ʲbʲi Kivʲi ʲʲw. bv ʲ ʲI qv| fvj Kivʲi Rb ʲ wʲʲʲ cʲsmv tʲl qv Ges gʲ
Kivʲi Rb ʲ Ab ʲ ʲ ʲvqx Kiv|
- Aa ʲbʲi cʲj ʲZ. I wʲzi ʲZ. Kivi tʲʲʲ cʲwʲʲZ; cÅZõvbi ʲj MZ ʲúʲv bó
Kʲi ʲq|
- Aa ʲbiv Aciva Kiʲj wʲʲʲʲ tʲʲK kvmb bv Kʲi mʲvʲmʲL AcgvmbZ Kiv nʲj
Zvʲi gʲa cÅZõvb, KgRZʲ Ges cÅZõvbi cÅZ ɛmʲvʲʲK I ɛeʲI cʲvcy
gʲbvʲve Mʲto Dʲv hv cÅZõvbi Agʲj tʲʲK Avʲb|
- AvʲʲAnʲvix I Dʲʲʲʲv ʲI qv Ges hv bq Zv cʲvi Kiv| Gme GKmgq Rb
mʲvʲL DʲʲwZ nʲq hvq Ges cÅZõvʲK ʲwʲMʲ Kʲi |
- wʲʲʲi mʲúʲKʲAvZ cʲvi KvhʲgʲʲK AʲbK mgq RbMY ʲʲv gʲb Kʲi |
- eú Kivʲi ʲwqʲ; cʲv wʲKʲʲZvi mʲʲ_ mʲʲ_ Aw ʲ mʲvʲ I ʲʲgZv bv ʲ ʲI qv|
- KZʲʲʲi ʲʲv mʲúʲKʲmʲgʲj vPbv Kiv, Kvi Y Abjwv bv Kʲi tʲʲm hvʲI qv Ges
mgʲʲvʲPKʲi ʲʲwzi wʲšʲ Kiv|
- GKw cÅZõvbi mKj ʲK wʲʲʲ GKw cwi evi MVb Kʲi tʲl qvi mvg ʲwʲv|
- KgRZʲ, Kgʲvixʲi avivmʲK gʲʲvqʲbi eˆe ʲv bv ʲvKv| Kivʲi ʲʲv ʲvKʲj
Zv kbv³ Kʲi mʲʲkvʲbi mʲhvm bv w ʲq kw ʲi wʲavb Kiv|

mʲ ʲ eˆe ʲvcbvq ms ʲwZ, cÅZkõZ I thMʲthM

ɛkʲv cÅZõvbi mʲ ʲ eˆe ʲvcbvq 3C AZ ʲš ʲi ʲzʲʲ G, ʲjv nj - Culture, Commitment Ges Communication ev ms ʲwZ, cÅZkõZ Ges thMʲthM| ms ʲwZi
DciB mʲʲv cÅZwZ| hLbB ɛkʲvi gvb Dbqʲbi cʲkʲeAvʲm ZLbB ms ʲwZi K_v
Gʲm hvq| ms ʲwZʲK ev ʲ w ʲq Dbqʲb mʲe bq| ZvB wʲR ms ʲwZ. Rivv Ges ms ʲwZi
cÅZ mʲvʲʲv ʲvKv Avek ʲK| H cÅZõvb mdj nʲe th cÅZõvbi ms ʲwZʲZ -
1. mRbkj ZvʲK DʲP gʲ ʲ ʲI qv nq;

ms ʲwZ.

mWK DEi : A) 1| N 2| K 3| N|

cW 1.4

ukŷvi gvb Dbqtb c`tŷc

[Steps for Development of Quality of Education]

Dŷik`

GB cW tkŷl Avcb –

□ ukŷvi gvb Dbqtb mrvh`Kvix c`tŷc, tŷvi bvg Dŷl KiŷZ cviŷeb|

gvbm`ubae`e`vcbvB ukŷvi gvb Dbqtb mŷg| bquW c`tŷtci gva`tg ukŷvi gvb Dbqtb cŷquv mnR, mvejxj I `ZÜZŷŷe Pŷj | GB cŷquv, tŷv avivewnKfŷe Avŷj vPbv Kiv nj |

mm`všMŷ

bvuz ev`evqŷbi Rb` tmvcvbwfŷE K c`tŷc MŷY KiŷZ nq| c`tŷc MŷY mgm`v Avmŷe, H, tŷvi mgvavbKŷi AŷbK, tŷv weKŷi cŷŷe t`ŷK DEg weKŷiW tetQ wbtq mgvavb w`ŷZ nŷe| GBfŷe wPšŷfvebv I hŷŷi gva`tg mKŷj i Kj `vŷt`DEg weKŷiW MŷY KivB mm`vš| mm`vš GKKfŷe A`ev MYZwšK c`wZŷZ nŷZ cvŷi | mm`vš MŷYKvixi wR`^MŷŷZ thvM`Zv `vKŷZ nŷe Ges ZŷK Dchŷ Avŷbi AvwKvix nŷZ nŷe| ZŷK wbiŷcŷ Ges mr nŷZ nŷe| wZwb m`vPvi Y I wefŷbŷgŷvweK , ŷYi AvwKvix nŷeb| wZwb Dŷ`vMx nŷeb Ges wŷR Drmrvx nŷq KvR Kŷeb| wZwb Aek`B Aa`bŷi cŷkŷY w`ŷZ mŷg| Eaŷŷb I Aa`bŷi Av`v ARŷbi thvM`Zv Zui `vKŷe| wZwb wŷRi Review`wZvi cŷZ mRvM I mcŷZf nŷeb|

GUv Avguŷ`i mŷbw`ŷfŷe Rvbn DŷPZ th ukŷvŷ sariŷk man unŷyan byabŷhpana sangŷiŷŷ wŷtar` welq, tŷvi Dci wŷfŷ Kŷi |

- `ŷ`ŷ (vision)
- wefŷbŷKvŷRi Rb` MŷYŷhvM` tKšKj (strategy)
- KŷvŷZ jŷŷŷ` tŷŷvi Rb` Mfŷi AbŷŷZ (outrageous goals)
- mŷg I mŷi GKwŷ `j (a harmonious team)
- ``bw`b KvR e`e`vcvri Kŷhŷix cŷquv (tools for daily management)

gvbm`ubaKvŷRi Rb` cŷZÁv

ukŷvi gvb Dbqtb me`ŷi gvb m`ubaKvŷRi weKŷi tbB| cŷwŷK `ŷi t`ŷK D`PZi `ŷi chŷŷh w` tKv`vŷ gŷŷbi NvUwZ `ŷK Zvntŷ Zv mKj `ŷiŷK `ŷŷ Kŷi t`ŷe| ukŷvi `ŷKZ.gŷŷbi Rb` memgq mŷPó `vKŷZ nŷe|

gvbm`ubakŷŷK I Kgŷŷbeŷb

GK mgq wŷj me`ŷi i ukŷv wefŷŷmi tŷvK wŷqŷŷY GKwŷ weŷKl gŷŷK ghŷv t` I qv nŷZv| wKš` AvwK msL`K AvZwi` ukŷv cŷZŷv `vcB Ges wKŷŷmsL`K cŷjvcŷj tckwŷŷE K ukŷv tŷŷŷg`vŷKvix cŷZŷv Mŷo DVvq thvM`Zi ukŷŷK Ges DEg e`e`vcK ukŷvŷŷb w`b w`b Kŷg hvŷ`Q| wKš`ukŷvi gvb Dbqtb Ges eZŷŷv gvb aŷi i vLvi Rb` thvM` Rbm`ú` wbeŷb Ges wŷtqvM t` I qv gj- cŷquŷŷK Zj wšZ Kiŷe|

Av`k@baŃY

Avgiv ᄡK PVB, ᄡKfŃte PVB Zv cŃtgB ŃbaŃY KŃi gvb Dbq̃b cŃkæAvmtZ nte| gvb Gi cŃkæAvmtjB Avgiv ᄡK AvgvŃ`i ŃbŃRŃ`i gŃWŃj Avmt̃v bv Ab` tKvb gŃWj AbŃiY KiŃv Zv ŃbŃq ᄡPŠŃ fŃṽvi gva`tg Av`k@baŃY KiŃZ nte|

Pwn`v ŃbaŃY

AvgvŃ`i Pwn`v ᄡK? Avgiv tKvb ᄡŃi thŃZ PVB? CŃáZ Pwn`v AvŃMB ŃbaŃY KŃi AMŃi nŃZ nte| Pwn`v ŃbaŃY eü DcŃq nŃZ cvŃi, thgb- bgŃv Rwi c, MY`gvb` tjvKŃ`i mŃ_ AvŃj vPbv, cŃZŃekx t`Ńki ᄡKŃvi gvŃbi chŃeŃY I chŃj vPbv, Dbz t`Ńki ᄡKŃvi MŃZaviv jŃ` Kiv BZ`Ń |

Pwn`v ciŃYi DcŃhMx e`q eivŃ

Pwn`v hZB ŃbŃcY Kiv tnvK bv tKb cwiKŃbv AbŃvqx Kg@xŃZ ev`ŃvqŃbi e`q ŃbeŃni DcŃhMx A_`eivŃ _vKŃZ nte| e`q mŃKfŃte KiŃZ nte Ges Zvi Rb` mŃyúo Reven`ŃZvi e`e`v KiŃZ nte|

Pwn`v ciŃYi Rb` cŠŃ kvŃKŃY

tKvb DcŃq AeŃ ŃŃb Pwn`v ci-Y mæe Zv ceŃŃyB kvŃ³ KŃi KŃR i iæKiŃZ nte|

cŃZŃvbK iŃ

cŃZ`K KvŃRi Rb`B cŃZŃvb cŃqvRb| ᄡKŃvi mŃvĚ gvb DbqŃbi Rb` cŃZŃvb MŃo ZŃŃZ nte|

Dbq̃b I gvb Dbq̃b Ae`vb ivLvi cŃŃqv PŃjŃq thŃZ nte

AvgvŃ`i t`Ńk mŃyi mŃyi cŃKŃ MŃY Kiv nq| ᄡKŠ` GŃ`i GcŃBmvj ŃŃcvŃUP Dci ŃŃŃĚ KŃi dŃj vAv cŃŃŃg Kiv nq bv| cŃKŃ mgq cvi nŃq tMŃj mvdj` DĚŃivĚi eŃx i Rb` G cŃKŃŃi mvdŃj`i Dci ŃbŃŃ KŃi cieZŃcŃKŃ MŃY Kiv cŃqvRb, ᄡKŠ` Zv tgŃŃUB Kiv nq bv| Zvi GKŃU t`kxq D`ŃniY nj gva`ŃgK ŃeÁvb Dbq̃b cŃKŃ | GKŃU PgrKvi mŃ_Ě cŃKŃ nŃqv mŃĚj cŃKŃ ev`ŃvqŃbi cŃi Avi ᄡKQŃ aŃi ivLv nqvb| dŃj DĚg djvdj I tKvb KvŃR jvŃMŃb|

D

D Øviv Delegation tevSvq| tKvb gvbyB GKv mKj KvR KitZ cvti bv| cØZØvbK KvR mvdŕj`i mŕt_ mæúbæKivi Rb` thvM`Zv Abyvŕti mKŕj i gŕa` ¶lgZv fvM Kŕi w`ŕZ nq| `wqZ; Aŕb`i Dci Avŕivc Kŕi cvi ex¶Y Kitj Kg©mæúv`b fvj nq| KvŕRi gv b evto|

E

E Øviv Encourage Kiv tevSŕbv nq| tKvb KvRB mnKgxŕ i wbiarmvŕZ Kŕi mæúbe Kiv mæe bq| ZvB mnKgxŕ i DrmŕvŕZ KŕiB , YMZ gv b ARØ Kiv mæe| KvŕR DrmŕvŕZ Kiv Ges fvj KvŕRi Rb` cy`Z.Kitj mnKgxŕ i gvbmK kv³ ewx cvq| dtj Zviv RŕwJ KvR KitZ wQcv nq bv| kvŕvvi K kv³ i gŕbvej AŕbK eo| ZvB GKRB mdj tbZv tcØYv I Drmŕvŕni gva`ŕg KvR Kwiŕŕg wŕŕg _vŕKb| Gi dtj mŕvveŕfvŕte KvŕRi gv b ewx cvq|

R

R Øviv Recognition tevSvb nq| cv exŕZ mKj gvbyB Recognition Pŕvq| th tQvU wki gvŕ Avŕav Avŕav K_v ejŕZ wLŕØ, ZvŕK Zvi K_v ejvi `ŕKwZ. w`ŕj tm Avŕiv tevK K_v ejvi Drmŕvŕ cvq| wK tZgvbŕvŕte mKj chŕŕqi Kgxŕ i Zvŕ`i KvŕRi `ŕKwZ. w`ŕj cieZxŕZ Zviv Avŕiv fvj fvŕte KvR Kitē| fvj tbZv memgqB Zvi Kgxŕ i `ŕKwZ. w`ŕŕg DrmŕvŕZ Kŕi _vŕKb| ZvŕZ KvŕRi MŕvZ mÅvŕi Z nq Ges gv b evto|

tbZŕZj wKvk

tbZŕZj wKvk: mgvRb etj _vŕKb Leaders are born not made| wKŠ` eZØvb hŕMi tbZviv Zv etj b bv| `p cŕZ`q wŕŕg cik¶Y Ges Av`kŕbZvŕ`i mŕt_ DVvemv Ges wq_w`ŕvi (Interaction) gva`ŕg tbZv `Zvi Kiv hvq| gvby mŕgvwRK Rŕē| mgvR Dbæb Kiv gvbyŕ i KvR| mgvR Dbæbŕi Rb` gvbyŕK cŕg gvby nŕZ nq| GB gvby nevi Rb` wZvqvZv I wK¶ŕŕKi tbZŕZj cØqvRb| Zvŕ`i tbZZ; fvŕel`r Rŕæŕbi c_ŕ`Lvq| gvZvncZv I wK¶ŕŕKi wŕŕ`KZ c_ Abyvi Y Kŕi KŕVvi mŕavv I kŕgi gva`ŕg GKŕ b H wK¶ŕv cØZØvŕbi wki/wKŕkvi/hŕgK ewj ø tbZvq cvi YZ nq| ZvB gvbwK , Yvevj i wKvŕŕki Rb` tbZvŕK tbZŕZj chŕŕq thŕZ hŕ_ó mgq e`q KitZ nq I m`v mŕPó _vKŕZ nq| ŕŕg ŕŕg tbZŕZj wKvk NŕU| wKvkZ tbZvB GKŕ b tbZZ; w`ŕŕg cØZØvŕbi Dbæb Kŕi wK¶ŕv_xŕ i wKvk NUŕZ mŕvŕh` Kŕib| Avi Gi gva`ŕg wK¶ŕvi gv b Dbæb NŕU|

wK¶ŕv cØZØvŕbi tbZvi tbZZ;wK¶ŕvi gv b Dbæbŕ KZUKzmnŕvqZv KiŕØ Zv hvPvB Kiv Aek`B cØqvRb| tbZv nŕjB gv b Dbæbŕ `ŕŕi ivLŕeb Ggb K_v tbB| tbZv Zvi AvŕfÁZv I wK¶ŕvi gva`ŕg KZUKzMŕY KitZ tçŕiŕØb, GB MŕhYKZ. AvŕfÁZv KZUKz avi Y Kŕi ev`ē tŕŕŕŕ cØqvM KitZ tçŕiŕØb Zvi wPŕiB tbZvi Ae`vb cŕKvK Kitē|



cvVĚi gj`vqb 1.5

A) eú ubePbx cĕæ

mĭWK DĚi ũbĕ` Rgj-K Aŕji ũĭĭK eĚvĭqZ Kiab| (D`vniY: Aŕcbvi ũbePZ DĚi ũW K ntĭj GĭK **(K)** eĚvĭqZ Kiab)

- 1| ŐLeadership has to be caught ŐGi A_ŕK ?
 - (K) AZxZ KvĭhP ũŕiĚĭZ tbZv ũbePb Kiv
 - (L) hk`ŕ e`ŕĭĭĭK tbZv ũbePb Kiv
 - (M) eskMĭZ ĩ`ĭL tbZv ũbePb Kiv
 - (N) Ávb I`ŕĭZv ARĭbi ũŕiĚĭZ tbZv ũbePb Kiv

- 2| DĚg tbZvi ũY ĩKvĭũ?
 - (K) AĭK_vq cĕŕvĭŕĭZ Kiĕb teĭk
 - (L) PUK`vi K_vq mĕm`v mĕvavb Kiv
 - (M) cĕŕve Lmĭĭq mĕm`v mĕvavĭbi ĩPŕv Kiv
 - (N) mKjĭK Lĭk Kĭi mĕm`vi mĕvavb Kiv

Av) mŕŕĭB DĚi cĕæ

- 1. DĚg tbZvi cĕŕvb ũY, ĩjv ũK ?
- 2. Reŕvĭ ũnZv ej ĩZ ũK teŕŕvq ?
- 3. `ŕKĭZ.i cĕŕvRbĭqZv ũK ?

B) ĩPbĭgj-K cĕæ

- 1. LEADER kĭāi gĭa` tbZĭZi ũYreŕj ũKŕĭĕ ũbŕnZ AvĭQ? e`vL`v Kiab|

mĭWK DĚi:

- A) 1| N 2| K|

t`tk mgq mgq gj`vqb Ges mvgwMk gj`vqbi gva`tg th dj`veZB (feed back)
civl qv hviq Zv we`tkd`Y Kti uk`v_x`Kw`K uk`vivi mvgwMk gj`vqb m`e|

Dbqab cšv`ibaŋY: mvgwMk gj`vqbi Dci wbfP Kti Avtiv Dbqabi cšv` AbyvÜvb
Kiv cŋqvRb| Zvi Rb` cŋqvRb avivewnk KvhRix MtelYv|



civ`VvEi gj`vqb 1.6

A) eü`ibePbx cŋæ

mivK DEi wbt` Rgj-K Aŋi wtk eŋvqZ Kiab| (D`vniY: Avcbvi wbePZ DEi wK
ntj GtK (K) eŋvqZ Kiab)

- 1| uk`v_x`Kw`K Kvhŋ`úv`b wK ?
 - (K) uk`v_x`etePbi gj`ielq
 - (L) uk`v_x`v meiwKQyKite
 - (M) uk`v_x` i w`tg meiwKQyKwi`tg wbtZ nq
 - (N) uk`v_x`me KvR uk`v`KtK mivv` Kti

- 2| uk`v_x`Klb Zvi civ`V AvMhx nq ?
 - (K) gvZv wczvi Zx² `wó`_vKtj
 - (L) civ`Vi welqe`R`xeww`f`EK ntj
 - (M) civ`MhxY Zvi Pwv`v ci`Yi m`tebv`_vKtj
 - (N) uk`v`K uk`v_x` tLwR Lei wbtj

Av) msuŋB DEi cŋæ

- 1. uk`v_x` i tj Lvcovi cwí Kíbv wKfite Ki`Z nq ?
- 2. Avgt` i t`tk uk`v_x`v Zv` i cŋYZv hivvB Ki`Z civti bv tKb ?
- 3. cwí exŋY I ZE`yavtbi cŋqvRbxqZv wK ?

B) iPbvgj-K cŋæ

- 1. uk`v_x`Kw`K Kvhŋ`úv`b wK eyStq wj Lly|

mivK DEi :

A) 1| K 2| M|

e`e`v Avek`K| Zte GB e`e`v e` ubitcŋ nŷZ nte| Awdm cãvbtK G e`vcvŷi
mRvM`wó w`ŷZ nte| Zv br ntj hv`i cŷ`Z.nevi K_v ZrivB wZi`Z.nŷe| G mKj
NUbv TQM tK evawM`Kti |

cãkŋY I Dbq̄b

cãkŋY I Dbq̄b I ŷZvŷcãZfvŷe RwoZ| GKUŷK Qvov Ab`uU AMñi nq br|
hŷMvcthvMx cŷ:cãkŋY GKRb wKŋKŷK KvhRix cv`vŷb mrvv` Kti, Avi welqe`i
Ávb H tŋŷŷ KvhRvvi Zvi wfwE`Zwi Kti| ZvB GKRb fij wKŋKŷK me mgqB Zvi
welqe`ŷZ cvKv nŷZ nte, Zvici cãkŋŷYi gva`ŷg IB ÁvbtK wKŋv_xŷi gŷa`
mÁvjŷbi e`e`v Kivi meŷx̄b cãPóv KiŷZ nte| wKŋv jvŷfi cã_wgK e`e`v I
cãkŋŷYi gvb mweR wKŋvi gvb Dbq̄b Dchŷ wKbv Zv MŷelYvi gva`ŷg hvPvB Kti
AcŷZv_vKŷj cŷ`Kivi e`e`v KiŷZ nte, Avi cŷZv Avmŷj Avŷiv Dbz̄ Kivi tPóv
KiŷZ nte|

máúK`icb

gvb Dbq̄bŷi Rb` wKŋv cãZóvŷbi wKŋKMY Ges`ŷ, Kŷj R, nekpe`ij ŷqi m`ú³Zv
Lŷ teik cãqvRb| mKŷj hv` wŷj wŷk Ávb PPPKŷib Ges cãZ`ŷKi mŷ` cãZ`ŷKi
fij máúK`vŷK Zv ntj meŷŷŷŷ Dbq̄b m`e| cãZóvbKfvŷe mKŷj i gŷa` msnwZ I
tmsn`_vKŷj wŷRŷ`i gŷa` HK` I fij evmŷ Mŷo DŷV Ges Zv wKŋv_xŷi i gŷa`
mswŷgZ nq I gvb Dbq̄b mrvv` Kti |

mvsMvbK máúK`

wKŋK, KgPvix, KgRZŷ`i gŷa` mvsMvbK máúK`Mŷo DVŷj mKŷj i gŷa` GKUv
BwZevPK`wófwz Mŷo DŷV hv` cãZóvbK KvŷRi Lŷ mrvqK nq Ges wKŋvi gvb
Dbq̄b , iazcŷ`FwgKv cvj b Kti |

Kvhŋŷŷi cwiŷek

mKj KvŷRi Rb`B fij cwiŷek cãqvRb| fij cwiŷek Dbz̄ gvŷbi KvR t`q| AZGe
wKŋv_xŷi wKŋK, KgRZŷ`mKŷj i B KvŷRi cwiŷek KvŷRcthvMx nŷZ nte|

**ŷ`ŷ, Kj`vY I
wivcE`v**

G_s ŷjv gvŷŷi i tgŷŷj K Pwv`v| G_s ŷjv cŷŷYi e`e`v meŷ`_vKv evÁbxq|

**mgvŷRi mŷ`
thvMŷhvM**

wKŋv cãZóvb mgvŷRi A½| mgvŷRi Kj`vYv`_cãZóvb| Avi cãZóvŷbi Kj`vY
mgvRB Kti _vŷK| G`wó ci`úi wŷfŷkŷj | wKŋvi e`e`vcbr mgvŷRi Pwv`v
tgUvŷvri Rb`| wKŋv mgvŷRi Pwv`v tgUvŷ`Q wKbv Zv hvPvB Kti KvhRvvi Zv wŷifcY
Kiv cãqvRb|

**Af`šŷiY
thvMŷhvM**

cãZóvbK mvdj` Af`šŷiY mgzthvMŷhvŷMi Dci wŷfŷkŷj | thvMŷhvM wK bv ntj
fŷ`ãwšŷi m`ŷebr AŷbK teik _vŷK| dŷj fŷ`eŷvenŷi mŷó nq| cãZóvŷbi gvb
wŷgŷvŷ nq, wKŋv_xŷi nZiv nq| mveŷŷwYK cwiexŋY I gvŷUwŷs-Gi gva`ŷg GB
thvMŷhvM KvhRix i vLŷZ nte|

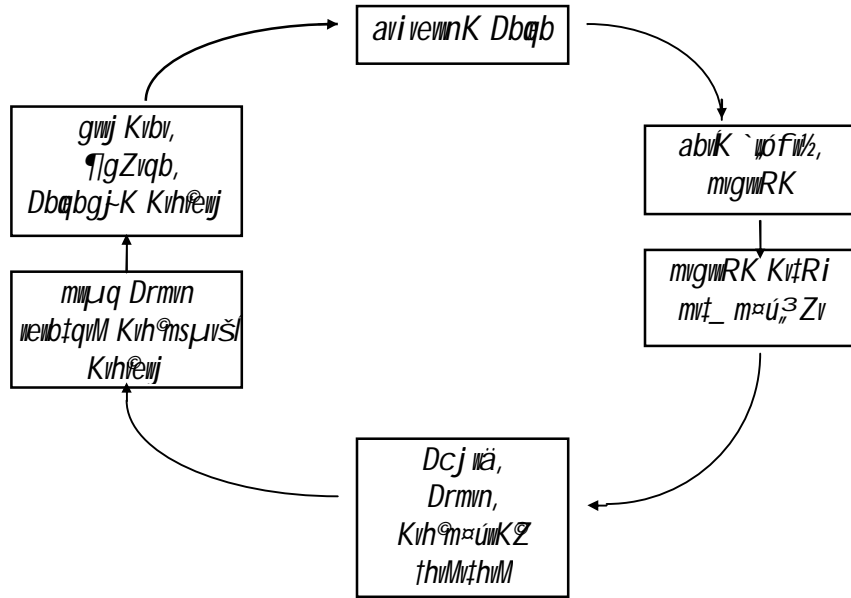

ᄡᄡ 1.7-1 : mvgvRK gvb=úbansMᄡbi Dbqb



cvᄡVvEi gjᄡvqb 1.7

A) eü vbeᄡbx cᄡæ

mᄡK DĒi ᄡbᄡ ᄡgj-K AᄡiᄡᄡK eᄡvᄡqZ Kiab | (D`vniY: Avcbvi vbeᄡPZ DĒiᄡ K ntj GᄡK ⊗ eᄡvᄡqZ Kiab)

- 1| temiKvii Kgᄡᄡj Kgᄡvixᄡ`i gᄡa` nZvkvii mᄡᄡ nq tKb ?
 - (K) Eaᄡᄡb KgᄡZᄡv Aa`bᄡ`i mᄡ_ Abᄡvq AvPi Y Kᄡi
 - (L) Eaᄡᄡb KgᄡZᄡv Aa`bᄡ`i Amvᄡq Aeᄡvq ivᄡL
 - (M) teZb Kvᄡᄡgvi eo aiᄡbi `elg`
 - (N) Aa`bᄡ`i cᄡZ Eaᄡᄡbᄡ`i Nᄡvi gᄡbvᄡve
- 2| KvᄡRi ᄡᄡKᄡZi cᄡᄡqvRbxqZv ᄡK ?
 - (K) gvbᄡᄡi gvbᄡeK eᄡᄡ_ᄡj v ᄡeKvᄡk mᄡvᄡh` Kᄡi
 - (L) gvbᄡᄡK mᄡvᄡx ᄡᄡgKv cij b KiᄡZ DrmᄡvZ Kᄡi
 - (M) Eaᄡᄡb I Aa`bᄡ`i m=úᄡKᄡ Dbqb NᄡU
 - (N) cᄡZöᄡᄡbi Kvhewj mᄡi ᄡvᄡe KiᄡZ mKᄡj DrmᄡvZ nq

Av) mᄡᄡᄡB DĒi cᄡæ

1. cᄡ_vi ᄡK ᄡvᄡe mvgvRK gvb Dbqᄡb mᄡvᄡh` Kᄡi ?
2. thvMthvM ᄡK ᄡvᄡe mgᄡᄡcᄡᄡvᄡ nᄡZ cvᄡi ?
3. Kgᄡᄡᄡᄡ ᄡᄡ cᄡi ᄡᄡᄡki cᄡᄡqvRbxqZv ᄡK ?

B) iᄡbᄡᄡj-K cᄡæ

1. DĒg Kgᄡᄡ=úv` ᄡbi Rb` mvgvRK cᄡi ᄡᄡᄡki ᄡᄡgKv eYᄡv Kiab |

mᄡK DĒi : A) 1| M 2| K |



Povřıgj`ıqb-1

A) eı ıbePbx cřke

mıWK DĚi ıbt` Rgj-K AřıııK eĚııqZ Kiab | (D`ınıY: Avcbri ıbePZ DĚiıW K ntj GřK ⊗ eĚııqZ Kiab)

- 1/ ıKřıvi gvb ej řZ ıK tevřıq ?
 - (K) AvřRıZK fıře `řKZ.gvb
 - (L) AvĀıj K fıře `řKZ.gvb
 - (M) ıKřımsıKó mğıRb KZř `řKZ.gvb
 - (N) cĀZôvb cĀvb KZř ıbaııı Z gvb

- 2/ ıKřıvıřbtK mřZR Křı ıKřm?
 - (K) řbZvi `ř`ıř Ges eııj ô KgĚııZ
 - (L) mıKvřıı meRbxb `kĚ
 - (M) cĀvb ıKřıřKı eııMıZı
 - (N) mğıřRı MY`gvb` e`ıııı řZRıı`Zı

- 3/ ıKřıv cĀZôvb Av`k`ıvıřq ıK fıře řZ cvřı?
 - (K) cĀZôvb Dbqřıbı Rb` eo aıřıbı FY Mřıřıı gva`řg
 - (L) Dbř ř`k ř`řK řııM` cřıııK fıııv Křı Gřb
 - (M) mııııY cřıııřıbı Avbřıj` Av`ıq Křı
 - (N) cĀZôvb cĀvřıbı ıeřkı řKřkř cĀqıřııı gva`řg

Av) msıřıB DĚıgj-K cřke

- 1. ıKřıvi gvb ıK ıK AvıřřıK ıePıı Kıı nq?
- 2. ııřZıı ı K ř`řK MZıvıııZK I Dbř ıKřıv e`e`ıvcbı ıııııgřııı cı`R` ıK?
- 3. řbZvi `ř`ıř řKgb nı qı cĀqıRb?
- 4. PıKřıı řřıřı` řKııZı cĀqıRbıřZı ıK?

B) ıPbıřıj-K cřke

- 1. ıKřıvi gvb ııııÖZKıřıı Dcıřq`řıı AvřııPbıı Kıab |
- 2. ZıııřZ h`ı`řKřkř AvřııPbıı Kıab |
- 3. "Vision with action can change the world" ej řZ ıK tevřıq ?
- 4. mı`R ıKřıv e`e`ıvcbıřq ms`ııZı fııgKıı AvřııPbıı Kıab |

mıWK DĚi :

A) 1| M 2| K 3| N|

ტკიბ დჭიკ იბტყ ავივი კირ კიუ, ავივი კი მუიკ ცსიყ ამიხი ნიუ, აიეიZ გჯ-ვიტი გვატგ ავიტი ი ციქტივი დეი ლტრ თეი კიტიZ ნტი|

Review ინZვი

ცხუიZი ცხივი კირიუ Review ინZვი-კ ნტიZ ნტი| იკივიყ დბაბ კიტირი მტი_ რიოZ _ვიტი იკივი, ცივიკ Ges EaYb KgRZNY| GB Pტი მხივი მუი,3 ციტიტიკი ბორ ბორ კიტირი რბ Review ინ კიტიბ| ივიჯი გიოტიკ პივი ტკიბ აეკვი ხი ტპტიბ _ვიტიკ Zვი ნტი ცხივი პი აკიხტი ნტი ხიტი| ციტიკიუ ეი3 ხივი ცხუიZი გტი კირ კიტიბ Zვივი მკივიტი Ges ციკივიციბ ნტიბ|

ცივირბიყ ატი ი თუმიბ

A_რიეტი მკი ტიტი ცივირბ| AZGe ციტიბი ცივიტი ბვი ხ_ვი_ ატი_მიეივი _ვიტი| ატი_მიეივი იეიბ აბივიტი ნტი| A_ავიტივი Ges აცტიკი თბ ტკიბ დიკ გტი ბრ _ვიტი| იკივი გიბ დბაბ ავივი იკივიტი პიუ, KZUKZPვი Zვი რბ ავიტი ი ტსკიMZ ი კ იკი კიტიZ ნტი Ges ტსკი აბივი კტი იკივი ბ, ცივივი მიხი, დივიტი ცივი, ტიხი დეივი მენკიკიტიZ ნტი|

იკივი გიბ დბაბ მტირი მუი,3 Zვი

იკივი ბ მტირი აიეტი_ A_2| მტირი მუი,3 Zვი იკივი jvf I ცივიტი მნივიკ| Zვი მტირი მეტი ი გიბტი რივი დიტი ავიტი ი იკივი A_2, ტივიტი კი ნუტი| ხი ნუტი Zვი დბაბივი ნტი მტირი დიკი.ნტი| ავი Zვი ხი დბაბივი ბრ ნტი ი_ვიტიკ ცი, Zტი G Ae_ტი_ტი იბი. ცივი დივი ლტრ თეი კიტიZ ნტი|

მივიტი გჯ-ვიტი

ტიტი იკივი ციტიბ, ტივიტი კი ნუტი Zვი აიეიZ გჯ-ვიტი გვატგ კიტიტი ტიტი ავიტიZ ნტი| თ აევიტი-კ კიუ ტიტი გ, ტივი ტიტი ბტი გჯ-ტივა ციტიბი ციტი ხტიკი ნტი მტივიტი Zტიტი კირ კიტიZ ნტი|

DchY ეე-ვიტი

იკივი ეე-ვიტი იტი ატიტი ატიკ ტიტი ციტიბი გიბ იბივიტი ნტი ხივი| AZGe ეე-ვიტივი ტიტი იბტი ბტი კივიტიკი ცივიტი კტი ციტიბ, ტივი აევიტი კტი ZტიZ ნტი|

ჯიყ ციტი

ეე-ვიტი ცივიტი მი_ტივი იბტი კტი `ჯიყ (Team work) კიხივი დი | `ჯიყ ეუბ ხტი მიტი ნტი `ტი კიხივი ZZ ფივი ნტი| Zტი `ტი იევიტი ტივიტიკი _ვიტიკი Ges Zვი ცივიტი კივი ტივიტი _ვიტიკი მტირი დეი დი ცივიტი მე ნი| იევიტი იკივი_ტი ავიტი ავიტი I `ტივი ატიბი ცი რიბ I რივიტი ტივიტი თუმი ნტი ფივიტი Kგრიეტი მივიტი Ges A_ე_ცივიტი ბი რბ| თ იევიტი GB ცსიყ იკივი_ტი ი მტირი ტივიტი ციტი ბ ტივიტი ფივიტი იკივი_ტი ავიტი|

GB ავიტი ბრ ტიტი ტივიტი ხივი იკივი ბივიტი მივიტი იკივი I ეე-ვიტი იბიტი კიტიZ ცივიტი იკივი_ტი ი ტივიტი, Y ევიტი ცივიტი| GB ტივიტი, YB GKRბ ეიტიკი `ტი კტი Ges აიეიZ `ტივი ატიბი მნივიტი კტი _ვიტიკი| გი დტი იკივი j` I დტიკი მივიტი ნი Ges იკივი გიბ დბაბივი მტი_ მტი_ `ტი გიბემუი_ მიტი დტი|



civ̇V̇i gj̇v̇q̃b 2.1

A) eú v̇beP̃bx c̃k̃æ

ṁv̇K ḊEi v̇bṫ Ṙgj-K Ȧŋi v̇ṫK ėḞv̇q̃Z Kiab | (Ḋv̇niY: Aiv̇bri v̇beP̃Z ḊEi v̇U K ṅṫj ĠṫK (K) ėḞv̇q̃Z Kiab)

- 1| v̇k̇ŋi v̇ib Ḋḃq̃b Kiv̇ḣeij K̇ṫV̇i Reveiṙ v̇nZiv̇j-K ṅṫZ ṅte ṫKb ?
 - (K) Reveiṙ v̇nZiv̇j-K ėv̇v̇ c̃Z̃ôv̇ṫbi ṁḃv̇g evoṙte
 - (L) Reveiṙ v̇nZiv̇j giv̇Uv̇is c̃ẋv̇Z ṁṖj iv̇L̇te
 - (M) giv̇b Ḋḃq̃b c̃P̃óv̇q̃ v̇eṄȧv̇U̇te v̇r
 - (N) ṁKj v̇ṫi ṘḃMY ṁṘv̇M v̇K̇te

- 2| v̇j̇xq̃ v̇ṁẋv̇ṧK̇ḟv̇te v̇k̇ŋi v̇ib Ḋḃq̃b K̇ṫi ?
 - (K) v̇j̇xq̃ v̇ṁẋv̇ṧK̇ḟv̇ṫi ṫK̇ L̇j̇ẋ K̇ṫi
 - (L) v̇j̇xq̃ v̇ṁẋv̇ṧK̇ḟv̇ṫi K̇v̇i ṫẎ K̇v̇Ṙ ṁṅṘ ṅq̃
 - (M) Eȧv̇Żb Ges Aȧ v̇bṫ i ġtȧ ṁȧúK̇ḟij̇ K̇ṫi
 - (N) v̇j̇xq̃ v̇ṁẋv̇ṧK̇ḟv̇ṫi AŻ v̇ṧḊḃż ai̇ṫbi ṅq̃

A) ṁṡv̇ŋ̇B ḊEi c̃k̃æ

- 1. v̇j̇xq̃ v̇ṁẋv̇ṧK̇ẋ ?
- 2. v̇k̇ŋi v̇ẋ i ṫck̇v̇MZ Áiv̇b K̇L̇b ėv̇ẋ ċv̇q̃ ?
- 3. ḃŻb gj̇v̇te v̇ȧ v̇k̇ḟv̇te c̃Z̃ôv̇ K̇iv̇ ḣv̇q̃ ?

B) iṖbv̇q̃j-K c̃k̃æ

- 1. ṫck̇v̇MZ giv̇b Ḋḃq̃ṫb av̇iv̇v̇ṅK giv̇b Ḋḃq̃b c̃P̃óv̇q̃ v̇k̇ḟv̇te ṁv̇ṅiḣv̇ K̇ṫi ?

ṁv̇K ḊEi :

A) 1| M 2| L|

- (O) gvb ubqšY Ges mv_R e`e`vcbvi ubōqZv
- (R) AZ`šÍ fivj fivte m`úvwi Z Kvhfeyj kbr³KiY
- (S) cāvb kZfeyj kbr³KiY
- (T) mKj DcvĒ meḱdY Kḱi mePvi Kiv ev im×všÍt`I qv
- (U) meḱkōl Z cāZte`b mvariḱY` cōKiv|

bxwZ Kivvḱgv Ges cūmwzKZv mePvi Kḱi gj`vqb Kiv ntj mwZ`Kvḱii gj`vqb tei Kiv m`e nq Ges Zv ev`ēḱḱḱḱ cōqum Kivl m`e nq| GUV memgqB gḱb ivLḱZ nḱe ukḱvi gvb Dbqḱb ukḱK Ges ukḱv_xP Dbqḱb Qvov m`e nq br| ukḱv eḱĒi tKv`^a me`šZ Ae`vbKvix ukḱv_xGes Zvi cwi waḱZ Ae`vbKvix ukḱK -G`RbḱK meḱePbrq br Gḱb hZB cwi Kí br I e`e`vcbv Kiv tvvK Zv mv_R nḱZ cvḱi br|



cvḱVĒi gj`vqb 2.2

A) eū ubePbx cĕæ

mivK DĒi ubḱ`Rgj-K AḱiUḱK eḱvqZ Kiab| (D`vniY: Avcbvi ubePZ DĒiU K ntj GḱK eḱvqZ Kiab)

- 1| ukḱvi gvb ubaḱḱY KigvU cōqvRb tKb ?
 - (K) KigvU gvb ubaḱḱY Kij mKḱj tgḱb ubte
 - (L) KigvU MVb Kiv GKvU ti I qvR
 - (M) KigvU m`fivte mePvi Kḱi gj`vqb KḱZ cvḱi
 - (N) KigvU gva`tg gvb ubaḱḱY Kiv RivZxq ti I qvR
- 2| ukḱvug I cv`mivPi chḱjvPbvi cōqvRbxqZv Kx ?
 - (K) ukḱvi AvavbKvqb
 - (L) ukḱv e`e`vcbvi mjev Kiv
 - (M) ukḱv`vb c×vZḱK KvhRix Kiv
 - (N) ukḱK I ukḱv_xP i gḱa`mL`Zv`vcb

Av) msuḱB DĒi cĕæ

- 1. ukḱvi gvb Dbqḱbi Rb` Kx Kx mel q meḱePbrq ivLḱZ nq ?
- 2. ukḱKZvi gvb hivbḱḱi Rb` Kx Kx mel q cwi Kí brq AvḱZ nḱe ?

B) iPbvji-K cĕæ

- 1. ukḱvq A`ḱqb bxwZi dj vdj ,ḱj v Avḱj vPbv Kiab|

mivK DĒi : A) 1| M 2| L|

cÖZövtK fije vmtZ nte Avevi cÖZövtKI Zvi tjvKetji mthvM mveavi
hšMvcthvMx unmvte w`tz nte|

**ik`ivi gvtbvqtb
`jMZ e`e`icbvi
iazi**

Dbz` t`k, tjvZ MtelYvq t`Lv wMtqtQ th mKj cÖZövtb mggbv gvbly`j Mvb Kti
GKVZVZv cKik Kti GKthvM KvR KtiQo tmLvtbB Awz`az` cwi eZB` mvaZ ntqtQ,
cÖZövtbi Dbz` ntqtQ, cÖZövt t`tk ik`iv`x`v bZb bZb aviYv jvf Kti t`tki
Kj`vtY vbtqmRZ ntZ tctitQ| Zv ntj tevSv hvq mveR` ik`iv` e`e`vi Dbqtb`j
e`e`icbvq`azzi nq Ges Z m`e Kti tZvtj ik`iv`x`i`i`YMZ gvbm`ubae`ir`tz;
cwiYZ Kitz| ik`iK, ik`iv`x`cÖZ`tkB`YMZ gvbm`ubae`ik`ivi cÖ`vkv ntj ik`ivi
AMMvZ mvaZ nq| GB cwi tek mRbxkiv` meKv tk mrvh` Kti| Avb I`qZv
`vbr`š`i I GB cLqv mrvqK| mgm`v mgvavtb mRbkxj Zv AZ`š`i`iaZc`f`ugKv
cij b Kti| th tKvb cÖZövtbi`tj`vefb`e`atbi tjvK`_vtK| Zviv`vefb`e`mgm`v
vefb`e`vte mgvavtb cÖ`le Kti| Avevi D`v`ebx KvRI Zvt`i f`ugKv AMM`Y`_vtK|
Avi`j`teK KivRwi nq hiv` Gi Aš`f`v` tjvKRb`vefb`e`y`x` c`k`iY Mh`Y Kti`_qZv
ARB` Ktib| hiv`cvi`kr`tbZv`tj`i`cwi Pvj K`_vtKb Zte`jMZ KvR AZ`š`i
mš`i I RbK nq|`tj`vefb`e`cÖZ`fvi tjvKej`_vKtj Zviv`vrbv`ti KvR Av`vtq mg`
nq|`tj`i mg`i KvR vbf`P` Kti vbtPi Pviu k`z`P` Dci:

**`jxq KvRI
mdj Zvi kZ**

- `jtbZvi cÖ`qx kc`_
- `qZv Dbqtb`vebtqm
- `tj`i`tjvKetji`mKj`aitbi`KivR`Kivi`m`qZv
- `tj`i`mKj`tjvK`vbR`vbR`KZ`e` I`v`vqZ`cij`tb`cÖ`qx`nI`qv

c`xv`ZMZ e`e`icbvi tKš`kj

**v`bqvZ tiKW`
msi`iY**

Total Quality Management Group -Gi me`ic`iv`i`iaZc`v`KivR`nj`mKj`NUbv`I
unmvec`ti`i`v`bqvZ`ti`KW`msi`iY`Ges`mgq`mgq`Zv`ch`ej`vPbv`Kiv|`GB`ch`ej`vPbv
t`tk`cÖZövtbi``v` I`mej`w`K,`tjv`mnt`RB`c`k`v`k`Z`nq`Ges`mš`t`v`ab`rg`-K`e`e`v`
Mh`Y`m`e`nq|

**v`ba`v`i`Z`mPK`Ablyvq`
`v`vqZ`i`cij`b**

me`v`v`Z`v`tg`Mpx`Z`mPK`_tjv`tgtb`KivR`Kiv`c`xv`ZMZ`e`e`icbvi`GKiv`Ab`Zg
tKš`kj`|`mKtj`B`hiv`_`k`Z`mPK`Ablyv`Y`Kti`_v`vqZ`i`cij`b`Kti`Zv`ntj`c`k`v`m`b`K
KivR`nvén`ntq`hvq|`cÖZövt`mnt`R`D`v`v`ebx`v`š`i`avivq`aweZ`ntZ`cvti`|`thgb`-`ik`iv`
cÖZövtb`k;Ljv`mgm`v`GKiv`Rivj`ielq|`k;Ljv`i`qvi`_v`vqZ`i`hiv`_vtKb`Zviv`hiv`
`p`cÖ`qx`nb`th,`GB`mgm`v`cÖZövt`c`v`b`ev`cwi`Pvj`bv`cl`P`i`Kv`Q`v`btq`hv`eb`bv;
Av`c`v`Y`t`Póv`Kti`mgvavb`Kiteb`Ges`mgm`vi`hv`Z`c`yivq`D`v`e`bv`Nš`U`Zvi
c`v`Z`i`v`agj`-K`e`e`v`Mh`v`Y`mš`Pó`_v`Kteb`Zvntj`cÖZövtbi`t`Pniv`B`Avj`v`v`ntq`hv`te|

**j`q`AR`v`bi`Dcvq`
v`Pv`y`Z`Kiv**

j`q`AR`v`bi`Dcvq`_tjv`hiv`_v`Pv`y`Z`_vtK`Ges`AZ`š`i`v`š`i`f`vebvi`mš`_`G`_tjv`v`ba`v`Y
Kiv`nq`A`_v`gvbm`v`Z`nq`Zv`ntj`mnt`RB`cÖZövt`cÖZövt`jvf`Kti|

**cÖZövtbi`mdj`
BivZnm`v`j`v`ce`x`Kiv**

cÖZövtbi`mdj`_`BivZnm`hiv`_v`j`v`ce`x`_vtK`Ges`GB`mdj`_`c`xv`ZMZ`f`v`te`civ`q`v`Kiv
nq`Ges`Zvi`D`i`k`_`hiv`_`Dbqtb`nq`Zte`GB`v`biv`q`v`f`iel`t`Zi`AtbK`D`3`4`j`c`_`L`
t`te|`Aek`B`g`tb`iv`L`t`Z`nte`mdtj`_`i`BivZnm`thb`nvi`tq`bv`hvq|`mdtj`_`i`BivZnm

z Ae GWNKkb

chij vPbv t_tK cñZömbK `gZv_s tjv cKvinkZ ntq hvq Ges G_s tjv `i Kti bZb
wPŠi fvebv msthvRb mæ nq| mvdjt `i BwZnvtm wbtgæDij mLZ wēl q_s tjv _vKte|

- wbtqvM c×wZ
- cñkŕjY ariv
- Kvh©c×wZ
- cy^-vi bwwZ
- kw-lbwwZ
- ÷vd c^vUvb©
- Kvh®m^úv`b ariv
- DrKI©`i
- cZ^vkv
- cñB
- AcñB
- DbwZi AMñwZ (Kvi Y wētkŕ Y)
- DbwZi AaMwZ (Kvi Y wētkŕ Y)

mv_ŕfvte mvgwMk gvb Dbæb e`e^vcbv ev^vrbq KitZ cvitj wbtgæ mj_j_s tjv
cñZfvZ nq|

**mvgwMk gvb Dbæb
e`e^vcbv mj_j**

- DPz^`i i AvZ^cZ`q AR®
- gvb mæZ KvR Kivi AvMñ m^
- Aaxb ^`i wēkŕmfvRb nI qv
- EaŕZbt^ i Av^v AR® Kiv
- Nb Nb ÷vd cvv eZ® cēYZv Ktg hvI qv
- Kg ŕUmb nI qv
- ØØ wbi m^b mg_`nI qv
- KvŕRi mšw jvf Kiv



ciVvEi gj'iqb 2.3

A) eU ʔbePbx cʔæ

mivK DEi ʔbʔ Rgj-K Aʔi ʔuʔK eEʔiqZ Kiab | (D`vniY: Avcbri ʔbePZ DEi ʔU K ntj GʔK  eEʔiqZ Kiab)

- 1| gvb Dbqʔbi Dʔi k ʔ ʔbaʔ Y ej ʔZ Kx tevSvq ?
 - (K) gvb Dbqʔb Kx Kx c ʔʔc MʔY cʔqʔRb Zv kbv³KiY
 - (L) ʔgavm=ubʔʔj vK ʔbʔqʔM Kʔi gvb Dbqʔbi e`e`v Kiv
 - (M) ʔe`gvb ʔj vKetj i teZb Dʔj ʔʔhʔM`firte eʔx Kiv
 - (N) mgvʔRi MY`gvb ʔj vKʔ i m=ú³ Kʔi Dbqʔb cʔPóv MʔY

- 2| gvbimK eʔx ej ʔZ Kx tevSvq ?
 - (K) Zʔ` eqʔmi ʔʔʔq teʔk Rvbr
 - (L) AvZ mʔR `ʔeʔa` avi Yv ü`qʔg Kiv
 - (M) eqʔmi mʔ_ mvgÁm` ʔi ʔL eʔx eʔEi meʔaK ʔeKiv
 - (N) PZgʔx Ávb ARʔ Kiv

- 3| ʔKvb cʔZóvʔbi mvdj` BvZnvm ʔeʔkʔ Y Ki ʔZ nq ʔKb ?
 - (K) G BvZnvm cvV AZxZ NUbveʔj `ʔi Y Kvi ʔq ʔ`q
 - (L) eZóvʔbi mʔ_ AZxʔZi Zʔbv Kʔi ʔePvi ʔeʔkʔ Y Kiv hvq
 - (M) mvdj` BvZnvm ʔeʔkʔ Y bZbʔ`i Dʔy Kʔi
 - (N) mgq mgq G BvZnvm ʔeʔkʔ Y fivl`ʔZi bZb m=ʔebri c_ cʔkʔ Kʔi

Av) msiʔʔB DEi cʔæ

- 1. ʔkʔvi gvb Dbqʔb ʔKfirte nʔZ cvʔi ?
- 2. cʔZóvʔbi mKj NUbv Ges ʔnmvecĀ msi ʔʔʔYi cʔqʔRbxqZv Kx ?
- 3. mvdj` BvZnvm Kx Kx ʔel q _vKv cʔqʔRb ?

B) iPbvqj-K cʔæ

- 1. ʔkʔvi gvb Dbqʔb ʔKʔkj `ʔj v Avʔj vPbv Kiab |

mivK DEi :

A) 1| K 2| M 3| N |

**YMZ g`tbi Rb`
MpxZ maviY c` t`q**

1. mgm`vi `xZ mgvavb
2. AvZwi` cwi eZB` bv Kiv A` g`-WK ti tL bgbxq cwi eZB` Avbqb
3. cieZx`NUbv NtU hveri AvtMB cwi Kí bv Kiv
4. cZwU KvR thS`K nI qv
5. tewki fVM t`q`T` q`gZvm`úba`tbZvi KZ`j t`g`b tbevi c`Yzv
6. MZvbMvZK c`wZi evB`ti bv hvl qv

**YMZ g`tbi t`q`T`
tbZtZj tKSkj**

uKŠ` tbZtZj t`q`T` mvguMK Dbq`b e`e`vcbv KZ`tjv tgšij K aviYv ev Assumption Ges tKŠkj ev Strategy ubtq KvR Kti | aviYv`tjv ubgijc :

1. tbZv n`eb Kí bwej vmx, q`gZvq`tbi c`q`cvZx Ges mvg`f`v`EK |
2. tbZtZj Kvhšiv m`Avi Z Ki`te, Ab`tk civgk`t` evi, cwi Pj b Kivi I m`vK w`K ubt`Rbv c`v`tbi q`gZv`vKte |
3. tbZv mKj KvR cost-effective Kivi thvM` n`eb |
4. tbZtZj Ggb`w`f`w`z`vKte thb wZub me`q`T` mePiY Ki`Z cvtib |
5. q`ž`w`Z`q`ž`w`R`ubm hv we`a`v`š`l`N`U`r`Z` cvti Zvl Zvi Avb m`vqv ivL`Z n`e |
6. Zv`K g`tb ivL`Z n`e P`v`j`Ä Ges gvb GKm`v` P`j |



cv`Vv`Ei g`-vqb 2.4

A) eú ubePbx c`k`e

m`vK D`Ei ubt`Rg`j`K A`q`i`w`t`K e`f`v`q`Z Kiab | (D`vniY: Avcbvi ubeP`PZ D`Ei w`K ntj G`tK (K) e`f`v`q`Z Kiab)

1 | tbZtZj e`e`vcbv G`v`c`ú`P ms`w`Z`K g`-we`teP` w`el q` w`ntm`te aiv n`t`q`Q tKb?

- (K) ms`w`Z. g`v`b`y`t`K AZxtZi K`v`š`i Y Kwi`t`q` t`q
- (L) c`Z`K R`w`ZB Zvi ms`w`Z. i Dci`w`t`q
- (M) ms`w`Z. AZxtZi m`v`_ f`w`el`t`Zi tmZ`E`U` i Pbv Kti
- (N) ms`w`Z. w`R`-g`j`-te`v`ta D`š`y` n`t`Z m`v`v`h` Kti

2 | tbZtZj q`gZvq`b Kx ?

- (K) tbZvi L`y`kgZ q`gZv c`ú`qvM Ki`Z cviv
- (L) civgk`p`t`g` tbZvi q`gZv c`ú`qvM Ki`Z cviv
- (M) tbZvi thS`K`f`v`te q`gZv c`ú`qvM Ki`Z cviv
- (N) Aa`b`i` K`v`vi k`v`m`t`bi g`ta` ivLv

Av) ms`v`q`B D`Ei c`k`e

1. TQM c`w`Z w`K`mi Dci`w`f`P` Kti Kvhšiv v`ba`f`Y Ki`Z nq?
2. w`K`q`vi gvb Dbq`tb`i`w`i` c`ú`qvR`bxqZv Kx?

B) iPbv`j`-K c`k`e

1. tbZtZj m`me`R` e`e`vcbv G`v`c`ú`P w`K`q`vi gvb Dbq`b c`w`Z Avtj`v`Pbv Kiab |

m`vK D`Ei : A) 1 | L 2 | M |

3. cŕZŕnbK Dbŕb mŕúŕK©mKtj wj ũLZ mgvwi k iVLte Ges Avtj vPbri wfiÉtZ KivQivMŕ, tj v MŕY Kiv nte|
4. eo `j tK tfŕ½ tQvU tQvU `tj Avtj vPbv Kti mgvũMŕ weiqe` mvariY mfvq Dc`rcb Kiv hvq| meŕPŕq RũUj APj ve`v `i Kivi Rb` e`ir³MZ e³e` ũbŕq tbZvMY ũmŕvšl tbŕeb|
5. Ávb, `ŕZv l `ŕfũ½RũbZ mgm`v ev APj ve`vi gj- KivY weŕkŕŕYi gva`tg tei KiŕZ cviŕtj B mKtj i gŕa` mšŕŕ Avŕm Ges gvŕb Dbŕqŕbi c_ cŕk`ŕnq|

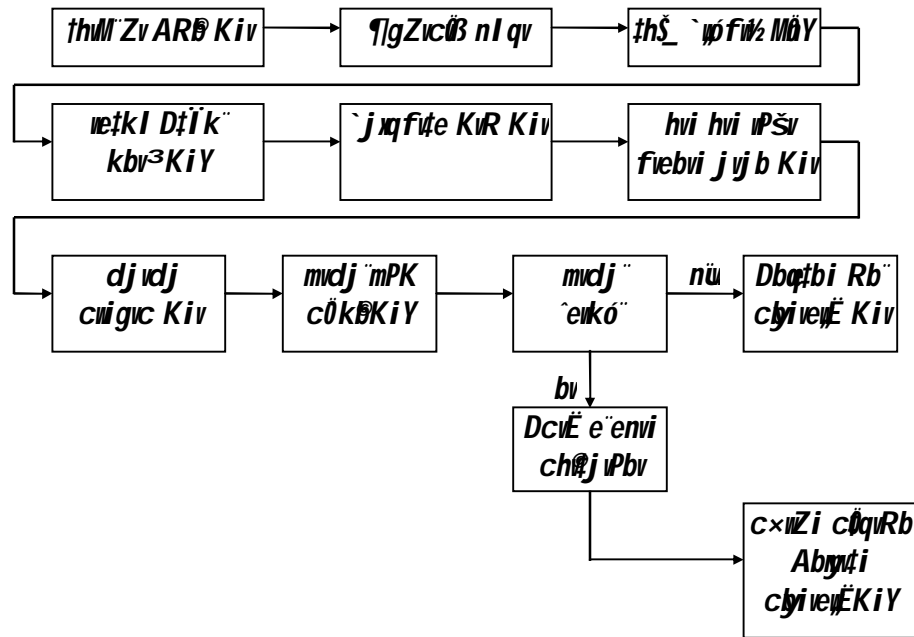

ũPŕ 2.5-1 : Kivŕix `tj i Kivŕej

gvŕb Dbŕqŕb ũmŕvšl mŕŕvšl APj ve`v ũbimŕŕbi Rb` ũbeŕPZ weŕvŕb Ges cŕũZ tj vŕKi AskMŕŕŕY lqvKŕc, tmŕgbri Kiv thŕZ cviŕ| e`vcK Avtj vPbvq AtŕŕKB ũbŕRi ŕ`vlŕŕũU eŕŕŕ `ŕŕfũ½i cŕieZŕ NUŕŕZ cviŕ| cŕŕZ`ŕKB ũbR ũbR KivŕRi thM`Zv ARŕ Kiŕtj, KZŕŕŕ mKj tK mŕa`gZ ŕlgZvŕq Kiŕtj Ges mKtj mŕŕŕŕj Zfŕte `i`ŕŕ MŕY KiŕZ cviŕtj mKj APj ve`vi ũbimŕ nŕq hvq|



CVtVĒi gj'vqb 2.5

A) eū vbePbx cġæ

mūWK DĒi vbt` Rgj-K Aq̄i vjtK eĒvqZ Kiab | (D`vniY: Avcbvi vbePZ DĒi vj K ntj GtK Ⓚ eĒvqZ Kiab)

- 1/ vofwz mūWK APj ve`v vbm̄bi cġqvRbxqZv Ki?
(K) vq̄v cġZōv̄bi tKv`j cv̄nvi Kiv
(L) mKtj vq̄j vq̄k eŪĒvevcb̄m̄l qv
(M) ci`v̄ītK Dbq̄bgj-K Kv̄tR m̄v̄v̄h̄ Kiv
(N) vevfb̄e` vofwz v̄v̄ ev̄x Kivq Dbq̄b e`vnZ nq

- 2/ Dbq̄b cġqvq mKtj i gta` mšiv̄ Av̄tm vKfv̄te?
(K) mKj tK v̄v̄ vbm̄b Drm̄v̄nZ Kt̄i
(L) Dbq̄b cġqvq mKj tK mū³ Kt̄i
(M) veḡk̄t̄Yi gva`tg APj ve`vi gj' v̄iY Lv̄R̄ tei Kt̄i
(N) v`K vbt` Rbv̄gj-K civ̄gk̄c̄v̄v̄bi gva`tg

Av) msv̄v̄v̄ DĒi cġæ

1. cġZōv̄b e`v̄v̄t̄Z e`v̄v̄t̄Z th m̄gm̄v̄ v̄v̄t̄K Zv vKfv̄te v̄bim̄b Kiv hv̄q?
2. cġZōv̄bK v̄v̄ vbm̄b cġZōv̄bi m`m`MY vKfv̄te Kv̄QvKv̄Q Av̄m̄t̄Z cv̄t̄i?

B) iPbv̄gj-K cġæ

1. vq̄v̄vi gv̄b Dbq̄t̄bi Rb` vq̄v̄v̄ cġZōv̄bi APj ve`v vKfv̄te v̄bim̄b Kiv hv̄q?

mūWK DĒi :

A) 1| N 2| L|

cW 2.6

ik`qv cÖZövb ibix`q`iYi cÖqvRbxqZv

[Need for Audit of Educational Institution]

D`ik`

GB cW tk`I Avicvb –

□ ik`qvi gvb Dbq`tb ik`qv cÖZövb ibix`q`iYi cÖqvRbxqZv e`vL`v Ki`Z cvi`teb|

AvRKjy ik`qv cÖZövtbi gva`tg A_`DcivR`bi cÖYZv µgk ep`x cvt`Q hw`I ik`qv cÖZövbmg`r mivavi Y A`_`E`emv`f`q wj B bq| ik`qv cÖZövbmg`rni Av`tqi cÖvb D`rm nj miKvvi I AvavmiKvvi g`Ajx, Qv`I`teZb, mgv`r`Ri abx e`v`v`v`i`i` `vb, U`v`-KZ.m`v`v`E BZ`w` | GB me Avq t`_`tK cÖZövbmg`rni e`q vbe`v`n nq| ik`qvi gvb Dbq`tbi Rb` Gme A`_`p GB A`_`m`v`K f`v`te LiP bv AcPq ev AvZ`m`v`r nt`Q Zvi cÖZ`v`i`v`agj-K e`e`-v M`h`Y cÖqvRb| GRb`B cÖqvRb wnmve ibix`q`iY| wnmve ibix`q`iYi cÖqvRbxqZv cÖvbZ wZb`v`U Kvi`f`Y| Kvi`Y, t`j`v` nj :

wnmve ibix`q`iYi cÖqvRbxqZv

- AcPq tiva:** AcPq tiva Kivi Rb` wnmvei`q`iY I AcPq tiva AZ`š`l, ia`z`c`Y`p cÖZövtbi e`qmg`rni LvZw`f`v`EK mg`z`wnmve msi`q`iY Kiv nt`j e`t`qi Z`j`b`v`g`j-K vepvi vekt`k`i`f`iYi gva`tg th th t`q`i`f`I AvZ`v`i` v` e`q nq Zv v`b`q`š`y Kiv m`v`e`| ik`qvi gvb Dbq`tb ZvB AcPq tiva Avek`K|
- cÖZövtbi Dbw`Z:** cÖZövtbi Dbq`tbi Rb` cwiK`i`bv cÖqvRb| cwiK`i`bv h`j`Mi P`v`v`v`v` tgUv`f`Z bv cvi`t`j A`_`p AcPq N`t`U| ZvB cÖZövtbi Dbw`ZK`f`r wnmvei`q`iY Ges v`b`ix`q`iY AZ`š`l cÖqvRbxq Ges ik`qvi, YMZ gvb ep`x`f`Z v`b`ix`q`iY AZ`š`l m`v`v`q`K|
- Reve`i`v`Zv I `wq`Z`f`eva v`b`v`ÖZKiY:** wnmve msi`q`iYi mg`Z`v` m`v`k`v` e`v`v`v`e`m`p`K Zv`q`i`w`YKf`v`te Reve` c`v`v`b` m`v`v`h` K`f`i| cÖZövtbi Dbq`bK`f`r Avw`_`R Ae`-v v`b`i`j`c`Y, bM` A`_`p Ae`-v Zv`q`i`w`YK AeMZ n`l`q`v`i` Rb` `v`q I m`v`v`v`E`i` Dci v`b`q`š`y ivLvi Rb` wnmvei`q`iY I v`b`ix`q`iYi v`el`q`v`U AZ`š`l, ia`z`c`Y`p

Avq e`t`qi wnmv`f`ei g`j`b`w`Z

Avq e`t`qi wnmv`f`ei t`q`i`f`I Avv`y`Ze` g`j`b`w`Zmg`r v`b`t`P D`t`j`L Kiv nj |

Avqb-e`qb Avd`m`vi: cÖZövtbi Avw`_`R v`v`v`v`v` Avb`y`q`x v`b`t`q`v`M`c`v`B Avqb I e`qb Avd`m`vi Zv`i` Dci Avv`Z `v`w`q`Z`j` cvj`b Ki`teb| wZv`b cÖZv`v`t`bi Avw`_`R t`j`b`f`b` m`v`k`-ö t`i`v`R`v`v`i` wj v`c`e`x Ki`teb Ges `b`w`b` wnmve v`b`v`v`v`v`v`K`f`i `v`q`i` c`v`v`b` Ki`teb|

`b`w`b Av`t`qi A`_`m`i`v`v`i e`v`st`K Rgv t`I`qv: `b`w`b` th Uv`Kv Avm`te Zv t`_`tK `b`w`b` Li`f`Pi Rb` v`b`v`v`i` Z A`_`p AvZ`v`i` v` K`v`k` e`v`st`K Rgv c`v`v`b` Ki`Z n`te|

Avb`g`v`i` Z ev`R`f`Ui v`f`v`E`f`Z t`j`b`f`b` Kiv: t`K`v`b` Ae`-v`f`ZB Avb`g`v`i` Z ev`R`f`Ui AvZ`v`i` v` LiP Kiv Dv`PZ bq|

e'isK t_#K tKej c0qRbA A_@D#Ej b: c0Z0mbK c0qRb Qvor e'isK t_#K A_@
D#Ej b mgrPxb bq|

^bw`b Avq-e'tqi nmme msuk0 K'ikeB I tiuR÷v#i yj uce×KiY: Avq-e'tqi nmme
msuk0 K'ikeB I tiuR÷v#i yj uce×KiY nmmei #tKi `wqZj| nmmei th tKvb
i Ktgi Moeo cwinvi KitZ Zv AZ'vek`K|

gvm tk#l e'isK t÷Utq#Ui m#½ K'ikeB Gi nmme wj v#v: gvm tk#l e'isK t_#K
t÷Utq:U msl#h K#i K'ikeB Gi m#_ wj v#v t`L#Z n#e|

Kugw / teW@/ nek#e`vj tqi AbgnZ e`ZxZ ni Rvf@d#U#i U#Kv D#Ej b bv Kiv:
c0Z0v#bi w#kl D#k" m#v#bi Rb" dvU Mvb Kiv nq Ges Zv c0Z0v#bi Aw_#
e#q#` gRey w#`#K| w#kl c0qRb t`Lv w#tj Kugw/teW@nek#e`vj tqi
Abtgv`b m#t#t# A_@D#Ej b Kiv th#Z cv#i |

÷K tU#Ks: Mfub# eWv KZ# g#v#v#Z `wqZ#xj Kg#Z#0v#v ÷K tiuR÷v#i i m#½
ev`e ÷K wj v#v Mfub# eWv w#KU m#t#vU#c0vb|

Avq-e'tqi nmme w#x#Y I w#t#vU#c0vb: w#q#Zfv#e c0Z eQ#i i tk#l Avq e'tqi
w#x#Y#Yi Rb" Mfub# eWv w#x#YK `j w#t#vU# K#eb| w#x#YK `j w#v#v tgvZv#eK
w#x#Y#i ci w#t#vU#c0vb K#eb|



ciVvEi gj`iqb 2.6

A) eú ubePbx ckae

mMK DEi ubt` Rgj-K AqjiWtK eEiqZ Kiab | (D`vniY: Avcbvi ubePZ DEiW K ntj GtK **(K)** eEiqZ Kiab)

1/ nmve ubixqtYi c0qvRbxqZv Kx ?

- (K) Aa`q / cwiPvj KtK A_mau`KqMZKqivLv
- (L) AcPq tivtai gva`tg ukqvi gvb Dbqg
- (M) ukqv c0Z0vtbK mPj ivLv
- (N) ukqv c0Z0vtbi m0vg MK ivLv

2/ e`qb KgRZPKvtK etj ?

- (K) ihub m0gMKfvte ukqv c0Z0vtbi LiPwi i KvR Ktib
- (L) ihub evtRU`Zwi Kti e`q Ktib
- (M) ihub c0Z0vtbi c0qvRbxq tKbvKvUv Ktib
- (N) ihub veva tgvZuteK c0Z0vtbi A_e`q Ktib I Zvi nmve ivtLb

Av) msuqB DEi ckae

1. c0Z0vtbi Avq-e`q ubixqtYi c0qvRbxqZv Kx?
2. Avqb-e`qb Avdmvti i`vqZ; Kx?

B) iPbvqj-K ckae

1. Avq-e`tqi nmvti gj-bmZ, tj v Avtj vPbv Kiab |

mMK DEi :

A) 1/ L 2/ N |

th melq, tju Dtl Kiv nj G, tju gvb Dbqb Ges msi qti Yi Rb` cwi gvtci K_v memgq gtb ivLtz nte| mivK Z_` wekdt yi gva`tgB tKej G, tju gvb WK ivLv Ges Dbqb mae| Gtqti metptq Dtl thvM` melq nj meivKQB wbfptvM` Z_` wbtq KitZ nte|

**Z_` wekdt yi
bivZgvj v**

Z_` wekdt yi mgq Pviw bivZgvj v tgb Pj tz nq hv wbtP Dtl - L Kiv nj |

1. **mtgvP tkvwevM (Hierarchy):** e`e`vcvri cOZ`Kiv `litKB ,iatZi mvt_ t`Ltz nte| e`e`vcKMY G wltq AZ`sl mtpzb _vKteb| gvb Dbqb thtnZz ivZviviZ mae nq bv ZvB mgqi wefv`tz GKivR, tju m`uv`b KitZ nq| e`e`vcvri cOg `li KtqK mBiv t`tk KtqK gvm| wZixq `li KtqK gvm t`tk eQi, wbeix e`e`vcvri eQi t`tk `kK|
2. **DcvE Ges djvdj:** Z_` msMh Kti cOqvRvZKiY Ges h_vh_ wekdt yi gva`tg Dbqb KvR e`eniv KitZ nte|
3. **cOqvRvZKiY mgve`Zv:** th tKiv cwi Kiv bv cwi Pvj bvq `ti `ti mgve`Zv AvtQ| GK `li tktl Ab` `ti AtbK etav _vtK| ev`gEvi mvt_ G, tju AvZvg KitZ nq|
4. **cOsk Dtik:** tj Lv covi gj- j q` Kx, Zv `uofite tRtb `ti ci `li AvZvg KitZ nq| cOZw `ti metptq tek cOqvRb mZZv| tKiv KvRB tkl nq bv hv bv Zvi tkl Kx cwi`vi fite Rvbr _vtK| AZGe cOZ`K tcvMtg Rb` Dtik` mivKfite wbaq Y KitZ nte| hv mivKfite wekdt Y Kti KvR Kiv nq Zte wbtai djvdj , tju `k`Z tevSv hvte|

- * Kvi ZE`eavtb gj- KivR, tju mgvavb nte?
- * weivb`cOqvri KvRix wq_ w`Evi Kx?
- * KvRi `li , tju m`eb`-Inte|

gvb Dbqb GKiv avivvink mtpzb cOqv, Zv nVr `e`m`tg NtU bv| Zvi Rb` cOqvRb mivS, mivb`i Z, Dtik`m`ij Z cwi Kiv bv Ges cwi Kiv bv ev`evqtb cOqvMK c`vZ| Dbqb gvb`i mnRvZ cE`E| mKj gvb`yB Dbqb Pvg, Zte mKtj Rvrb bv wKfite Dbqb NtU| weivb`e`li cwi ntq Dbqb KvR`qZ chiq tcOQ| wbtæ mst`qtc chiq, tju Avtj vPbv Kiv nj |

**gvb Dbqb cOqvri
avivvink chiqmgn**

cOg chiq : mgvtRi mKtji Rb` wkvvi Dbqtb cOqvRb AvtQ| OcO`ovi gva`tg Dbqb mae`G AvtZ wkvK, cOvMk, wkv`v`x` AwffveK Ges mgvtRi MY`gvb` e`v`i gta` mAvjB cOqvRb| hv`i K_v evj nj Zviv mKtjB GUV Rvrb| wKs` Avgt`i t`tk cvej K cixqv`i iæ ntj t`Lv hvq cOg mKj chiqi gvb`y Kg covi`bvq DEg cOvi cE`vkvq tgz Dtv Ges AmvaycSv Aej`ab Kti Ges KitZ mivv`h` Kti| GLv`bB fij g`i`i` ØØ j`kvqZ, evvntii weteK Ges wFZtii weteKti j`KvPzi | GB ØØ Ges j`KvPzi wkv`v`z`tb Avgt`i wcvOtg w`t`Q Ges wkv`v`i gvb wbg`v`x` nt`Q| GUV Avgiv mevB ejSv bv eSvi fiv Kiv | G Ae`v t`tk cwi TvY cvlqvri Rb` me`ti i gvb`i GivMtg Avv cOqvRb|

cW 2.8

uk`ivi , YMZgvb I cwi gvc

[Quality of Education and Its Measurement]

D`i`k`

GB cW tk`I Av`cwb-

□ uk`ivi c`Z`ov`bi gvb Db`qb c`u`qv Av`j vPbv Ki`Z cvi`teb|

gvb I cwi gvc welq `w I Z`c`Z`f`v`te RwoZ| gvb ej`tj B cwi gvt`ci c`k`æG`tm hvq| tKbbv cwi gvcB gvb wba`f`Y K`i` | th tKvb c`Z`ov`bi gvb Db`q`b`i Rb` Zvi m`u`w` Z Kiv`Ri gvb hv`PvB Ki`Z nq| GB hv`PvB we`rf`b`æ`c`u`qv`q n`Z cvi` | w`b`g`æ`G m`st`q`i`c Av`j vPbv Kiv nj |

m`P`Z`b`v m`p`: m`P`Z`b`Z`v c`Z`ov`bi m`m`MY`k` c`Z`ov`bi Db`q`b`K`i` m`n`v`q`K Db`q`b K`j v`K`S`k`j Ges `w`f`w`z m`u`k`A`ew`Z K`i` | cie`Z`x`P`Z Av`iv M`f`xi avi Yv` t`j`v m`P`Z`b`Z`vi gva`t`g`B Av`tm| m`P`Z`b`Z`vi w`Z`b`w`U `i` -

m`P`Z`b`Z`vi `i

- uk`ivLv`Z M`h`x`Z`iv tKvb welq`u`i c`Z` te`w` , i`æ`j Av`iv`c K`i` Z`v D`c`j`w`ä Kiv Ges c`Z`ov`b -Gi uk`iv`x`p` i Kx Kx m`j`h`M w` t`Z cvi` Z`v m`j`w`w` `f`v`te e`v`L`v Kivi thv`M`Z`v AR`B Kiv|
- M`h`x`Z`v`i GB wel`t`q k`Z`K`iv 100 f`v`M w`b`w`Z` Kiv Ges Z`v c`æ`c`ö`E m`g`t`q c`ö`vb Kiv|
- c`Z`thv`M`Z`vg`j`-K ev`R`v`i w`U`k` _v`K`vi j`t`q`i` uk`ivi gvb Db`q`b`i Rb` Av`Z`wi`³ we`b`t`q`w`M; Kg Li`P` uk`iv`x`p`a`ti iv`L`vi Rb` D`t` `v`M`x` n`l`q`v; uk`ivi m`v`g`w`M`K gvb Db`q`b` a`ti iv`L`vi Rb` Ges m`g`v`M`Z gvb Db`q`b`i c`æ`Y`Z`v ewo`t`q t`Z`ij`vi Rb` c`j`i`v`c`v`j` m`P`Z`b`Z`vi m`v`t`_ Kiv`R Ki`Z n`te|

uk`iv`v`t`q`i` uk`iv`x`p`vB t`j`Z`v ev` M`h`x`Z`v| Z`vB gvb Db`q`b`i w`j`w`L`Z c`ö`l`te A`S`f`P` _v`K`te uk`iv`x`p`i A`f`ve ev` c`ö`qv`R`b`x`q`Z`vi aib| Avi c`ö`qv`R`b`x`q`Z`v ej`t`Z e`S`v`te uk`ivi cwi`te`k, `vb m`S`K`j`vb, uk`iv`m`g, cv`V`m`w`P, cv`V`c`y`K, uk`iv`t`K`i thv`M`Z`v, uk`iv` m`n`v`q`K D`c`K`i`Y, M`t`el`Y`ri m`j`h`M, c`Z`ov`bi L`w`Z B`Z`w`i | c`Z`ov`b`K R`bej`t`K m`P`Z`b`g`l`x Kivi Rb` c`ö`qv`R`b` nj :

c`Z`ov`bi R`bej`t`K m`P`Z`b` Kivi D`c`w`

- m`w`S`j` Z gvb Db`q`b`i Rb` m`S`-vi t`b`Z`v`M`Y`k` m`y`i`c`h`v`ix `w`o`m`u`b`e`n`t`Z n`te| c`Z`ov`bi I uk`iv`x`p`i c`ö`qv`R`t`b th`S`_f`v`te cwi`e`Z`b`i Rb` m`m`MY`k` c`ö`w`e`Z Kivi q`g`Z`v Z`vi _v`K`Z` n`te|
- m`K`j` `t`i`i e`e`-v`c`K`f`i G`K`thv`t`M Kiv`R Kivi `p`g`t`b`v`ej` M`to Z`j`t`Z` n`te|

- thfvteB Kvh©i Kíbv Kiv trvK bv tKb Zv thb , YMZgvb mæúbæng tmw`tK mKtji AweiZ `wó ivLtZ nte| GLvfb Top-down bwiZi cwi eZ© nTZ cvti | epÉi `t_©Zv KitZ nte| Gt¶¶t` , YMZ Ges cwi gv YMZ `wó mel qB wetePbvq Avmte|
- cwi gvtci fvgKv mæútkmKj `ti i Rbetji `úó avi Yv `vKtZ nte| cÖZwU `ti cwi gvtci , iæzi Avtvc Kti wLZfvte ti KW©KitZ nte| GB ti KWRZ.Z` wétkl Y Kti cÖZwU mel tq mKj tK Avtív mPZb Kivi ev nevi D` `wM wbtZ nte|

cÖZwmbK gvb Dbqfbi gva`tg wkw¶vi mvgwMK gvb Dbqfbi Rb` wbtgí mel q,tjv mPZbfvte gtb ivLtZ nte :

mPZbZvi t¶¶t

- (K) hvi cwi gvc mæe bq Zvi gvb wqšYl mæe bq;
- (L) tKvb cÖZwvbi gvb cÖZwöZ Kiv Avi gvb wqšY Kiv mæúYwfbæ`vcri | eZgvb RMtZ ÖwqšYi evBtiö etj tKvb K_v biv|
- (M) Dbqfbi c¶uqvq meölg LjR tei KitZ nte AKZKvhZvi KviY| Zvici tmB gj- KviY,tjv wé`iY KitZ nte|
- (N) wkw¶vi gvtbi wba/wvgZvi KviY cwi msL`wmbK c×wZtZ wPwYZ KitZ nte|
- (O) Dbqfbi Rb` GKevi KviY D`Nwub KitZ cri tj Avt`í Avt`í cwi cY©mdj Zv AvbtZ AfbK mæeav nq|

gvb cwi gvc c×wZ

cÖZwvbi Rbej mPZbZvi mæútkwkw¶vi ev cök¶Y jvtfi ci Zv`i cövb KivR nte Dbæ gvtbi wkw¶vi Rb` , YMZ gvbmæúbæcwi Kíbv MhY Kiv| th tKvb cwi Kíbv ev`érvqtb , YMZgvb AR© KitZ ntj cwi gvc AZ`vek`K| Avi AvaybK cwi gvc c¶_exi mKj t`tkB cwi msL`wmbK| Rvcvbx cwi msL`vbwé` l cök¶Kj xMY mvZ (7) aifbi cöké tK¶Kj e`envi Ktib cwi gvtci Rb`| Zviv mst¶¶tc GtK Ö7Qöö bvtg AvL`wqZ Kti tQb|

wewfbæcwi gvc tK¶Kj

cKí ev`érvq l wkw¶vi gvb Dbqfbi GB tK¶Kj Lgy mnvqK etj Gi Dci wétkl , iæzi Avtvc Kiv nq|

wP¶ 2.8-1 : 7Q ev mvZwU tK¶Kj

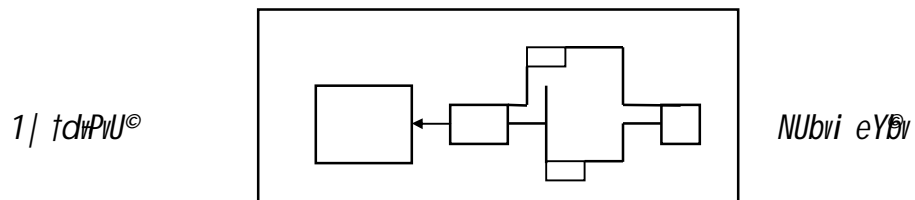

2/ tPKij ÷

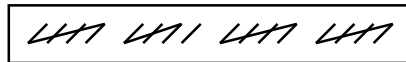

mij DciE msMh I
wekdY tUKwbK|

3/ mt ÷ vMg

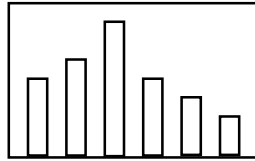

A_en WvqMg

4/ c`tiUv

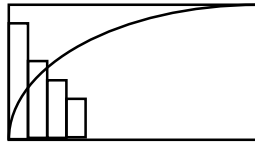

Riwi weiqutK Ab` tjt_tK Avj`v Kiv

5/ vdmterb

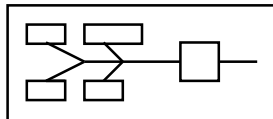

teBb ÷ wgs - mgm`v LtR tei Kivi Rb`

6/ `vUviMg

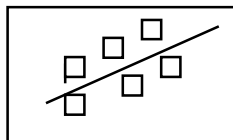

m`uK`vcb

7/ ivbPvU`



gvbUvis -Gi Rb` KtUbj PvU`

mnR c`vZtZ gj`vqb Kitj mKj `ti i tjuKRb ZvonZvno Dcjwä Kti Ges Zvi
djvdj A`i` tbi gta` mKtji wBKU `uó ntq DtV| `f`gqv`x cwi gvc AwZ mntR
A`bK mgm`vi mgvavb t`q| Zvi dtj Kvh`f`iEK e`e`vcbv mnRZi ntq DtV|
wekd`tYi gva`tg mgvavbB w`q`v c`Z`v`bi DbwZi gj- PwvKvW| GLv`b tLqvj,
t`va, GKbvqK `w`f`w/2, c`f`Zgj-K AvPiY cwi Z`R` ntZ nte| c`w`exi wevfbet`tk
MtelYvq t`Lv wM`qtQ Kvh`f`iEK MtelYv axti axti c`Z`v`b`K DbwZi w`tK wbtq hvq|
wKs` Kvh`f`iEK MtelYv memgq GKIKg nte bv| cwi w`vZ e`jS MtelYvi weq`e`
cwi eZ` Kti cwi t`t`ki mvt` wgvj`tg KvR KitZ nte| G MtelYvi mvt` D`v`ebx wP`S`i
fievbr thvM KitZ nte| tkl chS`i AM`v`Z j`q`Yvq nte| Zte gtb ivL`Z nte gvb
Dbq`b ivZviwZ nq bv| Zvi Rb` mg`qi c`q`vRb| cwi gvc I cwi ex`q`Y c`v`Z
avivewnKfvte Pj`tj gvb Dbq`b Aek`B NUte|



cvṫVĒi gj`vqb 2.8

A) eú ubePbx cġæ

mıWK DĒi ubṫ`Rgj-K AḡiıUṫK eĒıvıqZ Kiab | (D`vniY: Avcbvi ubePZ DĒiıU K nṫj GṫK (K) eĒıvıqZ Kiab)

1 | cġZövbi mṫúṫKṁṫPZbZvi cġqvRbxqZvi Kx ?

- (K) mṫPZb e`ı³ıvB ṫKej Dbṫṫbi K_v fıveZ cvṫi
- (L) mṫPZbZvi mKj ṫṫi i Kgıṫ i KıQvKıvQ ubṫq Avṫm
- (M) cġZövṫbi Kıvṫej mṫúṫKṁAŞıṫ Rṫbṫ
- (N) ııvfbam`mṫ`i gṫa` cııı Pq NṫU

2 | ııKḡıvi ṫıMzgvb ARṫbi Rb` meṫPṫq teııK cġqvRb ṫKıvbııi ?

- (K) `ḡı e`e`ıvcbı Kıgııı
- (L) ṫḡsmṫcYṫcııı gıv cıııZ
- (M) ṫbZZı:cġıvṫb cUzcġZövbi cġıvb
- (N) cġZövṫbi `ḡı KgRZPı KıgPııı

Av) msıḡıB DĒi cġæ

1. mṫPZbZvi ṫṫı ṫjv Dṫj - L Kiab |
2. cġKḡıYcöB Rbeṫj i cġıvb KıR Kx?
3. cġZövṫbi DbıZi gj- PııeKııv Kx?

B) iPbıqj-K cġæ

1. mṫPZbZvi avc ṫjv Avṫj vPbv Kiab |
2. ṫQ ṫKŞkj e`ıL`ıv Kiab |

mıWK DĒi :

A) 1 | M 2 | L |

cW 2.9

uk`Ivi gvb vbuDZKiTY ukLb-tkLvfbv Kj vKSkj i Dbqb

[Improving Teaching-Learning Strategies for Quality Assurance in Education]

Df`ik`

G cW tk`I Avicb-

- ukLb-tkLvfbv Kj vKSkj m`utK`Avtj vPbv KiTZ cvi`teb Ges
- tKSkj AvqEjKti cieZx`Z Kvhr`ixf`ite cW Dc`vcb KiTZ cvi`teb|

ukLb I tkLvfbv GKwU w`gla c`uqv| GB c`uqvq uk`IK I uk`Iv_x`Df`iqB RiwZ|
 uk`IK ukLv`teb Avi uk`Iv_x`ukLte Guv ukS` w`gla c`uqv A_`bq| tKvb uk`IKB
 ukLv`TZ cvi`i bv h`w` uk`Iv_x`AvMh` c`Kvk bv Kti | mwZ`Kvi uk`Ivj vf ZLbB nq hLb
 uk`IK-uk`Iv_x`p gta` w`g`v` (interaction) NtU| uk`I`Ki KvR uk`Iv_x`p i Rivri
 AvMh` mw` Kiv, AvMh` a`i ivLv Ges AvMh` Avi cW`vb c`uqv gta` avuk m`uK`
 `vcb Kti Df`vMx I w`teir`Z c`Y uk`Iv_x`Mto tZvj v| uk`Iv j`v`f uk`Iv_x`B g`v`|
 uk`Iv_x`p gb, gvbumKZv, Pwv`v, MhY` IjgZv, aviY`IjgZv I ev`te c`q`v`Mi c`YZv
 t`tL uk`IK cW`v`bi m`y`i I m`y`z`w`itek` Zwi Ki`teb, RiwJ aviY`v`tjvi e`vL`v
 w`tq mnR`eva` Kti Zj`TZ c`uvmx n`teb| GtZB uk`I`Ki KvRi g`v` Df`ik` AfaR
 mwvZ n`te| cW Dc`vcbKv`j` e`wP`gq c`xwZ thgb- e`Zv, AvtjvPbv, c`KvEi,
 mgm`v-mgvavb, c`Kv, MtelY`Mvi, w`Dwiw`-K, c`Kv, Abyk`IY BZ`w`i gva`tg
 uk`IK cW Dc`vcb KiTZ cvi`ib| mKj cvi`Vi Rb` mKj c`xwZ AbyriY KiTZ n`te
 Ggb tKvb aiverav` w`bqg tbB| K_vq etj` O`civ`v`b uk`IKB m`te`Kó..c`xwZ`O`|
 AZGe tKvb cvi`V tKvb c`xwZ e`eniv KiTZ n`te GKRB c`KvYc`B uk`IK Zv mg`K
 Dc`j`w` KiTZ cvi`ib| cvv`K tevamg` Ges mnR Kti uk`Iv_x`p i w`bKU Dc`vc`bi
 Rb` uk`IK bvbv ai`bi tKSkj i AeZviYv Ki`teb| ukLb-uk`IY c`xwZ n`te e`w`
 w`bi`c`I Ges tg`w`j K| c`xwZ`K Kvhr`ix Kivi Rb` uk`IK bvbv ai`bi tKSkj Ae`j`
 Kti `v`Kb| tKSkj e`w`m`v`c`I w`elq| GKB w`elq Dc`vcb KiTZ w`m`tq w`w`fb`w`K`IK
 w`w`fb`v`te Dc`vcb Kti `v`Kb| uk`I`Ki Ziv`Iw`YK ey`g`E`v, c`xwZ I tKSkj i Avb,
 cvi`tek, w`elq`i Avb m`w`KQycv Dc`vc`b KvR j`v`M| uk`Iv_x`p i w`bKU w`elq`
 mnR`eva` I u`q`g Kti tZvj vi Rb` uk`IK e`vL`v, eY`Bv, Mv, c`KvR`Avmv, msw`IjB
 w`j`w`LZ D`Ei, Dc`KiTY e`eniv BZ`w`i bvbv`w`ea tKSkj c`q`v`M KiTZ cvi`ib| tKSkj i
 c`q`v`M w`b`f`P Kti uk`I`Ki uk`Iv`MZ I e`w`MZ `w`kó` Ges kv`w`i K I gvbumK mv`g`
 I ey`x`MZ w`P`S`f`ivebv Ges w`w`fb`w`c`q`v`M`K w` K I Aw`F`AZvi Dci |

cW Dc`vc`bi c`te`uk`I`Ki KZ`v`jv tgw` g ev bwiZi K_vl tLqj ivL`TZ nq|
 thgb- mnR t`tK RiwJ, gZ`t`tK w`egZ`v` Rivbv t`tK ARivbv, w`t`kl t`tK mvariY,
 w`t`kd`Y t`tK m`st`kd`Y BZ`w`i | GKRB uk`I`Ki thgb w`elq`e`i Dci `Lj `v`K`TZ



Povšigj-ʔqb- 2

A) eú iʔeʔbɔ cʔæ

mʔWK DĒi iʔ ʔgʔ-K Aʔi i uʔK eʔvʔqZ Ki ab | (D`vni Y: Avcbvi iʔeʔPZ DĒi uʔ K nʔj GʔK eʔvʔqZ Ki ab)

- 1/ DʔP gʔʔbi ci vʔkʔP Kiv Kx?
 - (K) iʔ ʔi vʔ i c_ iʔ ʔbvi ʔ i qv
 - (L) iʔ ʔvi gʔʔbi iʔvʔvʔbZv cʔZʔi va Kiv
 - (M) cʔvmKʔ i mʔWK cʔ_ cʔi Pj bvi Kiv
 - (N) iʔ ʔKʔ i cʔv iʔbi ʔ ʔZv eviʔbvi
- 2/ iʔmve iʔixʔʔyi cʔqʔRbʔqZv Kx?
 - (K) Aa ʔʔ / cʔi Pj KʔK A_ ʔel ʔq mZKʔvLv
 - (L) AcPq ʔi vʔai gva ʔg iʔ ʔvi gvb Dbʔb
 - (M) iʔ ʔvi cʔZʔvʔbʔK mPj i vLv
 - (N) iʔ ʔvi cʔZʔvʔbvi mʔvʔg iʔWK i vLv
- 3/ Dbʔb cʔvʔqʔ mKʔj i gʔʔS mʔiʔ Avʔm iʔKʔiʔe ?
 - (K) mKj ʔK ʔʔ iʔbi mʔb DrmʔvʔZ Kʔi
 - (L) Dbʔb cʔvʔqʔ mKj ʔK mʔvʔʔ Kʔi
 - (M) APj ve ʔvi gʔ- Kvi Y LʔR ʔei Kʔi
 - (N) iʔ Kʔbʔ ʔbʔvʔgʔ-K ci vʔkʔʔvʔbi gva ʔg
- 4/ ʔbZʔZʔi ʔʔgZvʔqb Kx ?
 - (K) ʔbZvi LʔkʔgZ ʔʔgZv cʔqʔM Ki ʔZ cʔiv
 - (L) ci vʔkʔʔʔg ʔbZvi ʔʔgZv cʔqʔM Ki ʔZ cʔiv
 - (M) ʔhʔvʔʔKʔiʔe ʔbZvi ʔʔgZv cʔqʔM Ki ʔZ cʔiv
 - (N) Aa ʔbʔ i Kʔvvi kvʔʔbi gʔa ʔ i vLv

Av) mʔiʔʔB DĒi cʔæ

1. iʔ ʔvi gvb Dbʔʔb ʔ ʔ iʔi cʔqʔRbʔqZv Kx ?
2. cʔZʔvʔbi mʔvj ʔ Bʔvʔvʔm Kx Kx iʔel q_ vKv cʔqʔRb ?
3. iʔ ʔvi gvb Dbʔʔb Kx Kx iʔel q iʔeʔPbʔq i vLʔZ nq ?
4. ʔj xq iʔmʔvʔʔʔej ʔZ Kx ʔei Svq ?

B) iʔbʔvʔgʔ-K cʔæ

1. avi veʔvʔK gvb Dbʔb cʔPʔv Ae ʔvʔZ i vLv i Dcʔvʔmgʔ Avʔj vPbv Ki ab |
2. iʔ ʔvi gvb Dbʔʔb cʔZʔvʔbi ʔj bʔ ʔbi iʔbi xʔʔʔyi cʔqʔRbʔqZv Avʔj vPbv Ki ab |
3. iʔ ʔvi gvb Dbʔʔb iʔeʔvʔbʔKʔʔkj cʔqʔvʔMi cʔqʔRbʔqZv Dʔj L Kʔi gvb Dbʔb ʔKʔʔkj ʔj v Avʔj vPbv Ki ab |
4. iʔ ʔvi cʔZʔvʔbi APj ve ʔvi iʔKʔiʔe iʔbi fʔY Kiv hvq?
5. Avq-e ʔʔqi iʔmʔvʔʔei gʔ-bʔvʔZ ʔj v Avʔj vPbv Ki ab |

mʔWK DĒi : A) 1/ M 2/ L 3/ L 4/ M |

cW 3.1

Kgm̄úv`b gj`vqb : avi Yv, Zvrch, Dfík` I bñZgvj v

[Performance Appraisal : Definition, Significance, Goals and Principles]

Dfík`

GB cW tkfI Avcib –

- Kgm̄úv`b gj`vqtb A_`e`vL`v KitZ cvi`teb ;
- ukŷfíkI Kgm̄úv`b gj`vqtb Zvrch`etk- IY KitZ cvi`teb;
- Kgm̄úv`b gj`vqtb Dfík` weZ KitZ cvi`teb Ges
- G tŷfÍ AbŷZe` bñZgvj v, tj v Dfík` KitZ cvi`teb|

**Kgm̄úv`b
gj`vqtb avi Yv**

mavi Yfite Kgm̄úv`b gj`vqb ejtZ eSvq tKvb cŷZv`tb KgPZ KgRZP, KgPvix`i Dci AvbŷmbKfite AwcZ ubw`ŷ`vqZ; I KZ` ukfite m̄úv` Z nŷ`Q Zv ubifcY ev gj`vqb Kiv| cŷZv`tb Kgm̄úv`b gj`vqb avivemKfite ev ubw`ŷ` mgq Ašli nŷ` cti| Avgrv`i t`fk miKwi cŷZv`tb cPw`j Z eml`R tMvcbxq cŷZv`tb cŷv`b Kgm̄úv`b gj`vqtb B GKw cŷv`qv| Kg`ŷZvi gj`vqtb wefbae t`fk wefbaemMVtb wefbaec`wZ cPw`j Z itq`Q| cŷ`Kg`ŷZvi gj`vqb cŷv`mbK cŷv`qv GKw ubqšYgj-K nñZqv`i wntmte t`Lv nZ Ges Zv wj gj`Z EaŷZb KgRZPKZ`R Aaxb` KgPvix`i KvhŷŷZvi hvPvB| ukS`eZŷv`b G avi Yvi m̄úv`vi Y I weKv` NŷUŷQ| AvaybK mSMVtb Kgm̄úv`b gj`vqb nŷ`Q KZUv KvhRixfite KgŷfÍ e`w`Zvi Dci AwcZ Kgm̄úv`b KitZ Zvi avivemK gj`vqb| AvaybK Kgm̄úv`b gj`vqb e`w`Zvi Pwv`fK I e`w`MZ , Yvewj i gvb hvPvBtq mxgve`tbB, eis Gi Kvr nŷ`Q mSMVtb Dfík`i w`f`EŷZ tmLv`tb wbtq`wRZ e`w`Zvi KvhŷŷZvi hvPvB Ges tm Abŷvqx f`iel`Z Kgm̄úv`b cŷv`qv , YMZ gv`bv`qtb Dciq D`w`eb| Gw mSMVtb Kgm̄úv`b mej I `ŷŷ w`K, tj v hvPvBceR Zvi w`f`EŷZ gv`vZ w`i Kti Kgm̄úv`b gv`bv`qtb GKw KvhRi cŷv`qv wntmte e`eüZ nq| cŷZcŷŷ KvhŷŷZvi gj`vqb nŷ`Q GKw cŷZv`tb ev mSMVtb gv`bem`út`i h_v_`e`envi I Dbqtb GKw cŷv`qv| GŷZ mSMVtb thgb weKv` nq tZgwb KgRZP I KgPvix`i gv`bv`qtb nŷ`_v`K|

ukŷfíkI Kgm̄úv`b gj`vqtb Zvrch`

ukŷfíkI Kgm̄úv`b gj`vqb cŷv`qv BwZv`m m̄v`N`bv nŷ` I eZŷv`b mg`q Gw GKw cŷv`qvRbxq Kvr wntmte t`Lv w`ŷ`Q| th tKvb ukŷv` cŷZv`tb, tñvK Zv miKwi ev temiKwi, ukŷfíkI Kgm̄úv`b gj`vqtb , iaz; Acwi mxg| KviY Gi gra`tgB we`vj`ŷ`q ukŷKMY tKgb `vqZ; cij b Ktib, D` KvtRi Rb` tK KZLwb thvM, Zv`i KvtR Kx Kx mgm`v itq`Q, ukŷfíkI KgŷŷZvi ùj`ŷi j`ŷŷ` Kx e`e`v MpxZ nI qv cŷv`qvRb BZ`w` m̄úv`K`Aew`Z nŷ`q Zv`i tckvMZ gv`bv`qtb w`K wbt`Rbv j`v`f` Kiv m̄e` nq| Gfite Kgm̄úv`b gj`vqb ukŷfíkI tckvMZ weKv`tki Drm`v` m̄v` I mŷh`M cŷv`tb gv`tg Zv`i Kg`Póvi wbf`ŷh`M`Zv ew`ŷZ mñv`qK nq| e`Z ukŷfíkI Kgm̄úv`b gj`vqb Qvov ukŷv` e`e`vq wbtq`wRZ ukŷKe,` ukŷvi j`ŷŷ` I

Kgŷu`b gj`iqb Avevi KLbI Avgj vZmŠK ev tckvMZ Dbq̄b Gi th tKvbuU A_ev Dfq Df`tk` cwi Pwv Z nŷZ cvti | Avevi KLbI Zv nŷZ cvti MVbgj-K (formative) ev cŷŠK (summative) |

**weŷ`kx MŷeIYv
cŷZte`b**

DĒi Avtgvi Kvi ACAS, 1986 MŷeIYv cŷZte`b wkŷŷKi Kgŷu`b gj`iq̄bi Df`tk` , tj v ubgŷc wPwvZ Kiv nŷZtQ :

1. wkŷŷKf`i `wqZj Acŷbi cwi Kíbv cŷq̄b Ges Zŷi i thvM`Zvi gj`iq̄b;
2. Pvkwi Kvj xb cŷkŷŷY wkŷŷKf`i AskMŷY mŷuMŷZ cwi Kíbv cŷq̄b;
3. wkŷŷKf`i tckvMZ weKivK Ges fweI`Z Pvkwi i DbwZwearb;
4. wkŷŷKf`i tckvMZ Dbq̄bi mŷtebv wPwvZKiv Ges h_vh_ Pvkwi Kvj xb cŷkŷŷY AvŷqvRtbi gva`tg Zv cwi ciŷY mnvqZvKiY;
5. th mKj wkŷŷKi Kgŷu`b tbi tŷŷŷI mgm`v ev NvUwZ itq̄tQ Zv wPwvZ Kiv Ges cŷqvRbxq wŷŷ`Rbv, civgk`I cŷkŷŷYi gva`tg Zv mgvavt̄b mnvnh` Kiv | k;Ljvgj-K e`e`v MŷYŷK GŷŷŷI c_wKfivte ivLv DvPZ | Zte gj`iq̄b cŷB cŷ_wgK ti KŷWŷ wŷŷŷZ Zv cŷqvM̄i cŷqvRb nŷZ cvti Ges
6. wkŷŷK wŷŷqvM cŷqv̄i mŷŷ_ mŷwŷ e`w`eMŷK Kgŷu`b gj`iq̄b cŷqv̄i weŷfbae w`K mŷŷŷK`AewZKiv |

hŷivŷR`i Cambridge Institute of Education Survey KZŷ 1989 mŷŷ cwi Pwv Z KŷqKvU mgvŷŷvq cŷB wkŷŷK Kgŷu`b gj`iq̄bi Df`tk` , tj v nj :

- wkŷŷKf`i tckvMZ Pwv`v wbiŷY;
- wkŷŷKf`i fvgKvi cwi eZŷ I mŷŷvab;
- wkŷŷv cŷZŷv̄bi mŷŷ_ wkŷŷKf`i tckvMZ mŷŷŷKŷ Dbq̄b;
- wkŷŷK I wkŷŷv cŷZŷv̄bi Df`tk`i gŷa` mŷwZ `vcb, Dbq̄b I mvgŷm` wearb;
- wkŷŷv cŷZŷv̄bi Dbq̄b wkŷŷKi gZvgZ cŷvŷki mŷŷvM cŷvb hvŷZ G , tj v h_vmgŷq weŷewPZ nq ;
- wkŷŷKf`i Kgŷŷv̄bi Dbq̄bi j ŷŷ` Zvŷi mŷŷ mŷtebv wPwvZKiv;
- wkŷŷKf`i Kgŷu`b t̄b tKvb mgm`v_vKŷ Zv wPwvZ Kiv Ges mgvavt̄b mnvnh` Kiv;
- wkŷŷKi AZvZ KgŷŷZvi gj`iq̄b Ges fweI`Z KgŷŷZvi Dbq̄b;
- wkŷŷv cŷZŷv̄bi Dbq̄b Ges
- wkŷŷKi KgŷŷZv Z_v AvfŷZv I `ŷŷZvi Dbq̄b |

Kgŷu`b gj`iq̄b mŷuMŷZ Avil weŷfbae gZvgZ itq̄tQ | Zte tgvUvgvŷvte Dcwiŷj - wLZ , tj vB nj th tKvb MVbgj-K Ges mnŷhwmZvgj-K gj`iq̄bi Df`tk` | wkŷŷvcŷZŷv̄bi gŷa` thvMŷŷv̄Mi Dbq̄b Ges wkŷŷKŷK cŷqvRbxq djveZŷ (feedback), mnŷhwmZv I DŷŷKivŷi GKvU Ab`Zg Dcvq nj wkŷŷKf`i GB

Kgᚖúv`b gj`iqb| G cūqv t`tk ᚖK, ᚖKᚖᚖx`Zᚖ ᚖKᚖᚖ cūZōv`b Dbq̄b m`úKZ mýúó ᚖK ᚖb`Rbv ARB m`e| Zte Gt̄t̄i D̄tj-L` th, ᚖKᚖt̄Ki Kgᚖúv`b gj`iqbtK tb̄ZevPK Aᚖᚖᚖ t`tL B̄ZevPK AᚖᚖᚖetePbv Ki`Z n̄e|

Kgᚖúv`b gj`iqt̄bi b̄mZgvj v

Dc̄ti Avt̄j vPbv mýúó th, ᚖKᚖt̄Ki KgᚖᚖZvi gj`iqt̄bi ᚖefbaeD̄t̄i k` i`t̄q̄Q| KgᚖᚖZvi gj`iqb Avevi ᚖefbaeᚖte n̄Z c̄ti hv gj`Z KgᚖᚖZvi gj`iqt̄bi D̄t̄i k`i Dci ᚖbfP K̄ti| Zte Kgᚖᚖúv`b gj`iqt̄bi t̄t̄i K̄QybmZgvj v Ab̄yZ n̄lqv evĀbxq hv Kgᚖᚖúv`b gj`iqt̄bi K̄vR̄ix ev`evq̄b m̄vqK n̄e| Nuttall (1986), Conley (1987), ACAS (1988) Kgᚖᚖúv`b gj`iqt̄bi tek̄K̄QybmZgvj v m̄z̄m̄i k̄ K̄t̄i Q̄b h̄vi m̄i m̄st̄t̄c ᚖb̄t̄P D̄t̄j L̄ K̄iv n̄j | Kgᚖᚖúv`b gj`iqb m̄s̄m̄s̄i th t̄K̄v c̄m̄i K̄i bv c̄ᚖq̄b I ev`evq̄b Gᚖᚖᚖ ᚖefevPZ n̄Z c̄ti |

**ᚖKᚖt̄Ki Kgᚖᚖúv`b
gj`iqt̄b Ab̄yZe`
b̄mZgvj v**

1. Kgᚖᚖúv`b gj`iqb cūqv i cūZ mK̄t̄i m`ᚖb I cūZk̄m̄ ᚖK̄t̄Z n̄e| tmB m̄t̄_ GB c̄m̄i K̄i bv c̄ᚖq̄b I ev`evq̄b m̄t̄_ m̄s̄i k̄ó e`ᚖᚖᚖ i cūZ Av`ᚖ ᚖK̄t̄Z n̄e| A`P̄ Zv mK̄j Ask̄M̄h̄YK̄vixi K̄v̄Q̄ M̄h̄Yth̄vM̄` n̄e|
2. gj`iqb c̄m̄i K̄i bv c̄ᚖq̄b mK̄j Av̄M̄h̄x e`ᚖᚖᚖ ev`ᚖᚖ i m̄t̄_ Av̄j vc-Avt̄j vPbv Ki`Z n̄e Ges Zᚖᚖ` i`K̄ c̄ᚖq̄RbgZ G K̄v̄R̄ m`úᚖᚖᚖ Ki`Z n̄e|
3. gj`iqb c̄m̄i K̄i b̄m̄J n̄e Dbq̄bḡj-K, MVbḡj-K Ges B̄ZevPK|
4. gj`iqt̄b R̄m̄Z e`ᚖᚖᚖt̄M̄P̄ Dch̄ᚖ c̄K̄ᚖᚖY ᚖb̄w̄Z̄ Ki`Z n̄e|
5. Kgᚖᚖúv`b gj`iqb m`úᚖᚖK̄h̄v` i av̄i Yv i`t̄q̄Q Zᚖᚖ` i ᚖv̄iv gj`iqb K̄iv̄Z n̄e|
6. ᚖKᚖᚖK̄t̄ i t̄K̄ej gj`iqb c̄m̄i K̄i bv c̄ᚖq̄t̄bi m̄t̄_ R̄m̄Z Ki`t̄j B̄ n̄e bv, tmB m̄t̄_ e`eūZ gj`iqb %k̄ó` Ges t̄K̄v t̄K̄v ᚖel t̄q̄ gj`iqb n̄e tm̄ e`v̄c̄ti I ᚖKᚖᚖK̄t̄ i m̄t̄_ Avt̄j vPbv Ki`Z n̄e|
7. gj`iqb cūqv̄m̄J n̄e ᚖᚖᚖᚖ| A`P̄ Ḡt̄Z gj`iqbK̄vix (appraiser) Ges gj`iqK̄ (appraisee) D̄f̄t̄q̄i B̄ K̄ᚖ ej̄vi I t̄k̄v̄v̄i m̄ᚖh̄v̄M̄ ᚖK̄t̄Z n̄e| GQ̄vov gj`iqb m̄s̄i k̄ó ᚖKᚖᚖ cūZōv`b P̄v̄v̄ᚖi m̄t̄_ m̄ᚖᚖZc̄ᚖᚖᚖ Ges h̄v̄K̄ A`P̄ th ᚖKᚖᚖK̄t̄K̄ gj`iqb K̄iv n̄e Z̄v̄i ᚖefbaeᚖᚖᚖ i Dbq̄bt̄K̄ c̄l̄v̄b` ᚖ`Z n̄e|
8. gj`iqb n̄e av̄i vev̄n̄K Ges c̄x̄m̄Zm̄ᚖZ̄|
9. gj`iqt̄b ᚖefbae i`b̄i t̄K̄sk̄j Ab̄yZ n̄e|
10. Kgᚖᚖúv`b gj`iqt̄b cūB̄ dj̄v̄d̄t̄j i ᚖf̄v̄ᚖ̄Z̄ K̄v̄h̄R̄ix e`e`v̄ M̄p̄v̄Z̄ n̄Z n̄e|

m̄st̄t̄c Kgᚖᚖúv`b gj`iqb cūqv̄t̄K̄ m̄ᚖᚖᚖ Ki`Z n̄j Zv̄ n̄Z n̄e D̄t̄i k̄ᚖf̄v̄ᚖK, mr, MVbḡj-K, ᚖb̄f̄ᚖ̄th̄v̄M̄, ᚖᚖᚖᚖ, Dbq̄bḡj-K, dj̄c̄h̄, ev`ᚖᚖᚖᚖ Ges Ab̄ᚖc̄ᚖ Yv̄j-K|

eZᚖᚖᚖ c̄v̄V Av̄ḡiv Kgᚖᚖúv`b gj`iqt̄bi A`ᚖᚖᚖᚖ Kgᚖᚖúv`b gj`iqt̄bi Z̄v̄rch̄ᚖ D̄t̄i k̄` Ges G m`úᚖᚖᚖ b̄m̄Zgvj v ᚖel t̄q̄ Aēm̄Z n̄j v̄ḡ| Gi ᚖv̄a`t̄g Av̄R̄Z Āv̄b cūZōv`b Dbq̄t̄b GK̄v̄ Dch̄ᚖ Kgᚖᚖúv`b gj`iqb K̄v̄h̄ᚖᚖᚖ M̄h̄ᚖY D̄ᚖᚖᚖK̄i`Yi c̄īk̄v̄c̄m̄k̄ Gi m̄ᚖᚖK̄ I K̄v̄h̄R̄ix ev`ᚖᚖᚖᚖ ᚖK̄ ᚖb̄`R̄bv cūᚖᚖ K̄i`te| cieZ̄ᚖᚖᚖ Av̄ḡiv ᚖKᚖᚖᚖᚖ gj`iqt̄bi ᚖefbaeᚖᚖᚖ m̄ᚖᚖᚖK̄ Aēm̄Z n̄e|



eiVvEi gj`vqb 3.1

A) msrjB DEi ckae

1. Kgmuv` b gj`vqb ej tZ Kx eSvq ?
2. ikqtki Kgmuv` b gj`vqb , iaZcYqKb ?
3. ikqtki Kgmuv` b gj`vqbi mglj Kx ?
4. Wise Ges Ab`v`i gtZ Kgmuv` b gj`vqbi Dtk` Kx ?
5. MZvbMvZK At`Kgmuv` b gj`vqbi Dtk` weeZ Kiab|
6. ikqk Kgmuv` b gj`vqbtK BvZevPK At`Lr DvPZ tKb- G mvtKAvcbri
AvfgZ mstqtc vj Lj|

Av) iPbvj-K ckae

1. ikqk Kgmuv` b gj`vqbi Dtk` eYv Kiab|
2. ikqk Kgmuv` b gj`vqtb AvyZe` bmvZgvj v Dvj L Kiab| eijs v` tki cPvj Z
ikqv e`e`vq Zv KZUv AvyZ nt`Q tm mvtKvGKvU mgvtj vPbvj-K cEÜ vj Lj|

GiU Kgmúv`b gj`vqtbí cŕwZgj-K`fi | G cte°gj`vqb mæútk°msukó e`w³etMP gta` mtpZbZv mŷó Kiv nq| GQovon gj`vqb mæúwKŒ weifbæ KgrvU mŷZvte cwiPvj bvi`_t_°wKŒv cŕZŕvbi wfZti I evBti msukó e`w³etMP Rb` cŕKŒY AvtqvrB G chŒqi KivR| G`fi mæúw Ze` KgrvU Pvi fvtM wef³| G, tjv nj -

**cŕwZ`fi
mæúw Ze` KgrvU**

- ◆ cwi tek mŷó I cŕwZ (climate setting and preparation)
- ◆ mæúw°cŕZŕvbi chŒj vPbv (whole institution review)
- ◆ gj`vqtbí gvb`U wbaŒ Y (fixation of criteria for appraisal)
- ◆ weifbæDrm t`tk DcvE mSMŒ (data gathering from different sources)

**Kgmúv`b
gj`vqtbí cwi tek
mŷó**

cwi tek mŷó I cŕwZt GiU cwi Kíbv chŒqi GKwU , iæZcY°KivR| wKŒv cŕZŕvbi wKŒK KZŒ Kgmúv`b gj`vqtbí h_vh_ cwi tek I cŕwZ AvtQ wK bv Zv G chŒq hvPvB Kiv nq| wKŒv cŕZŕvbi Kgmúv`b gj`vqtbí Rb` cŕqvRbxq mæú` AvtQ wK bv; Gi wKŒKe,` Kgmúv`b gj`vqtbí mnvqZv Kite wK bv; ÷vd ev wKŒKeŒ`i gj`vqb cŕµqvq AskMŒtiYi`ŒZv AvtQ wK bv; wKŒv cŕZŕvbi wKŒKe,` gj`vqb djvdj tgŒb wŒZ cŕZ wK bv; wKŒv cŕZŕvbi wKŒK Kgmúv`b gj`vqtbí gŒbvfe itqŒQ wKbv BZ`w i DciB wbfP Kti Kgmúv`b gj`vqtbí cwi tek mŷó| hŒ wKŒv cŕZŕvbi Gme`ewkó`_tj vi AbŒw`wZ`_vtK Zte cwi tek mŷó Rb` wKŒv mgq e`q I cŕqvRbxq DŒ`wM MŒY Kitz nte|

**cŕZŕvbi tcŒvU
cŕwZ I Pwv`v
chŒj vPbv**

mæúw°cŕZŕvbi chŒj vPbv th tKvb gj`vqb cwi Kíbv cŒvqtbí cte° AvtiKwU cŕwZgj-K KivR cŕqvRb| Avi Zv nj mæúw°wKŒv cŕZŕvbi chŒj vPbv| GiU gj`Z wKŒv cŕZŕvbi AvZŒgj`vqb hv wKŒv cŕZŕvbi Kti`_vtK| G aitbi gj`vqb wZbvU DŒik`ciY Kti, cŕgZ : GiU wKŒv cŕZŕvbi Kgmúv`b gj`vqtbí tcŒvU`Zwi Kti, hvi dtj wKŒKe,` gj`vqb cŕµqv mŒ_ GKivŒ nŒZ cvŒb; wZxqZ: GiU gj`vqtbí Rb` wKŒv cŕZŕvbi cŕwZ evovZ cvŒi Ges ZZxqZ: wKŒv cŕZŕvbi chŒj vPbv cŕB djvdj tk gj` Kgmúv`b gj`vqtbí cŕB djvdj i mŒ_ mæú,³ Kti wKŒv cŕZŕvbi DbqŒb AwKZi KvŒix tKŒkj wPwY Z Kiv thŒZ cvŒi |

**gj`vqtbí gvb`U
wbaŒ Y**

gj`vqtbí gvb`U wbaŒ Yt th tKvb gj`vqb cŕµqv GKwU Acwivh°cŒenj Kx bŒwZgjv ev gvb`ŒUi wŒEŒZ gj`vqb Kiv nte| G cŕkæ Dci wŒE KtiB wePri Kiv nte th wKŒŒKi Kgmúv`Œbi j ŒgŒv KZUv AwRŒ nŒqŒQ| cŕwZ chŒq gj`vqtbí gvb`U wbaŒ Z nŒj gj` Kgmúv`b gj`vqb cŕµqv ZvŒZ , iæj; t`l qv mæe nte| wKŒKe,` I G mæútk°AewZ nŒq tm AwfgŒ Kgmúv`Œb DŒ`wMx nteb| GQovon GiU gj`vqb cŕµqvK DŒik`gŒx Kite|

**gj`vqtbí gvb`ŒUi
Drm**

gj`vqtbí gvb`U wbaŒ ŒYi weifbæDcvq I Drm itqŒQ| Zte gj`vqtbí gvb`U wbaŒ ŒY wKŒvi j Œ` I DŒik`, wKŒv I wKŒv`vb mæúwKŒ weifbæ MŒelYv, gŒbweAvŒbi weifbæZÉ; I AwfÁZvtK wŒE wŒmŒe weŒPbv Kitz nte| gvb`U , tjv wKŒvi j Œ` ARŒ, wKŒv`vb cŕµqv, wKŒŒKi Kgmúv`b, ARŒ, Drcv` (outcome) BZ`w mæúwKŒ nŒZ nte| Kgmúv`b gj`vqtbí gvb`U wbaŒ ŒY tKvb wŒlq , tjvtK , iæj; t`l qv DŒPZ tm mæútk°cieZŒŒ Avgiv Avi I we`Zfvte Rvbe| Zte gvb`U wbaŒ Z nŒ qvi ci Zv gj`vqb cŕµqv cŕZŒw`fi AbŒZ nŒZ nte|

neufbæDrM t_ᚲK DcvĒ msMāt GūU Kgm̃uúv`b gj-`iqb cūᚲqvi cwi Kíbv chᚲqí Avᚲi KūU iæZcY©KivR| tckvMZ gj-`iqb cūᚲqvi Ab`Zg cāvb KivRB nj DcvĒ msMā Ges cūB DcvĒĒi wfiĒtZ tckvMZ Dbqᚲbi e`e`vKiY| DcvĒ msMāni Ab`Zg cāvb Dcvq chᚲeᚲY| GŌvon DcvĒĒi AvīI neufbæDrM itqᚲŌ, hv m̃uúK©Avcbviv cieZix©civV AewNZ nᚲeb| Zᚲe thfvᚲeB DcvĒ msM̃pxZ trivK bv tKb DcvĒ msMāKivY c̃x̃wZ nᚲZ nᚲe MVbgj-K (formative) Ges mnivqZvgj-K| gj-`iqbKvix Ges gj-`iqᚲKi cūᚲg mfvᚲZB ᚲbaᚲY Kitz nᚲe tKiv aiᚲbi DcvĒ msMā Kiv nᚲe, tKiv t_ᚲK nᚲe Ges tKiv c̃x̃wZ nᚲe| GŌvon DcvĒ msMāni b̃wZ I c̃x̃wZ m̃uúKᚲ code of conduct DcvĒ msMāni tᚲᚲĀ AbjñitYi e`e`v_KtZ nᚲe|

2. Kgm̃uúv`b gj-`iqb mᚲᚲivKvi

mᚲᚲivKvi nᚲ`Ō Kgm̃uúv`b gj-`iqb cūᚲqvi gj- Dcvq| GūU GK aiᚲbi tckṽuúKᚲ Avᚲj vPbv hv m̃vavi Y mᚲᚲivKviti i ᚲᚲᚲ e`vck Aᚲ_`e`eüZ nq| ᚲᚲᚲᚲKi Kgm̃uúv`b gj-`iqb cūᚲqvi AZ`vek`Kiq Ges eva`Zvgj-K Ask nᚲ`Ō GB mᚲᚲivKvi | cūᚲZ cᚲe msM̃pxZ Z` I DcvᚲĒi Dci wfiĒ Kᚲi GB gj-`iqb mᚲᚲivKvi MāY Kiv nq| G chᚲq m̃vavi YZ hv Kiv nq Zv nj -

gj-`iqb mᚲᚲivKviti KiYᚲq ũelq

- ceᚲZix©gj-`iqb t_ᚲK G hverKiv msNūUZ Kgr̃vŪ Ges AᚲRᚲ m̃vᚲᚲj`i chᚲj vPbv|
- f̃uel`r Kivhᚲjvᚲci Rb` tckvMZ j ᚲᚲᚲᚲv ᚲbaᚲY| Zᚲe GB j ᚲᚲᚲᚲv nᚲZ nᚲe m̃ᚲᚲ ̃, cwi gvcᚲh̃M, ARᚲᚲh̃M, ev`b̃agxᚲGes mgqwf̃ĒK|
- Dbqᚲ Ges cūᚲᚲᚲY P̃nn`v ᚲbiᚲcY|
- ᚲbaᚲi Z j ᚲᚲ` ARᚲᚲbi Dcvq ᚲbaᚲY Ges G, ᚲj v m̃uúv`ᚲbi b̃wZvgj v ᚲbaᚲY|
- gj-`iqᚲbi tiKWᚲp̃ṽšKiY|

mᚲᚲivKvi gj-`iqbKvix (appraiser) Ges gj-`iqᚲKi(appraisee) gᚲa` tckvMZ cūᚲqRbxq Avjvc-Avᚲj vPbvi m̃ᚲᚲh̃M m̃ᚲᚲ Kᚲi | AZGe GūU ᚲbq̃gZ Ges tKivbiKg evav-ũeciĒ Ōvon AbjñZ ñlq cūᚲqRb| G aiᚲbi mᚲᚲivKviti AvᚲqvRb ᚲᚲᚲᚲv cūᚲZōvb Ōᚲᚲi ᚲᚲᚲ Kiᚲj ᚲij nq| G chᚲq ᚲᚲᚲᚲKi tckv I PvKix m̃uúK©m̃x̃ṽšI f̃uel`Z tckvMZ Dbqᚲbi Dᚲ`vM t̃blqv nq etj G chᚲqū tek`ũᚲR̃vZi| Kgm̃uúv`b mᚲᚲivKviti ᚲᚲᚲᚲvᚲbi cwi Kíbv I cūᚲZ, tᚲYxKᚲ chᚲeᚲY, ᚲᚲᚲᚲvᚲbi ᚲᚲᚲZv Ges G, ᚲj vi cvi`ũᚲi K m̃uúK©BZ`w` w`K, ᚲj vᚲZ iæZjw`ᚲZ nᚲe|

Kgm̃uúv`b gj-`iqb mᚲᚲivKviti i Bm̃y

Kgm̃uúv`b gj-`iqb mᚲᚲivKvi ms̃ᚲᚲ Ggb ᚲKŌyBm̃y itqᚲŌ hv AᚲbK mgq c̃jiv gj-`iqb ᚲᚲᚲK e`_Kᚲi ᚲᚲZ ev j ᚲᚲ` ARᚲᚲK e`ṽnZ Kitz cvᚲi | t`ũbs Ges t`ũbs (Stenning & Stenning, 1984) Gi gᚲZ, G aiᚲbi ᚲZbū Bm̃ynj -

gj-`iqbKvixi cūᚲᚲᚲYi Af̃ve

cūᚲgZ: AᚲbK mgq gj-`iqbKvixi cūᚲqRbxq cūᚲᚲᚲYi Af̃vᚲe gj-`iqb mᚲᚲivKviti DᚲĀk` ARᚲ e`ṽnZ nq|

**gj`vqbKvixi
gtbMZ mgm`v**

WZiqZ: gj`vqbKvixi KZ, tjv gtbMZ mgm`v gj`vqtb i`be⁹³KZvK AtbK mgq
úgukMŵ' Kti | G aitbi mgm`v, tjv nj Hallow Effect, Constant Error,
Contrast and Similarity Error, Logical Rating Error BZ`w | cieZr⁹citV
(3.4) G mKj gtbv%ÁvibK mgm`v, tjv m⁹útk⁹Avtj vPbv Kiv ntqQ |

**AcŵqvRbxq iel t q
i aZj**

ZZiqZ: AtbK mgq gj`vqbKvix Ges gj`vqK AcŵZKi NUbv I AbŷvZ Govtbvi
Rb` cKZ.mgm`v ev` w` t q AcŵqvRbxq iel q wbtq Avtj vPbv Kti b |

Kgŵúv`b gj`vqb mvŷvrvKvi m⁹útkZ Bmŷev mgm`v, tjv ev`é tPrtL t`Lv mtÉj | Gi
tKvb weKí tbB | AZGe GtK wKfvte j ŷŷwfglyx I dj cŵ-Kiv hvq tm iel t q tRvi
w` tZ nte | wefbaŵteI Yvq cŵB dj v dj t`tK Rvbn hvq th, mvŷvrvKvi c⁹úzi mvdj`
wbfP Kti wbgw ŵLZ kZŷej i Dci |

**gj`vqb mvŷvrvKvi
mdj Zvi kZŷej**

- ◆ mvŷvrvKvi cŵvbKvix I mvŷvrvKvi MŵYKvixi cvi`úwi K Av`v I mnvbfvZ ;
- ◆ Dftqi`wófwzi mgšqmvab Ges cvi`úwi K GKvZvZvteva ;
- ◆ tKvb Abwf⁹cZ AvPi⁹Yi Rb` mivmwi KvD⁹K t`vIv⁹ic bv Kti Zvi Kvi Y
AbŷvÚvb Ges f⁹z⁹aw` t`Kivi Dcvq m⁹útk⁹civgk⁹cŵvb ;
- ◆ mvŷvrvKvi cŵvbKvixi Dci tRvi Kti wbtRi gZvqZ Pwictq bv t`I qv ;
- ◆ Dfq ctŷji AskMŵtY Ges cvi`úwi K`t`P cŵZ`wó ti tL j ŷŷ wbaŷ Y ;
- ◆ mvŷvrvKvi MŵYKvixi mnvqZvqj-K I MVbgj-K`wófwz ;
- ◆ wbgwZ mvŷvrvKvi Abŷv I Kivŵúv`b m⁹útkZ cŵZw mgm`vi c⁹úK c⁹úK
gj`vqb |
- ◆ mvŷvrvKvi MŵYKvix KZŷ mgm`v mgvavb c⁹úZ MŵtYi gvbwmKZv |

Gŵvov tggvi (Meyer, 1960) GKwŵ we`ŷ tKv⁹úvbxZ gj`vqb m⁹útkZ AvfÁZvi
Avtj vtK gj`vqb m⁹útk⁹KtqKwŵ, iazc⁹ŷw K Ztj atitQb hv wKŷtKi Kgŵúv`b
gj`vqb mvŷvrvKviti, i⁹z⁹ji mvt` weŷePbv Kiv P⁹tj | G⁹ tjv nj :

**Kgŵúv`b gj`vqtb
KtqKwŵ weŷeP`w K**

- mgvtj vPbv j ŷŷ ARŷb tbwZevPK cŷve tdtj ;
- cŷsmv tKvb bv tKvb fvte dj`vqK nq ;
- hLb D⁹t⁹k` mŷw ŷfvte wbiŷcZ nq ZLb Kgŵúv`tbi gvbI DbZ nq ;
- mgvtj vPbvqj-K gj`vqtb e⁹úzi AvZŷ ŷvi cŵPón Kgŵúv`tbi gvb⁹tK wbgwlyx
Kti ;
- mvŷvrvKvi wbgwZfvte nte, eQti GKevi gv⁹l bq ;
- mgvtj vPbv bq, cvi`úwi K j ŷŷ wbaŷ Y Kgŵúv`tbi gvb ewx Kti ;
- e⁹úzi Kgŵúv`tbi DbqbtK mvgtb ti tL mvŷvrvKvi cwíKíbv Kitz nte,
teZb ewx ev Pvkwi tŷt⁹ c⁹vbwzi Rb` bq ;
- D⁹t⁹k` wbaŷ Y cŵ⁹q mvŷvrvKvi MŵYKvixi AskMŵY BwZevPK dj etq Avtb |

3. Kgmáúv`b gj`vqb Abyvi K KivR

Kgmáúv`b gj`vqb cǫqvri mePvBtZ , iazcY[®]-li GilU| cKZctŋ GKUW gj`vqb cǫqvri meKymthvM`Zv (credibility) G ᚦii mdjZvi Dci wbfPkj| G chŋq j ŋŋvŋvi ev`evqb cwiexŋY (monitoring) Kiv nq| Kgmáúv`b gj`vqb dtjvAvc `ŋvte Kiv hvq| cǫgZ: gj`vqtb wbaŋi Z j ŋŋ` ARŋb mnvqZvi Rb` Ab`i i w`tq dtjvAvc Kiv Ges wZxqZ: gj`vqbKvix KZŋ dtjvAvc| GtZ Kti j ŋŋ` wbaŋiŋYi mvt_ gj`vqbKvixi `wqZi tkl nte bv, eis Zv ev`evqtb G Kiu avivemK `wqZi Zvi Dci eZŋe| dtjvAvtci Rb` GKUW wv`ŋ mgq cwiKíbv `vKte hvi wfvE`tZ dtjvAvc cwiPwj Z nte|

Kgmáúv`b gj`vqb cǫqvri cǫg `w ᚦi hZB AMŋwZ cwi j wŋZ tnvK bv tKb Zvi A`bKUvB nmi tq hvte hw` bv dtjvAvc chŋq h_vh_ hZæbv tbi qv nq| ZvB gj`vqb msuvsŋ wvfbæMtel Yvi mŋvvi tK G chŋqi Dci A`bK tewk , iazit`l qv ntqtQ| cǫZovtbi th tKvb Kgr[®]ev wKŋtKi gj`vqb Kitz ntj Aek`B Zvi dtjvAvc `vKtZ nte| wKs` ŋLRbK ntj l mZ` th, A`bKtŋŋŋ G wv qv Aetjv Kivi cŋYzv j ŋŋ Kiv hvq| Avevi tKvb tKvb tŋŋŋ GilU ntq `vtK KZŋgj-K ev wqšŋgj-K| dtj Kgmáúv`b gj`vqtb cKZ.Dtí k` ARŋ e`vZ nq|

Kgmáúv`b gj`vqb cǫqvri dtjvAvtci mvt_ mvt_ wKŋtKi mvt_ dtjvAvtci cǫB wv lq wbtq chŋj vPbv mfv AvtqvRb Kitz nte| GB chŋj vPbv mfv AvbŋmbK Ges gvtS gvtS (casual) -GB `yati tbi ntZ cvti | AvbŋmbK mfv wbaŋi Z mgtq wbaŋi Z `vtb AbŋZ nte, Avi casual mfv wvfbæmgatq cǫqvRb Abŋvqx AbŋZ nq|

dtjvAvc chŋj vPbv mfv LŋB , iazcY[®] GilU gj`vqbKvix Ges gj`vqtki gta` tckvMZ m`úK[®]ewtZ AvbŋmbK mŋhvM mwp Kti | Kgmáúv`tbi j ŋŋŋvŋv KZUv AvRŋ ntqtQ tm m`úK[®]thŋ_ Avjvc Avtj vPbv wfvE`tZ wv`vŋŋMŋŋY Ges ev`eagx[®] fvel`tZ Kgevi Kíbv wbaŋiŋY dtjvAvc chŋj vPbv mfv wvKí tB|

Dcwi D³ Avtj vPbvq j ŋŋYxq th, Kgmáúv`b gj`vqb cǫwZ, gj`vqb mnŋvrvKvi Ges dtjvAvc-G wZbvU ᚦii mgštq MvZ GKUW avivemK cǫqv| Zte G ᚦi , tjv cǫZovtbtŋ` wvfbæiKg ntZ cvti | tKD tKD Avevi Kgmáúv`b gj`vqb cǫqvri avc , tj vtK wvfbævte wv`lKti tQb| Zte th fvteB gj`vqb cǫqvU AbyvZ tnvK bv tKb, gj`vqb m`úK[®] Avtj vPbv t`tK Guv mýúó th, wKŋK l cǫZovb Dftqi Rb`B GilU AZ`šDcKvix|



ci#V#Ei gj`iqb 3.2

A) msi#B D#Ei c#k#e

1. nb#I #cqv#m# g#Z #k#I#Ki Kg#m#úv` b gj`iq#bi Dcv`vb_#tj v Kx?
2. Kg#m#úv` b gj`iqb c#m#qvi c#i#Zc#e#m#úv# Ze` Kg#R#v#Ú_#tj v Kx?
3. Kg#m#úv` b gj`iq#bi gvb`Ú #ba#I#Y #Kvb #Kvb # K we#e#P#v# Kiv D#P#Z?
4. Kg#m#úv` b gj`iq#bi c#i#tek m#i#i c#q#v#R#b#q#Z#v m#t#I#t#c e`v#L`v# K#i#b#|
5. Kg#m#úv` b gj`iqb m#v#I#v#Z#K#v#i#i g#t#v#%#Á#v#b#K m#g#m#v`_#tj v Kx?
6. Kg#m#úv` b gj`iqb m#v#I#v#Z#K#v#i#i m#v#d#t#j`i k#Z#e#i#j D#t#j Ú#L# K#i#b#|
7. Kg#m#úv` b gj`iqb c#m#qvi d#t#j#v#A#v#c`#i#v#U#h#_#v#h#_#f#v#e# A#b#v#Z#b#v#n#t#j# K#x#m#g#m#v`#n#t#Z#c#v#i# ?
8. d#t#j#v#A#v#c#h#e#j#v#P#v#v#m#f#v#K#q#a#i#t#b#i#n#t#Z#c#v#i#I#K#x#K#x#?

A#v) i#P#v#q#j#-K# c#k#e

1. #k#I#t#Ki Kg#m#úv` b gj`iqb c#m#qvi a#v#c_#tj v m#t#I#t#c e#Y#v#v# K#i#b#|
2. Kg#m#úv` b gj`iqb c#m#qvi c#ú#v#g#K`#i#m#úv# Ze` Kg#R#v#Ú_#tj v e`v#L`v# K#i#b#|
3. Kg#m#úv` b gj`iqb m#v#I#v#Z#K#v#i#i m#úv# Ze` Kg#R#v#Ú, B#m#y#G#e#s#m#d#j#Z#v#i# k#Z#e#i#j#D#t#j#L# K#i#b#|
4. A#g#v#i#i#t#t#k#i# #k#I#v#c#ú#Z#v#b#m#g#f#n# #k#I#t#Ki Kg#m#úv` b gj`iqb c#m#qvi`#t#f#c#D#t#j#L#K#i#G#i#g#v#t#v#b#q#t#b#K#t#q#K#v#U#m#g#v#i#k#D#t#j#L#K#i#b#|

ibafiy Ges Avil Z` msMni cwi Kib hv GKBFvte msMpxZ nq| G cxwzi`
`enkó` nj GtZ Duj m LZ wZbuU `li avivvwnKfvte Abyiy Kitz nq|

Clinical supervision **ch`uqv**

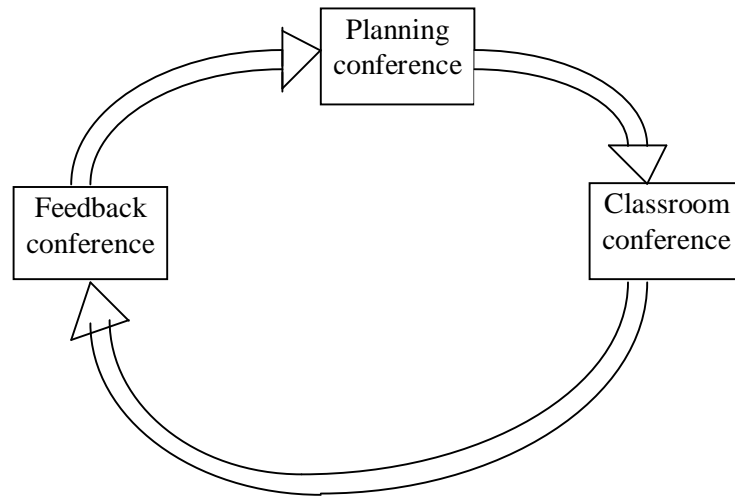

uPÍ 3.3-1 : Clinical supervision **ch`uqv**

Semi-structured observation : G cxwziz` wk`K tKvb we`kl cwiw`wzi Dc`hvMx Kti` w`b`RB GKwU ch`e`Y Kvh`eg `Zwi Ktib| GtZ wk`Ke,` GtK Actii` wk`v`vb Kvh`eg ch`e`Y Ktib Ges wk`v`vtbi tg`uj K w`lq, thgb- c`kæ Kivi tKSkj, tkYxK` e`e`vcbv, wk`Kti AvPiY BZ`w` w`lq Z` msMh Ktib| GtZ wk`Ke,` w`b`Riv ch`e`Y Kvh`eg `Zwi Ktib etj Zviv Gi mvt_ GKvZ`eva Ktib| dtj ch`e`Yi D`ik` Ges Z` msMh cxwzi gta` fij Lvc Lvq| ch`e`Y Kvh`eg `Zwi mgq w`tgw` c`k`jvi D`vcb ch`e`Yi D`ik` AR`K MwZkxj Kitz cvti |

ch`e`Y Kvh`eg `ZwiZ w`teP` w`lq

- ch`e`Yi D`ik` Kx?
- wk`Kti wk`v`vb ch`uqv tKvb w`K,`tjv ch`e`Y Kiv nte?
- ch`e`Yi gj-j` w`y`Kx nte?
- DcvE` msMni tKvb cxwziU D`ik` AR`bi Rb` mte`eg nte?
- msMpxZ DcvE` wk`fvte e`e`uZ nte?

Coding Scale: wk`Kti Kg`u`b gj`vq`bi t`t` h`w`l wk`Kti `c`v`Z ch`e`Y t`j Awakzi Mh`Y`th`M, Z`mc A`bK mgq ms`w`BZvi Kvi`Y tmUv nq bv| GQ`ov c`e`D`w`eZ wk`QyAv`k`qZ ti`Us A`ev tKw`W t`j `vKtZ cvti hv ch`e`Yi D`ik`i mvt_ Lvc tLiz cvti | Gme ti`Us A`ev tKw`W t`j i gva`tg| wk`Kti Kg`u`b gj`vqb Kiv thtZ cvti |

ukʻɥv_xʻKZʻ gj`iqb

ukʻɥtKi Kgmʻuv`b gj`iqtb ukʻɥv_xʻ i gZvgZtK Z` mḶ wntmte e`enviti i wel qul
weZiKZ| wekI Kti cāv ukʻɥK I ukʻɥKeḶ`i G welḶ Avciē`vKtZ cvti| Zte
KgḶmʻuv`b gj`iqb mspuʻsḶ newfbæMtēl Yvq Gi DcḶhVḶvZv cŷmYZ nḶqḶQ| ukʻɥv_xʻ
KZʻ ukʻɥtKi KḶRi gj`iqb Avmtj GK aiḶbi chḶeŶY Ges Zv nḶq`vḶK
ukʻɥv_xʻ i`wḶfWḶZ| mḶaviYZ KḶj R I wekɬe`ij Ḷq G c×uZi cḶj b Ḷ`Lv hvq|
Zte AtḶḶK gḶb KḶib cḶ`igK I gḶa`igK ukʻɥv `Ḷi I ukʻɥtKi KḶRi gj`iqtb G
c×uZi cḶZḶ mḶj eḶq AvḶte|

ukʻɥv_xʻ KḶZZj

ukʻɥv_xʻ KḶZZj gj`iqb ukʻɥtKi Kgmʻuv`Ḷbi KḶhḶvixZvi Avi GKḶ Ab`Zg Z`
Drm| Zte GiUl GKḶ weZiKZ Z` Drm| KḶiY AtḶK ukʻɥK Ges cḶvmK gḶb
KḶib th, gj`iqḶbi DḶi`K`B nḶ`Q ukʻɥv_xʻ ukLb I ukʻɥvi DbḶb| Avi GB DḶi`k`
ARḶbi mḶj Zv cḶkḶkZ nḶ ukʻɥv_xʻ KḶZḶZj| ukʻɥv_xʻ KḶZZj newfbæcvi w`WZḶZ
newfbæKg nḶZ cvḶi Ges Gi newfbæwbqšYKḶix Dcv`vb iḶḶqḶQ| AZGe, GiUl
ukʻɥtKi Kgmʻuv`b gj`iqḶbi wḶfḶḶM` cḶḶqv bḶl nḶZ cvḶi | G mḶḶtj vḶbv mḶEḶl
GiUl Kgmʻuv`b gj`iqḶbi GKḶ `i aZc`Z` Drm|

Dcvi wj mLZ newfbæDrm Ḷ`ḶK Z` msMḶKiY Ges gj`iqḶbi h_vh_ cwiḶek mḶḶ I
gḶv`Ū cḶḶqḶbi gḶa`Ḷg ukʻɥtKi Kgmʻuv`b gj`iqḶbi DchḶḶ tcŶcU `Zwi Kiv
mḶe|



cvḶVḶEi gj`iqb 3.3

A) msḶḶB DḶEi cḶkæ

1. ukʻɥtKi Kgmʻuv`b gj`iqḶbi Z` Drm Kx Kx nḶZ cvḶi?
2. ukʻɥK Kgmʻuv`b gj`iqḶbi tkYxKŶ chḶeŶY tKšKj Kqul I Kx Kx?
3. tkYxKŶ chḶeŶYi Clinical supervision cḶḶqv eYḶv Ki ab|
4. Semi-structured observation schedule cḶḶqḶbi weḶeP` wel q_ Ḷj v Kx?
5. ukʻɥtKi Kgmʻuv`b gj`iqḶbi Ḷgj`iqb cḶḶqv eYḶv Ki ab|
6. ukʻɥv_xʻKZʻ ukʻɥtKi Kgmʻuv`b gj`iqb cḶḶqv mḶḶtK`Avcbri `wḶfWḶ ukIjc?
msḶḶc hḶḶmnKḶḶi DḶj L Ki ab|

Av) iḶbḶqj-K cḶkæ

1. ukʻɥtKi Kgmʻuv`b gj`iqḶb tkYxKŶ chḶeŶY cḶḶqv Ges Gi `i aZj eYḶv
Ki ab|
2. ukʻɥtKi Kgmʻuv`b gj`iqḶbi newfbæZ` Drm_ Ḷj vi eYḶv w` b|

cW 3.4

Kgᄁúv` b gj`vqᄁbi mgm`v I gvᄁbvbqᄁ

[Problems of Performance Appraisal and its Development]

Dᄁik`

GB cW ᄁkᄁI Avrcwb-

- Kgᄁúv` b gj`vqᄁ c×vZi mᄁgve×Zv Dᄁj ᄁ KiᄁZ cviᄁeb;
- Kgᄁúv` b gj`vqᄁbi vevfbvqᄁᄁbi%ÁvnbK mgm`v I ávᄁšeYᄁv KiᄁZ cviᄁeb;
- Avgvᄁ`i ᄁᄁki vKᄁᄁK Kgᄁúv` b gj`vqᄁ cᄁᄁqvᄁ mᄁgve×Zv vPvᄁZ KiᄁZ cviᄁeb Ges
- Kgᄁúv` b gj`vqᄁbi gvᄁbvbqᄁbi Dcvq vbᄁ`R KiᄁZ cviᄁeb|

eZᄁvb BDvbᄁUi ceᄁZv`civ, ᄁjvᄁZ Avgiv Kgᄁúv` b gj`vqᄁbi vevfbvqᄁZvEᄁK I e`envvi K v`K mᄁúᄁKᄁᄁRᄁᄁQ| ᄁmB mᄁᄁ_ Avgiv Avil ᄁRᄁᄁQ vKᄁᄁKᄁ`i ᄁckvMZ gvᄁbvbqᄁbi gvᄁᄁᄁ vKᄁᄁv cᄁZᄁᄁᄁbi ,YMZ gvᄁbvbqᄁ Ges vKᄁᄁv Kvhᄁᄁᄁᄁi mdj I Kvhᄁᄁᄁ ev`bvqᄁᄁbi GKvᄁ Ab`Zg Dcvq nj vKᄁᄁᄁKi Kgᄁúv` b gj`vqᄁ Ges ᄁm Abᄁvᄁq e`e`v MᄁY| vKᄁᄁ` Kgᄁúv` b gj`vqᄁ mnR bq eis GKvᄁ RvᄁJ KvR| Gvᄁ hZ cvi Kvᄁ Z Dcvᄁq Ges vbᄁᄁi Z avc I gvᄁ`Ú AbᄁvᄁY KᄁiB cvi Pvj Z ᄁnvK bv ᄁKb, AᄁbKᄁᄁᄁᄁᄁB Gi tek vKᄁᄁmᄁgve×Zv cvi j vᄁᄁZ nq| ᄁᄁj Kgᄁúv` b gj`vqᄁbi h_vh_ gvᄁ ARᄁ mᄁe nq bv| Kgᄁúv` b gj`vqᄁbi G mᄁgve×Zv, ᄁjv mᄁᄁᄁᄁc vbᄁP Dᄁj ᄁ Kiv nj |

Kgᄁúv` b gj`vqᄁ c×vZi mᄁgve×Zv

1. gj`vqᄁ bmvZgvj v mᄁúú bq, RvᄁJ ZvcYᄁ;
2. gj`vqᄁKvix KgᄁZᄁ`i gj`vqᄁRvbZ `ᄁᄁZvi Afve ;
3. gj`vqᄁ vbᄁvi Afve I Abvrv ;
4. cᄁᄁcvᄁZ;I `beᄁᄁKvxbZv ;
5. avivvvnKZvi Afve ;
6. gj`vqᄁ cᄁqvRbxq kᄁᄁ I gbbkxj Zv cᄁqvᄁMi Afve ;
7. ᄁhvMᄁᄁᄁM I vᄁWv`vK cᄁᄁᄁ `ᄁᄁZv Ges hvᄁK gj`vqᄁ Kiv nᄁ`Q G e`vcᄁᄁi ZvᄁK vKᄁᄁv Rvbᄁᄁv ;
8. gj`vqᄁ cᄁᄁqvᄁ hvᄁK gj`vqᄁ Kiv nᄁ`Q Zvi AskMᄁY bv`vKv Ges
9. Ah_v n`ᄁᄁᄁc ev Pvc mᄁᄁ|

KgᄁᄁᄁZvi gj`vqᄁbi ᄁᄁᄁᄁ mᄁW gvᄁ vbYᄁᄁ Dcᄁiv³ mgm`v, ᄁjv evav vᄁᄁᄁᄁ Kiv Kᄁi |

mᄁgve×Zv

Kgŕuv`b gj`vqtb i veifboqtb i %ÁvbK mgm`v ev ávš

AþK mgq Kgŕuv`b gj`vqtb i Kvrw veifboqtb i ceŕs`vi ev ávš ðv iv cŕveZ nq| dtj AþK tŕt` gj`vqbKvixi KvŦ cŕcvZnxb l e`vbo Kgŕuv`b gj`vqtb `jŕn nŕq cto| vþP G aiþbi KtqKw gtb %ÁvbK mgm`v vþq Avtj vPbv Kiv nj | vKŕK Kgŕuv`b gj`vqtb G mKj ávš m`úK`gj`vqbKvixi mþPZb `vKv cŕqvRb|

áek ávš

áek ávš (Constant Error): cŕZ`K gj`vqbKvixi KZ, t jv vR`^a`v aviv, `vŕfiv l gj`vera `vK, th, t jv Kgŕuv`b gj`vqtb i tŕt` Zvi vePvitevtai KvVtgv vntmte KvR Kti | dtj veifboqtb i Kti gj`vqtb i gvb Zvi Zg` cwi j vŕZ nq| G aiþbi ávš nj áek ávš | thgb- tKvb tKvb gj`vqbKvixi gta` D`vi Zvi KvŕtY cŕZvqZ D`P gj`vqtb i cŕYZv t`Lv hvq| GtK ejv nq D`vi Zvgj-K ávš (Leniency error) | tKvb tKvb gj`vqbKvixi Lg KovKvofite gj`vqb Ktib| dtj gj`vqtb i gvb vbgvþbi nŕq `vK| G aiþbi ávš K etj KvVtgvRvbZ ávš (severity error) | Avevi AþtK cŕšK ev Povš gZvgZ cwi nvi Kti gvSvms aiþbi gZvgZ t`b hv tK`gŕ ávš (central tendency error) vþq cwi vPZ|

ce`gj`vqtb i cŕve

ce`gj`vqtb i cŕve (Halo Effect) : ce`aviYv ev AvfÁZvi dtj gj`vqtb cŕcwiZZ; ev ÁvUB nŕ`Q ce`gj`vqtb i cŕve| A`ŕ hLb tKvb e`v`i GKw mekl `enkó` m`úK`gj`vqbKvixi ce`t`KB AbKj ev cŕZKj aviv `vK Ges H e`v`i Ab` tKvb `enkó` gj`vqtb i tŕt` hŕ` gj`vqbKvixi tmB aviv ðv iv cŕveZ nŕq AvZ D`P ev vbgvþbi gj`vqb Ktib, ZLb GtK ce`gj`vqtb i cŕve ejv hvq|

thš`K gj`vqb ávš

thš`K gj`vqb ávš (Logical Rating Error): G aiþbi ávš ce`gj`vqtb i cŕveRvbZ ávš i Abj/c| hLb tKvb gj`vqbKvixi tKvb e`v`i `v` `enkó` tK hŕ`m`Zvŕte m`v`KZ gtb Ktib, ZLb GKw D`Pgþbi Rb` Ab`v`Kl D`P gj`vqb Ktib, dtj G aiþbi ávš NtU|

`ecix` l m`k ávš

`ecix` l m`k ávš (Contrast and Similarity Error): G aiþbi ávš gj`vqbKvixi AvZ`cŕ`ŕt`Yi Dci vbfPkj | thgb- tKvb gj`vqbKvixi Ab` tKvb e`v`i , Yvej hŕ` vþRi , Yvej i m`_ mvgÁm`cY`gþb Ktib Zvntj vZv ZvK Lg fij l `ŕ vntmte gj`vqb KtZ cvþb| Avevi e`v`i , Yvej hŕ` vevixZag`nq Zvntj ZvK mr gj`vqb Kiteb v| G aiþbi ávš Kgŕuv`b gj`vqtb i `be`KZvK bó Kti |

eisj v`tki vKŕK Kgŕuv`b gj`vqb cŕqv l Gi mvgv`Zv

Kgŕuv`b gj`vqb cŕqv i D`e

Gt`k Kg`ŕZv gj`vqb c`v`Zi cŕg D`e NtU veUk Avgtj miKwi Avdm Av`v Z, t j vZ| tm mgq miKwi cŕZv`v, t j vZ eml R tMvbxq cŕZte`b e`vi gva`g KgPvix`i thv`Zv, e`v`Z; Pwi vK `enkó`vej BZ`w hŕvB Kiv nŕZv c`v`Z cŕ`v`Z, e`v` l teZb ev`i tŕt` | 1947 mŕtj t`k fivMi cil G e`v` cŕv`Z vQj Ges tm mgq tek KtqKevi Zv cwi gvR`bi gva`g gvþvqþbi cŕv`v tbi qv nq| Bst`Rt` i cŕv`Z c`v`Zi tPq D`v mgq Mv`Z c`v`Z Z`v`v`Kvŕte

თუკ Z_ mgx Ges bgbxq ntj I Zv cqvcwZZ; t`v l `y, tMvcbxq Ges `be`KZvnx b wQj | ersjv`k `vaxb n l qvi cti Kg`qZvi gj`vqb e`e`v Dbz Kivi cqm tbl qv nq| G cP`ovi Aaxb 1982 mtj dg`Averi l cwi gvR` l ms`vi Kiv nq| G gj`vqb e`e`vaxb uk`qv ckvmtbi mt` RwoZ cl`g tkYxi KgRZP`t`K iia Kti cl`igK, gva`igK Ges Ktj R ch`qi uk`qKt` i Kg`qZvi gvb hvPvBtqi e`e`v itqtQ| GtZ wefbaetbi tMvcbxq cl`Zte`b dig -Gi gva`tg wefbaech`qi uk`qKt` i Kg`muv`b gj`vqb Kiv ntq `vtK|

**უკუკ Kg`muv`b
gj`vqtb i wefbaet K**

მრავი Yvte KgRZP`ev uk`qKt` i wKUZg EaYzb e`i` ewl R tMvcbxq cl`Zte`b wj tL `vtKb Ges cieZ`ch`q D³ w`tcwU` Awdmv`i EaYzb KgRZP`cl`Z`q`i Kti `vtKb| G e`vcti miKv`i ms`vcb wefv`mi b`wZg`v AbyZ ntq `vtK| miKvi cl`igK I gva`igK we`vj`qi c`vb uk`qKt` i ewl R tMvcbxq cl`Zte`b ckvmtbK, Z`E`vav`bK I uk`qvMZ w`K gj`vqZ nq Ges mnKvix uk`qKt` i ewl R tMvcbxq cl`Zte`b uk`qv Ae`vb, uk`qv vb Kvth` mdj Zv, mncv Kvh`w, mvgnRK I MYmsth`M Kvh`w` BZ`w` gj`vqtb i e`e`v itqtQ| cl`g tkYxi KgRZP` ch`qi uk`qKt` i ewl R tMvcbxq cl`Zte`b R`eb e`v`S, `r` cix`vi cl`Zte`b, e`i`MZ `ek`o, uk`qvMZ Kv`muv`b, tckvMZ Avb BZ`w` wefbaet K gj`vqZ ntq `vtK| GtZ t`Lv hvq wefbaetbi cwi gvR`bi gva`tg eZ`vb Kg`muv`b gj`vqtb i cwi wa A`bK we`Z.I `YMZgvb m`ub`eKivi cqm MpxZ ntqtQ| Zv mt`E`l eZ`vb gj`vqb c`wZi cl`Z` m`gve`Zv itqtQ hv wbg`f`c:

**Kg`muv`b gj`vqb
cl`qv i m`gve`Zv**

- gj`vqb ariv`w`Kfvte nq bv| eQt i gv`l GKevi Avb`w`bKfvte Kiv ntq `vtK|
- gj`vqbKvixi cl`qvRbxq Avb I cl`q`Yi Afvte gj`vqtb i D`l`k` e`vnZ nq|
- w`tcwU` Awdmv`i Kv`Q gj`vqtb i Rb` tKv wj wLZ Z_ `vtK bv| dtj tM`w` A`bKv` `yZ w`f`p` nq Ges GtZ Z`_i w`f`p`xj Zv I w`i`c`qZv e`vnZ nq|
- gj`vqb cl`Zte`b `Zwi t`q`T `x`w`Zv GKw` weivU mgm`v w`nt`te KvR Kti |
- gj`vqb cl`qv m`u`Y`Mvcbxq n l qvq A`bK mgq hv`K gj`vqb Kiv nq tm Zvi Kv`Ri gvb m`ut`K`A`w`Z nq bv| dtj w`t`Ri Kvh`muv`b`i gvb m`ut`K` cwi`vi avi Yv Rb`q bv Ges AvZ`w`q`S`Yi cP`ov Kg `vtK|
- G c`wZtZ gj`vqb `be`K n l qvi c`YZv Kg| Kvi Y gj`vqbKvix Ges hv`K gj`vqb Kiv nq Zvi e`i`MZ m`u`K`I m`u`ZK NUb`v`j A`bKt`q`T gj`vqtb K c`w`Z Kti |
- A`bKt`q`T gj`vqb Mvbgj-K I Db`qbgj-K bv ntq t`Kej t`vl w`p`y`ZKi`Y m`gve` `vtK hv gj`vqtb i D`l`k`t`K cl`Z`d`w` Z Kti bv|
- cl`Zte`b KgRZP`K A`bK mgq cl`Zte`b m`u`K`w`efb`Pv`t`ci m`y`x`b ntZ nq|

- eZŷvb wKŷK Kgŷúv`b gj`vqb cŷuqv GKKfite cwi Pwŷ Z nq etj GtZ wKŷtKi AskMŷtYi mŷhvm tbB| thS_ cŷuqv cwi Pwŷ Z bn l qvq GtZ AvZŷ gj`vqb l AvZŷDbqŷbi mŷhvm tbB| hv bvmK mŷz Kvhŷi gj`vqŷbi ceRZŷ
- KgŷŷZvi gj`vqŷb follow-up -Gi mŷhvm tbB ej t j B Ptj |
- DcwD³ mxgve×Zvi KviŷY Kgŷúv`b gj`vqŷbi gva`tg tckvMZ Dbqŷbi mŷhvm LŷB mxwZ|

wKŷK Kgŷúv`b gj`vqb cŷuqv gŷbvqŷbi Dciq

wKŷtKi KgŷŷZvi gj`vqb GKŷWwŷK e`e`vcbvi GKŷW_ iaZcŷw`K| gj`vqŷtK wKŷv cŷvmb l e`e`vcbvi GKŷW avivevwnK cŷuqv wntmte Mto ZŷtZ cvi t j wKŷv e`e`v nte `ŷ, MwZkxj Ges Dbqbgŷx| ZvB th tKvb wKŷv cŷZŷvŷb KgŷZ wKŷtKi KgŷŷZvi gj`vqŷbi GKŷW DbzZi e`e`v Mto tZvjv DŷPZ| GKŷW Dbz KgŷŷZvi gj`vqb c×wZi wbgŷ wLZ `eikó`vej_ vKv cŷqvRb|

Dbz KgŷŷZvi gj`vqb c×wZi `eikó`

- mŷwi Kŷr Z l mŷsMwZ;
- avivevwnK, eQti tKej gvŷ GKevi ev `ŷvi bq;
- mnR l tevaMg`;
- Abrek`K RŷwJ ZvevRŷ;
- ev`é l cŷqvMgŷx;
- Abŷvb wbfŷ bq, eis Z_` wbfŷ;
- h_v_ŷ wbfŷŷhvm`;
- c×wZi gvB Dbqŷbi Rb` gj`vqŷbi mŷhvmMŷwŷ Z;
- gj`vqbKvixi `ŷZvi ewx i mŷhvm l cŷKŷtYi e`e`v;
- tckvMZ weKv`k mnvqK Ges
- AvZŷgj`vqŷbi Dci_ iaZŷtvc|

Dctiv³ `eikó`_ t j v Kgŷúv`b gj`vqŷbi gŷbvqŷb mnvqK| weŷki weŷfbet`tk weŷkl Kti Dbz t`k_ t j vtZ wKŷtKi Kgŷúv`b gj`vqŷbi Dci Awei Zfite MtelYv Pŷj vtbn nq| Gi dtj cŷZŷvŷbi `ŷZvi evto, wKŷvi Kvhŷwŷi Zv ewx cvq Ges j ŷŷvRŷ mŷe nq| Avgt` i t`tk wKŷvi_ YMZgvb wbtq AvR mskq t`Lv w`tqtQ Ges_ YMZgvb wŷwZKiŷY MpxZe` weŷfbec`ŷŷtci gta` wKŷtKi Kgŷúv`b gj`vqb Ab`Zg_ iaZcŷŷ MtelKt`i gŷZ Kgŷúv`b gj`vqŷbi gvB Dbqŷb KitZ ntj wbgŷ wLZ c`ŷŷc_ t j v MŷY Kiv DŷPZ|

gj`vqŷbi bŷZgvjv wbaŷY

1. gj`vqŷbi bŷZgvjv wbaŷY Kti tm mŷútk`msŷkŷ e`w³eMŷK AeinZ KitZ nte| thgb- tK gj`vqb Kiteb, KvŷK gj`vqb Kiv nte, Kx gj`vqb Kiteb Ges wKŷfite l KZevi gj`vqb Kiteb BZ`w` wela_ t j v mŷútk`cŷeB bŷZgvjv wbaŷY l AeinZKiY KitZ nte|



cvŷVĚi gj`vqb 3.4

A) msuŋB DĚi cĕæ

1. Kgŋiúv`b gj`vqb c×uZi mxgve×Zv, tj v Kx ?
2. aæK áwšl Kx ? GuU Kgŋiúv`b gj`vqbtK űKfŷte cŷmeZ Kŷi ?
3. Kgŋiúv`b gj`vqbtbi gŷbr%ÁvbK mgm`v, tj v Dŷj L Ki ab |
4. evsj v`tk Kgŋiúv`b gj`vqb cĕuqvi DrcuĚ eYŋv Ki ab |
5. evsj v`tki Kgŋiúv`b gj`vqb cĕuqvi cĕuU cĕvb mgm`v Avŷj vPbv Ki ab |
6. Dbæ Kgŋiúv`b gj`vqb c×uZi `ewkó, tj v Kx ?

Av) iPbvj-K cĕæ

1. Kgŋiúv`b gj`vqb c×uZi mxgve×Zv l gŷbr%ÁvbK mgm`v, tj v eYŋv Ki ab |
2. evsj v`tki űKŋK Kgŋiúv`b cĕuqvi l Gi mxgve×Zv Dŷj L Ki ab |
3. Kgŋiúv`b cĕuqvi gŷbrvqŷb MpxZe` c`ŷŋc, tj v eYŋv Ki ab |



Povšġ gj`vqb -3

A) msuŋB DĚi cĕæ

1. Kgŋiúv`b gj`vqb ej ŷZ Kx eŷvq ?
2. űKŋŷKi Kgŋiúv`b gj`vqbtbi Zirch`e`vL`v Ki ab |
3. Kgŋiúv`b gj`vqb cĕuqvi avc, tj v Dŷj L Ki ab |
4. Kgŋiúv`b gj`vqbtbi cwi tek mŷi cĕqvRbxqZv Kx ?
5. Kgŋiúv`b gj`vqb cĕuqvi dtj vAvc `liuU h_vh_fvte AbyzZ bv ntj Kx mgm`v ntZ cvŷi ?
6. Kx Kx Dm ŷŷK Kgŋiúv`b gj`vqbtbi cĕqvRbxq Z` cvl qv hvq ?
7. űKŋŷKi Kgŋiúv`b gj`vqbtbi `gj`vqb cĕuqviU eYŋv Ki ab |
8. Kgŋiúv`b gj`vqb GKU Rŷj cĕuqv tKb ?
9. Kgŋiúv`b gj`vqb c×uZi cĕuU mxgve×Zv Dŷj L Ki ab |
10. űKfŷte Kgŋiúv`b gj`vqb c×uZi mxgve×Zv, tj v `ŷfZ Kiv hvq ?
11. `eci xZ` l mŷk áwšl űKfŷte Kgŋiúv`b gj`vqb cĕuqvtK cŷmeZ Kŷi ?
12. evsj v`tk űKŋK Kgŋiúv`b gj`vqb c×uZi PriuU mxgve×Zv weeZ Ki ab |

Av) iPbvj-K cĕæ

1. űKŋK Kgŋiúv`b gj`vqbtbi Dŷl`k, tj v weeZ Ki ab |
2. űKŋK Kgŋiúv`b gj`vqb cĕuqvi avc, tj v mŷŷŷc eYŋv Ki ab |
3. Avqv`i ŷŷki űKŋv cĕZóvbmgŷ űKŋŷKi Kgŋiúv`b gj`vqb cĕuqvi `ŷc Dŷj - LceR Gi gŷbrvqŷb KŷqKŷU mŷwi k Dŷj L Ki ab |
4. űKŋŷKi Kgŋiúv`b gj`vqbtbi tkYxKŋ chŷŷŷY cĕuqv Ges Gi, iaZj eYŋv Ki ab |
5. Kgŋiúv`b gj`vqb c×uZi gŷbr%ÁvbK mgm`v, tj v Kx? űKfŷte G, tj v Kgŋiúv`b cĕuqvtK cŷmeZ Kŷi Avŷj vPbv Ki ab |
6. Kgŋiúv`b gj`vqbtbi mŷj Kx? GuU cwi Pj bvq űK bŷZgvj v AbyzZ n l qv cĕqvRb - Dŷj L Ki ab |

cW 4.1

KgxDbq̄b : avi Yv, Dt̄ik̄, cwimi, welq Ges , iaZj

[Staff Development : Concept, Objectives, Scope, Subjects and Importance]

Dt̄ik̄

GB cW tk̄tI Avcib –

- KgxDbq̄tbi avi Yv e³ Ki tZ cvi tēb ;
- KgxDbq̄tbi Dt̄ik̄ weZ Ki tZ cvi tēb;
- KgxDbq̄b c̄uqvi cwimi eȲv Ki tZ cvi tēb ;
- wk̄ŷt̄ŷt̄ KgxDbq̄tbi t̄ŷt̄ PwŷZ Ki tZ cvi tēb ;
- KgxDbq̄tbi , iaZje`vL`v Ki tZ cvi tēb Ges
- c̄Pwŷ Z KgxDbq̄b c̄uqvi mŷve×Zv Dt̄j - L Ki tZ cvi tēb|

KgxDbq̄b Ges Kgm̄úv`b gj`vqb Nwbôfite msuk̄w| Kḡm̄úv`b gj`vq̄tbi Ab`Zg Dt̄ik̄`B nj Gi gva`tg c̄ŷ dj vdt̄j i w̄f̄E tZ c̄ŷq̄Rbxq t̄ŷt̄ KgxDbq̄tbi c`t̄ŷc M̄hY| ZZxq BDib̄tU wk̄ŷt̄Ki Kgm̄úv`b gj`vq̄tbi wef̄bae , iaZcȲw̄ K m̄útk̄ Avgiv tR̄t̄b̄Q| eZ̄ŷvb BDib̄tUi c̄ŷg cv̄tV Kgm̄úv`b gj`vq̄tbi avivew̄nKZvq KgxDbq̄tbi Kt̄qK̄w̄ avi YvMZ w̄ K w̄b̄tq Avt̄j vP̄bv Kiv nj |

KgxDbq̄b Kx?

KgxDbq̄tbi avi Yv

KgxDbq̄b m̄útk̄wef̄baemsAv c̄Pwŷ Z it̄q̄t̄Q, Zte m̄aviY A t̄`KgxDbq̄b ej tZ tKvb c̄Z̄ŷvb KZŷ M̄pxZ b̄wZgijv, Kgm̄P Ges c̄uq̄t̄K eS̄vq hv H c̄Z̄ŷvb Kgp̄Z e^{w̄3}e t̄M̄P w̄bR`^Dbq̄tbi gva`tg c̄Z̄ŷvb̄tbi Pw̄n`v cwic̄t̄Yi j t̄ŷt̄ M̄hY Kiv n̄tq `v̄t̄K (It includes institutional policies, programmes and procedures which facilitate and support staff so that they may fully serve their own and their institutional needs - Graham Webb, 1996)|

KgxDbq̄b Ges c̄ŷt̄ŷt̄Yi avi Yv

Kgx̄c̄ŷt̄ŷt̄Yi w̄KQywb̄w̄ ō welq Kgx̄K `f̄ cwim̄t̄i Rv̄v̄t̄bv nq| w̄KŠ Kgx̄Dbq̄tbi c̄w̄vb weteP` welq nj Kgx̄P i e^{w̄3}MZ c̄ŷw̄× ev Dbq̄b| Gt̄Z Kgx̄K wef̄baew̄l̄t̄q wk̄ŷv jv̄t̄fi m̄th̄vM c̄ŷv̄t̄bi gva`tg tKvb welq eS̄v̄t̄bvi, e`vL`v Kivi Ges ev`ev̄qb m̄s̄m̄v̄šl` ŷZv AR̄t̄bi Dci , iaZj t̄`l̄qv nq hv c̄K̄v̄v̄št̄i c̄Z̄ŷvb̄t̄bi Dbq̄t̄b m̄v̄v̄qK nq|

KgxDbq̄b Kgx̄c̄ŷt̄ŷt̄Yi t̄P̄t̄q w̄f̄b̄z̄i Ges A t̄bK t̄w̄k̄ f̄w̄el`Zḡŷx|

KგრDbაბი ცუმი

**KგრDbაბი Kუბრტი
ციმი**

KგრDbაბი th tKub cღZობი Rb AZ`vek`K| GKuU cღZობი mგZl KvbRix
cui Pvj bvi Rb`B KგრDbაბი cღqRb| Zte GKmgq tKej cღZობი cღvb ev
e`e`vcKt`i Rb` KგრDbაბი KგრM P MpxZ nZ| Avi ukv`v cღZობი tq`t`
ukv`KZvi mvt_ m`u`3t`i tckvMZ DbაბtK , iazj t` lqv nZ| eZგv`b KგრDbაბი
ციმი e`v` tctqQ| tKej gv` e`e`vcK ev ukv`KB bb, cღZობი KგPZ Ab`vb`
÷vd t` i l eZგv`b KგრDbაბი KგRv`Ui Avl Zvq ubtq Avmvi cღqRbrqZv`K , iazj
t` lqv n t`Q|

KგრDbაბი ბუZი Dტიk`

KგრDbაბი Dტიk`

ubDub l gv`K (Newton and Mack) -Gi g`Z KგრDbაბი ბუZგij v Mბt`Yi uZbuU g`y`
Dტიk` i tqtQ|

- cღZობი KგPZ e`w`3e`M`P (ukv`K Ges ukv`K bb Ggb e`w`3, `vqx Ges A`vqx, mnvqK ÷vd) Rb` arivem`K fite tckvMZ Dbაბი e`e`v Kiv|
- cღZობი KგPZ e`w`3e`M`K ubtRt`i tckvMZ cwi Kíbv MბY Ges tckvMZ m`h`vM-m`e`ari mბe`envti Drm`v`Z Kiv Ges
- KგPZ e`w`3e`M`P g`a` cღZობი `kბ, e`e`vcbv, cwi Kíbv, j`q` l Dტიk` BZ`w` m`u`t`K`m`PZbZv m`p Ges G, t`j vi cღq`b l ev`évtb Zvt`i mg`_q `q` Kti tZvj v|

KგრDbაბი uelq

mivavi Yfite uerfb`e`cღZობი th uelq, t`j vtZ KგრDbაბი KvbRig AvtqRb Kiv nq Zv
nj – ckvmb, e`e`vcbv, Drcv`b, Mtel Yv, KugDubU m`v`f`m, ბუZ uba`f`Y BZ`w` |
Zte cღZობი c`K`u`Z`M`Z cv_`K`i u`f`w`É`Z KგრDbაბი t`q`T`l uerfb`e`iKg nq|
thgb- ukv`v`g`-K cღZობი cღvb cღZcv` uelq ukv`v`g`-K Dbაბ Z_v ukv`v`vb l
ukLb-tkLv`bv c`x`u`Zi Dbაბ| Avi ZvB G aitbi cღZობი KგრDbაბი KvbRig
ukv`v`g`-K Dbაბ Ges ukv`v`i , YMZგvb ubu`ð`Z`K`i`Y msuk- ó uerfb`e`w` Kt`K uNti
Avew`Z` n`q`_v`K| ukv`v`t`q`T`l KგრDbაბი uelqt`K ubt`w`3 fite tkY`e`x Kiv hvq:

**ukv`v`t`q`T`l Kგრ
Dbაბი uelq**

1. ukLb-tkLv`bvi Dbაბ (Instructional development): ukLb-tkLv`bv `q`Zv l
c`h`y`3, ukv`v`m`g cღq`b l Dbაბ, c`y`K ev uelq`e` cღq`b, g`j`v`q`b c`x`u`Z,
AY`k`q`Y, ukv`v`g`-K u`g`v`v`q` BZ`w` |
2. tckvMZ Dbაბ (Professional development): tckvMZ `v`q`Z`j` cvj`t`bi Rb` ukv`v`K
l msuk- ót`i e`w`3`M`Z `q`Zvi Dbაბ|
3. m`v`M`v`b`K Dbაბ(Organizational development): ukv`v`v` cღZობი P`v`v`v`,
AM`u`a`K`vi, m`v`M`v`t`bi Dbაბ|
4. P`v`K`v`i`t`q`T`l Dbაბ (Career development): ukv`v`K l Ab`vb`t`i P`v`K`v`i` t`q`T`i
Dbაბ mnvqK ev cღ`u`Z`g`-K uelq ev t`q`T`l |
5. e`w`3`M`Z Dbაბ (Personal development): e`w`3`M`Z Dbაბ cwi Kíbv, Av`š`te`w`3`K
m`u`t`K`Ges e`w`3`i uerfb`e`w` t`K`i u`e`K`v`k BZ`w` |

1. ԸՔԻՅ Z KգրԾԲԲԳԲ ԸՔԻՅԳԳ մԻՎԻ YZ ԸՅԾՅԵԲ ԸՅԻԲ Ges ԻԿՊԻԿԻ՝ Ի ԸՅԻԲ՝ ԻՂԳԻ
 նԳ| Ab՝ԻԲ՝ մԻՆԳԿ ԻՎԸԻ՝ Ի K_Վ ԻZԳԲԻՎԻԵ ԻՔՏԻ՝ KԻՎ նԳ ԲՎ| ԻԿՊԻՎ ԸՅԾՅԵԻԲԻ
 մԿՅ ԻՎԸԻ՝ Ի KգրԾԲԲԳԻԲԻ ԸՔԻՅԳԳ AՏԻԲԶ KԻԻZ նԵ|
2. AԻԲԿ մԳԳ ԸՅԾՅԵԻԲԻ ՔԻՆ՝Վ ԵՎ ԻԿՊԻԿԻ KԻՎԽԻՍՍՎ՝Բ ԳՅ՝ՎԳԻԲ ԻՔԻՅ Z ՔԻՆ՝ՎԻ
 մԻԻ_ KգրԾԲԲԳԲ KԻՎԻԻԻԳԻ ԻԵԼԳԵ՝՝ մԻՆԳԱՄԻԸԻՆԳ նԳ ԲՎ| ZԻԲ AԵԿ՝B ԻԼԳՎ
 ԻՎԼԻZ նԵ KգրԾԲԲԳԲ ԻԻԲ ԸՅԾՅԵԻԲԻ Ի KգրԻՔ՝ Ի ՔԻՆ՝ՎԳՆԸԿ նԳ|
3. KգրԾԲԲԳԲ AԻԲԿ ԻՊԻԻԻ մԻԻԻ՝ Թ ԲՆԻZԳՎՎ, KգրԻՊ Ի KգրԸՔԻՅԳԳ AԲՅՎԻԻ ԸՈՐ ՔԻՅ Z
 նԳ ԲՎ|
4. KգրԾԲԲԳԲ ԸՈՐ ԿԻՎ ԸՅՎԳԻԲ AԻԲԿ ԻՊԻԻԻ մԻԿՆՈ՝ Ե՝ՎՅԵԼՔԻԿ RԻՈZ KԻՎ նԳ ԲՎ|
 ԸԻՅ ZԻ՝Ի ԳԻ՝՝ ԻՊZԻԵՎՎ Ի GԿՎZԻՎԻ AԲԵ ԸՈՐ ՎՊԻZ նԳ ԻՎ KգրԾԲԲԳԻԲԻ
 , YMZԳՎԻԿ ԸԻՎԵZ KԻԻ |
5. ԳՅ՝ՎԳԲ KգրԾԲԲԳԲ ԸՔԻՅԳԳ AԵԻ՝Չ՝՝ Ask| A_P AԻԲԿ ԻՊԻԻԻ ZԻՈՆԻՈ KԻԻ KգրԾ
 ԲԲԳԲ KԻՎԻԳ MԻՔZ նԻՅ Ի ԳԻ ԳՅ՝ՎԳԻԲ , ԻՅԻՅ ԻՂԳԻ նԳ ԲՎ| AԵՎԻ ԻՎ՝ Ի ԵՎ
 ԳՅ՝ՎԳԲ KԻՎ նԻԳ _ՎԻԿ, ԸՅԻՅ ԸՅՎԸՅ KԻՎ R յՎՄԻԻԲԻ ԻՊԻԻԻ ԻՂՎ ԻՎԳ Ը՝ՎՄԻԲZՎ|
 GՈՐՈՎ KգրԾԲԲԳԲ KԻՎԻԻԳԻ ԸՅՎԸՅ ԳԻՅՄԻՍ ԳԻ ԻՊԻԻԻ ԻՂԳՉ մԳՎՎ|

AZGe ԻԿՊԻՎ ԸՅԾՅԵԻԲ Ի_ՎԻ_ , ԻՅԻՅԻ մԻԻԻ_ KգրԾԲԲԳԲ KգրԻՊ AՎԻԳՎԻԲ KԻՎ ԸՅՎԻԲԲ|
 GԿՎՄ ԸԲԻZ Ges , YMZ ԳՎԲՄՍՍԲԸ KգրԾԲԲԳԲ KԻՎԻԳ AՎԻԳՎԻԲ KԻԻZ նԻՅ KգրԾԲԲԳԲ
 KԻ, ԳԻ ԸԻԻԿ՝, ԸՈՐ ԻՎՎ, ԻԵԼԳ, , ԻՅԻՅ ԳԵՍ մԻԳՎԵՂՎԻ մՍՍԻԿ՝RԻՎԻ ԸՅՎԻԲԲ| ԵZԳՎԲ
 ԸՎԻՎ KգրԾԲԲԳԻԲ Գ մԿՅ ԻԳՏԻՅ K ԻՂՎ մՍՍԻԿ՝Z AՎԻՅՎԲԻ ՎՅԻԸԻ նԻԳԳՉ ԻՎ
 ԻԿՊԻՎԻԻԻԻ D՝Ք ԸԻՊԳԻ ԻԿՊԻՎ_ՎՎԻՄԻԵ ԳԳ GW ԸԻԿՊԻՎ_ՎՎ Ի AՎԻ Ի KԻՎ՝ՊԻZԻ
 ԸԲԲԳԻԲ մԻՆԳԿ նԵ|



ԸՎԻՎԵԻ ԳՅ՝ՎԳԲ 4.1

A) մԻՎԻԻԲ ԸԵԻ ԸԻԸ

1. KգրԾԲԲԳԲ ԵՅ ԻZ KԻ ԵՏՎԳ ?
2. KգրԾԲԲԳԲ Ges KգրԸԻԿՊԻԻԻ ԸՎ_Ք՝՝ KԻ ?
3. KգրԾԲԲԳԲ ԸՔԻՅԳԳ KԻՎ՝ Ի AՏԻԲԶ KԻՎ ԸՅՎԻԲԲ ?
4. ԻԲԸՍԲ Ի ԳՎԻԿԻ ԳԻZ KգրԾԲԲԳԻԲԻ ԸԻԻԿ՝, ԻՅՎ ԵՊԻՎ KԻԲԲ|
5. ԸՔԻՅ Z KգրԾԲԲԳԲ ԸՔԻՅԳԳ ՔԻՆՍ մԻԳՎԵՂՎԻ ԸԻՅ Լ KԻԲԲ|
6. KգրԾԲԲԳԲ ԸՔԻՅԳԳ ԸՅԾՅԵԻԲԻ ԸԲԲԳԻԲ ԻԿԲԻԵ մԻՆԳZՎ KԻԻZ ԸՎԻԻ ?

AՎ) ԻՔՎԳՅԻԿ ԸԻԸ

1. KգրԾԲԲԳԲ KԻՎԿ ԵԻՅ ? ԻԿՊԻՎԻԻԻԻ KգրԾԲԲԳԻԲԻ ԻԵԼԳ, ԻՅՎ KԻ նԻZ ԸՎԻԻ ?
2. KգրԾԲԲԳԻԲԻ , ԻՅԻՅ ԵՎԼ՝Վ KԻԲԲ| ԸՔԻՅ Z KգրԾԲԲԳԲ ԸՔԻՅԳԳ մԻԳՎԵՂՎԻ Ges
 `ԻԻԿԻԻԻԻ ԸԸՎԳ ՎՅԻԼԻԻ|

cW 4.2

Kgx[®]Dbəb cūquvi mdj Zvi Dcv`vb I chiq

[Success Factors and Stages of Staff Development Process]

Dt`ik`

GB cW tk`l Avicvb –

- Kgx[®]Dbəb cūquvi mdj Ges KvhRix Kivi Dcvq Dtj L KitZ cvi`teb Ges
- Kgx[®]Dbəb cūquvi chiqmgn eYb`v KitZ cvi`teb|

cūg cvfvi AvtjvPbv t`tk Avgiv Kgx[®]Dbəb cūquvi KtqKūw mīgve×Zv m`útk[®] tRtbiw| Gme mīgve×Zv Kgx[®]Dbəb cūquvi KvhRvvi Zvq FYvZK cFvte tdtj hv Gi j`ŋ` ARtbi GKūw eo Ašivq| eZg`vb cvfV Kgx[®]Dbəb cūquvi mdj Zvi KtqKūw Dcvq ev kZ[®]Ges chiqmgn Avtj wPZ ntqtQ| tmBmvt_ Kgx[®]Dbəb cūquvi dj cūki`y Kgm`úv`b gj`vqtbi _iazi m`útkZ AvtjvPbv AšifZ ntqtQ| G_ tji vi h_v_`Abvvi Y GKūw mdj Kgx[®]Dbəb cūquvi Rb` Acvvi nvh`ŋ

Kgx[®]Dbəb KvhRig mdj Zvi Dcvq

**ukŋv cūZōv`bi
KvhRvvi Zv eŋ`K`i`y
MpxZ KgRv`Ūi
Avet`Q` Ask**

1. Kgx[®]Dbəb Kgm`p`k ukŋv cūZōv`bi KvhRvvi Zv eiaZKi`yi j`ŋ` MpxZ wevfbae Kgm`pi Avet`Q` Ask wntmte wetePbv KitZ nte| Gi gva`tg cūZōv`bi KgPZ e`w`em[®] wekiz ukŋKt`i tckvMZ Dbəbtbi cūZ bRi w`tZ nte| Zte GK_v mZ` th, tKej gv`l Kgx[®]Dbəb cūquvi GKūw ukŋv cūZōv`bi KvhRvvi Zv`K m`úv`ŋ`c w`w`ōZ KitZ cvti bv| Gi Rb` cūqvRb Avil wevfbaeitbi Dt`vM| Zte Kgx[®]Dbəb Gi Ab`Zg|

**Kgx[®]Dbəb cūquvi
j`ŋ` j` nte ukŋK
I Ab`vb` mKj
÷vde`**

2. Kgx[®]Dbəb cūPón tKej gv`l ukŋK ev cūZōv`bi _wKtqK e`w`i Rb` MpxZ ntjB nte bv, eis cūZōv`bi mKj Kgx[®] Rb` Gi m`ŋ`vM m`w`o KiZ nte| MZvbMvZK Kgx[®]Dbəb Dt`v`Mi GKūw mgm`v nj GtZ cūvbZ ukŋKt`i DbəbtK _iazi cūvb Kiv nq| hv`l ukŋv cūZōv`b hviv ukŋv`vb KvthP mvt` mivmvi RvōZ Zt`i tckvMZ Dbəb AvakZi thšv`K, Z_vvc cūZōv`bi Ab`vb` mrvqK ÷vdt`i Kg[®]ŋZv eŋ`i`l cūqvRb itqtQ| Kvi Y ukŋv cūZōv`bi KvhRig ev`lvq mgteZ cūPóni gva`tg ntq_v`K| Avi ZvB ukŋv cūZōv`b cKZ. ukLb mgvR I cvv`w`Z `Zvi KitZ ntj KgPZ mKj`k`ŋZvi mvt` fūgKv cvj`tbi m`ŋ`vM w`tZ nte|

**cūZōv`bi wR`^Kgx[®]
Dbəb cvv`K`i`bv
_vKte**

3. Kgx[®]Dbəbtbi Rb` ukŋv I ukŋvmsikō mKj cūZōv`bi wR`^Kgx[®]Dbəb cvv`K`i`bv _vKte| GiU wZb chiq wef`3 ntZ cvti:
- cūZōv`bi GKūw wR`^Kgx[®]Dbəb bvxZ _vKte hv`Z Kgx[®]Dbəbtbi Dt`ik` m`w`o`ŋ`f`vte eiv`Z _vKte| Kv`i Rb` G aitbi Dt`vM MpxZ nte tmUvI Dtj - L _vKtZ nte|
 - Kgx[®]Dbəb bvxzi wfv`ÉtZ GKūw m`w`o`ŋ` Kgx[®]Dbəb Kgēvvi K`i`bv cūv`Z nte hv`Z we`vvi Z Dt`ik` Ges ukLbdj (learning outcomes) weeZ _vKte|

Kgx®Dbq̄b c̄uqv̄i ch̄iq̄

GK̄uJ ev`éagx̄i ḡvbm̄úbr̄Kgx®Dbq̄b Kḡēwi Kí b̄v M̄h̄Y I ev`évaq̄t̄bi ḡva`tḡ ̄k̄ŕŕK I Ab`vb̄ ÷vd̄t`i tck̄v̄MZ `ŕŕZ̄vi Dbq̄b I c̄ŕZ̄ôv̄t̄bi ḡv̄t̄b̄v̄b̄q̄b m̄ǣ| Kgx®Dbq̄b K̄vh̄ŕ̄ig ev`évaq̄t̄bi ̄v̄Z̄b̄uJ ch̄iq̄ īt̄q̄t̄Q| Ḡ, t̄j v̄ nj – (1) P̄v̄n̄ v̄ ̄v̄b̄īf̄c̄Y, (2) c̄k̄ŕŕY c̄ŕv̄b Ges (3) ḡj`v̄q̄b I dj̄veZ̄B̄ (feedback)|

Kgx®Dbq̄b K̄vh̄ŕ̄īt̄gi G ch̄iq̄, t̄j v̄ ci`ú̄i m`ú̄K̄ŕŕŕ Ges Ḡ, t̄j v̄ c̄ŕZ̄ôv̄b I ÷vd̄t`i Dbq̄t̄b GK̄uJ av̄i v̄ev̄n̄K Kḡm̄P̄ c̄ŕŕq̄t̄b m̄n̄v̄q̄K| ̄v̄t̄P G ch̄iq̄, t̄j v̄ Av̄t̄j ̄v̄PZ̄ nj |

P̄v̄n̄ v̄ ̄v̄b̄īf̄c̄Y

Kgx®Dbq̄b K̄vh̄ŕ̄īt̄gi īīt̄Z̄ Gi P̄v̄n̄ v̄ ̄v̄b̄īf̄c̄Y Kīt̄Z̄ n̄t̄e| Kgx®Dbq̄t̄bi P̄v̄n̄ v̄ ̄v̄b̄īf̄c̄Yi ̄v̄v̄f̄b̄ǣDc̄v̄q̄ īt̄q̄t̄Q| Gi ḡt̄a` Ab`Z̄g n̄t`Q ÷vd̄t`i Kḡm̄úv̄`b ḡj`v̄q̄b hv̄ m̄ú̄t̄K̄cēZ̄r̄BD̄v̄t̄U Av̄t̄j v̄P̄b̄v̄ K̄iv̄ n̄t̄q̄t̄Q| Kḡm̄úv̄`b ḡj`v̄q̄t̄b c̄ŕB̄ Z̄t̄`i ̄v̄f̄v̄É̄t̄Z̄ Kgx®Dbq̄t̄bi P̄v̄n̄ v̄ ev̄ j̄ŕŕ ̄v̄b̄āŕŕY dj̄c̄h̄-n̄q̄| Kḡm̄úv̄`b ḡj`v̄q̄t̄bi c̄īk̄v̄c̄v̄k̄ GK̄uJ ŐP̄v̄n̄ v̄ ̄v̄b̄īf̄c̄Y ̄v̄el̄q̄K c̄ŕk̄ǣĒwi K̄vīŕ̄ ḡva`tḡ Ḡ m̄ú̄m̄K̄Z̄ Z̄` m̄s̄M̄p̄x̄Z̄ n̄t̄Z̄ c̄v̄t̄i, hv̄ b̄v̄n̄K P̄v̄n̄ v̄ ̄v̄b̄īf̄c̄Yi GK̄uJ Av̄Z̄wi³ D̄rm̄ ̄v̄n̄t̄m̄t̄e K̄iv̄R̄ Kīt̄e| ḠQ̄v̄ov̄ Kgx®Dbq̄t̄bi P̄v̄n̄ v̄ ̄v̄b̄īf̄c̄Y c̄ŕZ̄ôv̄t̄bi ÷vd̄t`i m̄n̄v̄q̄Z̄v̄ I c̄īv̄ḡk̄M̄h̄Y Kīt̄Z̄ n̄t̄e|

c̄k̄ŕŕY c̄ŕv̄b

ḠuJ Kgx®Dbq̄t̄bi c̄h̄v̄b ch̄iq̄| G ch̄iq̄ ̄v̄v̄f̄b̄ǣK̄vh̄ŕ̄j̄v̄t̄ci ḡva`tḡ m̄īv̄m̄wi Kgx®Dbq̄t̄bi D̄t`v̄M̄ M̄p̄x̄Z̄ n̄q̄| Ḡme K̄vh̄ŕ̄j̄v̄t̄ci Aš̄l̄f̄Z̄ īt̄q̄t̄Q ̄v̄v̄f̄b̄ǣīt̄bi c̄k̄ŕŕY c̄x̄v̄Z̄ hv̄i Ab`Z̄g nj Ask̄M̄h̄Y Ges Av̄j̄v̄c-Av̄t̄j v̄P̄b̄v̄| ḠQ̄v̄ov̄ Kgx®Dbq̄t̄bi R̄b` īt̄q̄t̄Q Av̄i I Ab`vb̄` c̄x̄v̄Z̄ th̄, t̄j v̄ Ḡ t̄ŕŕŕĪ e`ēǖZ̄ n̄t̄Z̄ c̄v̄t̄i| th̄gb- K̄vh̄®AveZ̄B̄ (job rotation), ŕŕḡZ̄v̄ Ac̄ŕ (delegation), m̄v̄ḡv̄q̄K̄f̄v̄t̄e `v̄q̄Z̄j̄ c̄ŕv̄b, c̄t`v̄b̄v̄Z̄, work shadowing Ges c̄ŕZ̄ôv̄t̄bi m̄v̄t̄_ Kḡm̄K̄ m̄sh̄ŕ̄ K̄t̄i t`l̄q̄v̄ (industry placement) BZ`w̄ | Ḡme c̄k̄ŕŕY Kḡm̄P̄t̄Z̄ c̄ŕZ̄ôv̄t̄bi Af`š̄l̄īx̄Y I ēīn̄:m̄ú̄t̄`i c̄v̄i c̄ŕŕe`en̄v̄t̄i ī m̄t̄h̄v̄M̄ īt̄q̄t̄Q| ḠQ̄v̄ov̄ Av̄i I ̄v̄k̄Q̄ym̄ú̄i-K̄ Kḡm̄P̄i ḡva`tḡ Kgx®Dbq̄t̄bi Z̄_v̄ c̄k̄ŕŕŕYi c̄ŕP̄óv̄ t̄b̄l̄q̄v̄ h̄v̄q̄| th̄gb- Kḡm̄k̄v̄ei, t̄m̄v̄ḡb̄v̄i, Ab` c̄ŕZ̄ôv̄b c̄v̄i`k̄B̄, t̄k̄ŕŕK̄ŕŕ ch̄ŕeŕŕY, M̄t̄el̄Yv̄ BZ`w̄ | Z̄t̄e Ḡ KḡēŕP̄óv̄, ̄v̄j̄ m̄v̄_ŕ̄ n̄t̄Z̄ n̄t̄j̄ Z̄v̄ Aek`B̄ ̄v̄k̄ŕŕv̄ c̄ŕZ̄ôv̄t̄bi P̄v̄n̄ v̄ Ges Aš̄l̄b̄ŕ̄N̄Z̄ j̄ŕŕ I D̄t̄īt̄k`i ̄v̄f̄v̄É̄t̄Z̄ c̄v̄i P̄v̄j̄ Z̄ n̄t̄Z̄ n̄t̄e hv̄ Kgx®Dbq̄b Kḡm̄P̄t̄K̄ t̄h̄š̄v̄³ K̄ ̄v̄f̄v̄É̄i D̄ci c̄ŕZ̄v̄öZ̄ Kīt̄e|

ḡj`v̄q̄b I dj̄veZ̄B̄

Kgx®Dbq̄b K̄vh̄ŕ̄īt̄gi ZZ̄x̄q̄, īǣZ̄c̄ŕŕ`li nj Gi ḡj`v̄q̄b Ges dj̄veZ̄B̄| ḡj`Z̄ ḠuJ Kgx®Dbq̄b Kḡm̄P̄i Av̄ēi`ŕ̄ŕēAsk̄| Kgx®Dbq̄b c̄ŕP̄óv̄ t̄K̄gb nj, KZ̄Uv̄ dj̄c̄h̄-n̄j, j̄ŕŕ I D̄t̄īk` AR̄ŕ̄ ḠuJ KZ̄Uv̄ m̄n̄v̄q̄K Ges Av̄i K̄x̄ Kīt̄j̄ Gi, ȲMZ̄ḡv̄b ēp̄x̄ t̄c̄Z̄ BZ`w̄ c̄k̄ŕŕŕYi D̄Ēi L̄ŕ̄ t̄c̄t̄Z̄ n̄t̄j̄ ḡj`v̄q̄b `īK̄vi| ̄v̄t̄k̄l̄Z̄ hv̄i v̄ ḠuJ c̄v̄i P̄ij̄ b̄v̄i m̄v̄t̄_ m̄s̄v̄k̄- ó īt̄q̄t̄Qb Z̄v̄t`i R̄b` Ḡ c̄k̄ŕŕŕYi D̄Ēi R̄v̄b̄v̄ R̄īǣi | Ḡ āīt̄bi ḡj`v̄q̄t̄b ̄v̄v̄f̄b̄ǣīt̄bi c̄ŕuqv̄i e`ēǖZ̄ n̄t̄Z̄ c̄v̄t̄i Ges Z̄v̄ Av̄b̄v̄ḡv̄m̄b̄K̄ Av̄t̄j v̄P̄b̄v̄ t̄_ŕ̄K̄ K̄v̄v̄t̄ḡv̄ēx̄ Av̄t̄j v̄P̄b̄v̄ n̄t̄Z̄ c̄v̄t̄i | Av̄ēi c̄ŕk̄ǣĒwi K̄v̄ c̄ŕŕq̄b K̄t̄i I Kgx®Dbq̄b Kḡm̄P̄i ̄v̄b̄v̄ŕ̄ j̄ŕŕ I D̄t̄īt̄k`i AR̄ŕ̄ ḡj`v̄q̄b K̄iv̄ h̄v̄q̄| ḡj`v̄q̄t̄b c̄ŕB̄ ̄v̄d̄Wēv̄K̄ M̄h̄Y I ev`évaq̄b Kgx®Dbq̄b K̄vh̄ŕ̄īt̄gi j̄ŕŕ AR̄ŕ̄ Ges ̄v̄k̄ŕŕv̄i, ȲMZ̄ḡv̄b ̄v̄b̄v̄öZ̄K̄īt̄Y, īǣZ̄c̄ŕŕ`ŕŕḡK̄v̄ c̄v̄j̄ b̄

Kti | 𐌺Š`yL RbK ntj I mZ` th, Kgr°Dbq̅tbi Rb` weifbaekgfr̅P MpxZ ntj I Gi KihR̅wi Zv gj`vq̅tbi 𐌺 KuU AþK t¶¶t̅ Aetnij Z | Averi tKvb tKvb t¶¶t̅ gj`vq̅tbi Kiv ntj I c̅B̅ 𐌺We`vK KvR j vM̅t̅bri c̅P̅v̅n̅ tbB ej t̅j B P̅t̅j | dt̅j Kgr°Dbq̅tbi c̅P̅v̅n̅ c̅Z`𐌺 dj j vtf e`nq Ges Zv mgq, A_°I k̅gi AcP̅t̅qi m̅j̅h̅M̅ m̅j̅o̅ Kti | G 𐌺 KuU weþeP̅v̅q̅ t̅i̅L̅ th tKvb Kgr°Dbq̅tbi Kvh̅p̅g gj`vq̅tbi Rb` avivem̅K c̅p̅u̅q̅v̅ M̅h̅Y̅ KiþZ n̅t̅e | Avi GB gj`vq̅tbi n̅t̅e Kgr°Dbq̅tbi b̅x̅Z, c̅w̅i̅ K̅i̅ b̅v̅, t̅K̅Š̅k̅j̅, c̅x̅w̅Z Ges c̅p̅u̅q̅v̅i | A_° Kgr°Dbq̅tbi c̅P̅v̅n̅ c̅i̅Z̅i̅U̅ c̅`t̅¶̅t̅ci̅ gj`vq̅tbi c̅p̅q̅v̅R̅b̅x̅q̅Z̅v̅ i̅t̅q̅t̅Q̅ | Kgr°Dbq̅tbi Kgr̅P̅i̅ , YMZg̅v̅b̅ 𐌺w̅i̅o̅Z̅ KiþZ ntj gj`vq̅tbi I dj veZ̅t̅bi tKvb weK̅i̅ tbB |

Kgr°Dbq̅tbi c̅p̅u̅q̅v̅i KihR̅wi Zv 𐌺f̅P̅ Kti h_vh_ c̅w̅i̅ K̅i̅ b̅v̅ c̅v̅q̅b̅ I ev`ev̅q̅t̅bi D̅c̅i̅ | tmB m̅v̅t̅_ KihR̅ix̅ Kgr°Dbq̅tbi c̅p̅u̅q̅v̅i `e̅w̅k̅o̅`_t̅j̅v̅i̅ A̅b̅y̅i̅Y̅ Kgr°Dbq̅tbi KihR̅wi Zv̅t̅K̅ e̅u̅j̅v̅s̅t̅k̅ ev̅o̅v̅t̅Z̅ c̅v̅t̅i̅ | Kgr°Dbq̅tbi c̅p̅u̅q̅v̅i th 𐌺Z̅b̅i̅U̅ `𐌺K̅Z̅. Ges avivem̅K ch̅q̅ (P̅w̅n̅`v̅ 𐌺b̅i̅f̅c̅Y̅, c̅l̅k̅¶̅Y̅ Ges gj`vq̅tbi I dj veZ̅t̅) i̅t̅q̅t̅Q̅ tm, t̅j̅v̅i̅ h_v_°A̅b̅y̅i̅Y̅I̅ Kgr°Dbq̅tbi Kgr̅P̅i̅ mdj ev`ev̅q̅t̅bi Rb` Ac̅w̅i̅n̅v̅h̅¶̅ Av̅g̅v̅t̅`i̅ t̅`t̅k̅ 𐌺¶̅v̅ m̅s̅w̅k̅o̅ c̅l̅Z̅o̅v̅b̅_ t̅j̅v̅t̅Z̅ Kgr°Dbq̅tbi th m̅K̅j̅ D̅t̅`v̅M̅ M̅p̅x̅Z̅ n̅t̅q̅_v̅t̅K̅ tm, t̅j̅v̅t̅Z̅ Gi h_v_°A̅b̅j̅x̅j̅ b̅ ev̅A̅b̅x̅q̅ | Gi g̅v̅a̅`t̅g̅ G̅K̅w̅`t̅K̅ th̅g̅b̅ Kgr°Dbq̅tbi c̅p̅u̅q̅v̅i , YMZg̅v̅b̅ i̅¶̅¶̅Z̅ n̅t̅e, tmB m̅v̅t̅_ 𐌺¶̅v̅ I 𐌺¶̅v̅ e`e`v̅i̅ , YMZ g̅v̅t̅b̅v̅q̅b̅ 𐌺w̅i̅o̅Z̅K̅i̅Y̅ m̅=̅e̅ n̅t̅e |



c̅v̅t̅V̅E̅i̅ gj`vq̅tbi 4.2

A) m̅s̅w̅j̅B̅ D̅E̅i̅ c̅k̅æ

1. Kgr°Dbq̅tbi c̅p̅u̅q̅v̅i j ¶̅`j̅ K̅v̅i̅v̅?
2. Kgr°Dbq̅tbi c̅w̅i̅ K̅i̅ b̅v̅i̅ ch̅q̅_ t̅j̅v̅ K̅x̅?
3. Kgr°Dbq̅tbi b̅x̅Z, c̅w̅i̅ K̅i̅ b̅v̅ I Kgr̅P̅i̅ c̅v̅q̅t̅b̅ tKvb tKvb we̅l̅q̅ we̅t̅e̅w̅P̅Z̅ n̅l̅ q̅v̅ c̅p̅q̅v̅R̅b̅?
4. Kgr̅P̅i̅`b̅ gj`vq̅t̅b̅t̅K̅ Kgr°Dbq̅tbi Kgr̅P̅i̅ c̅w̅i̅ P̅v̅j̅ b̅v̅i̅ gj`ev̅b̅ R̅j̅j̅ v̅b̅x̅ ej̅v̅ n̅q̅ t̅K̅b̅ – e`v̅L̅`v̅ K̅i̅ a̅b̅ |
5. Kgr°Dbq̅tbi c̅p̅u̅q̅v̅i ch̅q̅ K̅q̅i̅U̅ I K̅x̅ K̅x̅?
6. Kgr°Dbq̅tbi P̅w̅n̅`v̅ 𐌺K̅f̅v̅t̅e̅ 𐌺b̅i̅f̅c̅Y̅ K̅i̅v̅ h̅v̅q̅?
7. Kgr°Dbq̅tbi c̅p̅u̅q̅v̅i gj`vq̅tbi I dj veZ̅t̅bi̅ , i̅a̅z̅; e`v̅L̅`v̅ K̅i̅ a̅b̅ |

Av) i̅P̅b̅v̅j̅-K̅ c̅k̅æ

1. Kgr°Dbq̅tbi ej̅t̅Z̅ K̅x̅ e̅S̅v̅q̅? Kgr°Dbq̅tbi Kvh̅p̅g mdj KiþZ ntj tKvb tKvb we̅l̅t̅q̅ m̅t̅P̅Z̅b̅_v̅K̅t̅Z̅ n̅t̅e Ges t̅K̅b̅?
2. Kgr°Dbq̅tbi Kgr̅P̅i̅ ev`ev̅q̅t̅bi ch̅q̅_ t̅j̅v̅ A̅v̅t̅j̅v̅P̅b̅v̅ K̅i̅ a̅b̅ | G̅t̅¶̅¶̅t̅ we`g̅v̅b̅ m̅x̅g̅v̅e̅x̅Z̅v̅_ t̅j̅v̅ K̅x̅?

Qvqv c×wZ (Shadowing): G c×wZtZ tKvb ግግK hw` GKwU bZb wltq Ávb I wtkl AwfÁZv ARፀ Ki tZ Pvb Zte ZፏK H wltq AwfÁ GKRb ግግtKi mvt_ tkYxKtፑ mshፏ Kti w`tq H wltqi Ávb I `ፑZv ARፀ Ki tZ mrvh` Kiv nq/ D`vniY`tfc, cፐwK we`ij tqi GKRb bZb ግግK avivwK gj`vqb c×wZ m°útk[©] Rvb tZ Pvb, Gtፑtፑ avivwK gj`vqb wltq AwfÁ Ges cፏፑፑYcፐፐ GKRb ግግtKi mvt_ ZፏK msuk- ó Kti G wltq cፏፑፑY t`lqv hvq/ tKej bZb ግግK bb, cjuZb ግግKi vI G c×wZtZ bZb tKvb wltq Ávb I `ፑZv ARፀ Ki tZ cvtib/

Kihፑw (Job sharing): G tKSkj wU Qvqv c×wZi gZB/ Zte Gi Kihፑwiv Zv AvI tenk/ GtZ GKRb AwfÁ ግግtKi mvt_ GKwU tkYxtZ Avti KRb Kg AwfÁZvm°úbe ev bZb ግግKtK KivR Ki tZ w`tq Zuí tckwMZ `ፑZv evovtbr nq/ cፐwK chፑፑ UxguUwPs Gi tፑtፑ GiU tenk e`eüZ nq/

chፑፑY I wtkፑY (Observation and analysis): GiU Qvqv c×wZ Ges Kihፑw c×wZi ewazifc/ Zte GiU wtkl GKwU `ፑZv ARፑbi Rb` AwaKZi Dcፑhvmx/ thgb- tKvb GKRb ግግK hw` `jMZ KivR wkfite cwipvjbv Ki tZ nq Zv Rvb tZ AvMöx nb ev tKvb wtkl wLb-tkLv tbr c×wZ m°útk[©] ፑZv ARፀ Ki tZ Pvb Zte H wltq AwfÁ GKRb ግግtKi Kvk chፑፑY I wtkፑY Ki tZ w`tq Zuí H wltqi `ፑZv ewxi e`v Kiv hvq/

Bidding Initiative: G c×wZtZ ግግKt`i cፐZöitbi Pwv`vbyvqx wevbwewltq `ftgqv`x Df`wM MötY DrmwvZ Kti Zፏ`i tckwMZ Dbፑbi mፑhvm mwፐ Kiv nq Ges GRb` Zፏ`i tK fivZv t`lqv nq/ D`vniY`tfc, GK`j ግግKtK we`ij tqi Kgx[©] Dbፑb Kvhፑፑ gj`vq tbi `wqZ; w`tq Zv`i G KvRi `ፑZv evovtbr thtZ cvtib/ Zte mkj tፑtፑB fivZv e`v Ki tZ nte Ggb tKvb ewa`evaKZv tbB/ AtbK ግግK AvtQb hviv tKvbi Kg Aw`ፑ mፑav QvovB tKej gvĠ KgፑፑZv ewxi `ፑ`G aitbi Df`vMi mvt_ RwoZ nq `vtKb/

`ftgqv`x Pwፑ (Short term contracts): Gi gva`tgi Af`šlixY Kgx[©]Dbፑb m°e/ GtZ msvፑፑB mgፑqi Rb` GKRbtK mፑbw`ፀ `wqZ; i fivZv t`lqv nq/ thgb- GKRb ግግKtK we`ij tqi QvĠ fivZ`msvፑፑ wltq GK eQtii `wqZ; t`lqv hvq/ Gfite e`vcbv wltq GKRtbi AwfÁZv evovtbrv KvR G c×wZwU e`eüZ nq tZ cvtib/

civgk[©]Zv I eÜz figKv (Mentoring and buddy role): GKKfite Kgx[©]Dbፑb cፏwqi Avti KuU w`K nj GiU/ GtZ GKRb AwfÁ ግግKtK bZb GKRb ግግtKi Rb` civgk[©]Zvi figKv cvjb Ki tZ ejv nq/ GtZ civgk[©] ግግtKi AvZፑekvm ewto Ges bZb ግግtKi tckwMZ Dbፑb LyB KvR Avtm/ GiU civgk[©]Zv ግግK i bZb ግግK Dftqi tckwMZ `ፑZv ewxi `ፑ i Kihፑix Dcvq/

cuieZBkj `wqZ; (Rotating responsibility) : G cōLqvī we`'ij tqi weifbæ`wqZ; thgb- jvBteix cui Pij bv, `čj g`vMniRb tei Kiv, ugiUs -Gi m×vš'ij Lv l welqe` Dc`vcb, mfvcwZZ; Kiv BZ`w `wqZ; chřqμtg weifbRbčK t`lqv nq| Gw uk`qKč i mš cōZfv weKvčki Abb` Dcvq Ges Kgx`Dbqčbi GKw mnRzG c×wZ|

mgvtek (Assembly): we`'ij tqi mKj uk`qčKi Dci chřqμtg mgvtek AvtqvRčbi `wqZ; Ac` Kči l Kgx`Dbqčb Kiv hvq| Gw AwfÁZv ARčbi GKw DEg Dcvq| KviY uk`qKe` hw`l tkYvKčq AvZwekčmi mvt_ cvV t`b Z_wic G`i AčččKB epr `kčKi (mnKgx`ev uk`qiv_x) mvgčb fq ev A`w`' teva KičZ cvčib| Gčqčč mgvtek AvtqvRčbi `wqZ; uk`qč i gč` AvZwekčm mwpčZ mnvqK nč|

āgY ev wečkl Aa`qb Qv ev bZč uk`qK vbtqm (Sabbatical leave or teacher placement): Gw ukQyv e`qeúj Ges Af msL`K cōZōvb G e`e`v MhY KičZ cvčib | G c×wZčZ uk`qKčK tKvb GK ev GKwčK wčtq Aa`qčbi Rb` wv` š mgčqi Qv t`lqv nq Ges G mgčqi Rb` bZč uk`qK vbtqm t`lqv hvq| Avgt` i t`čk wekte`'ij q_čj včZ G c×wZ Pij yitqčQ| G c×wZčZ tckvMZ Dbqčb AvMhč uk`qKe` DcKZ.nčZ cvčib Ges bZč wLb l AwfÁZv Zv i DbwZi mčhvM t`q|

Co-opting : Gw tKej Kgx`Dbqčb bq, uk`qč i AvZwekčm epxčZl mnvqK| GčZ wefvčmi cōvb ev tKvb wčtqi AwfÁ uk`qčKčK (senior management team) GK GKw wv` š mgčqi Rb` tKvb e`e`vcbv `čj KvR Kivi Rb` weččb Kiv nq| Gi dtj H e`e`vcbv Uxg GKw tK uk`qč i AwfÁZv t`čK DcKZ.nq, Ab`w tK weččZ uk`qK wfbz i tčqvcčU KvčRi AwfÁZvi gvačg e`e`vcbv wčtq `q nč DčVb|

Af`šiv KgřvčU RivZ ni qv (Involvement in INSET): we`'ij tqi Pw`v Abhvqx wv`^Kgx`Dbqčb Kvčřg cui Pij bqv we`'ij tqi uk`qč i RivZ Kči Zvč i e`w`MZ l tckvMZ Dbqčb Kiv hvq| G c×wZčZ we`'ij tqi Kgx`Dbqčb cui Kiv bv cčqčbi ci ÷vde` t`Qvčqgi wfvččZ weifbæččk`qY cte`AskMhY Kčib Ges Zvč i AwfÁZv l `qZvčK Ab`v` ÷vč i mvt_ fvM Kči tbb| th me uk`qv cōZōvčb gvčS gvčS weifbæwčtq ččk`qY KgřvčPi e`e`v ičqčQ tmlvčb G c×wZ fvj fvče cčqvM Kiv hvq| GčZ weifbævčd m`m` weifbæwčtq ččk`qY t`b| hLb GKRB Dc`vcb Kčib ZLb Ab`v` ÷vč m`m`iv Kvčřix tmkčb AskMhY Kčib|

thš_ we`'ij q Dč`wM (Joint school venture) : we`'ij tqi thš_ Dč`wM Kgx`Dbqčbi GKw fvj Dcvq| GKw cōZčex we`'ij tqi tKvb GKw wčtq fvj `qZv včtčZ cvčib hv nqčZv Ab` GKw cvk`Zv`čj i tčb| Gčqčč th we`'ij tqi H wčtq `qZv AvčQ tmlU Ab` we`'ij tqi mvt_ AwfÁZv wčbgtqi gvačg H we`'ij tqi H wčtq `qZv epxčZ mnvqK fvqKv cvj b Kči |

Ab` we`'ij q cui`kš (Visiting other schools) : hw` tKvb we`'ij tqi tKvb wčtq wečkl AwfÁZv Ges `qZv včK Zč Zv t`čK GKw cōZčex we`'ij q DcKZ.nčZ

citi | uKS' Ggb nřZ citi th, c0qvRbix mgtqi Afvte H ue`ij tqi ctq tKvb
c0kqY Kg0P AvtqvRb Kiv m0e nř"Q bv| GtqTt ueKi intmte H ue`ij tqi
GKRb ukqK AwfAZvm0ub0ae`ij qiu cwi`k0 Kti metkl AwfAZuU AR0 KiřZ
citi b Ges cieZixZ ubřRi ue`ij tqi wdti Gtm Ab`vb`ř i c0kqY wřZ citi b|

Kg0AwfAZv (Work experience): Kg0AwfAZvi mřhvM ukqKř i gj`evb Ařf0
m0řZ Ges Kg0qZvi c0vřti mnvqK nřZ citi | G cxuřZ GKRb ukqKřK
nřZKj řg uewf0eKvR Kivi mřhvM c0vb Kři Zvi tckvMZ `řZvi Db0bmvab Kiv
hvq| D`vni Y`řc, ukqKe, řK ukqřvřg Db0b ev c0vřvK tKvb KřR m0u3 Kiv
hvq| Gfvte Zřř i nřZKj řg AvřZ Ávb ue`ij q Ges e`vřMZ Db0b , iazcY0
řvqKv ivLřZ citi |

vebqg (Exchange): AřbK mgq GKiu ue`ij tqi GK ev GKv0K ukqKřK Ab`
GKiu řij ue`ij tqi mgvřbi cř ubv0 mgtqi Rb` KvR KiřZ wřq AwfAZv
AR0 Kivi mřhvM ř lqv hvq| cieZixZ H ue`ij q řřK AvřZ AwfAZv ubřRi
ue`ij tqi Kgx0Db0b KřR j wMřq ue`ij tqi Db0b c0P0řK MvřZgq Kiv hvq|

Dcvi ewřZ Kgx0Db0b c0řqv, řjv ukqřv c0Z0řbi avivv0K Kgx0Db0b c0P0řK
Av0KZi Kvřřix l kv3kvx KiřZ citi | G, řjv cwi Pvj bvi Rb` řZgb A_0
Rbej c0qvRb tbB| c0Z0řbi m0vřZ m0uřř i gř0B G, řjv cwi Pvj Z nřZ citi |
Avřř i řřki ukqřv c0Z0řbmgřn Kgx0Db0b G c0řqv, řjv mnřRB AvřřZ nřZ
citi |



civřvi gj`vqb 4.3

A) mřvřB DĚi c0ke

1. ukqKř i Rb` Kgx0Db0b m0vřZb řKřkj , řjv Kř?
2. Kgx0Db0b PivqZ cxuřZi m0vřvZv eY0v Ki0b|
3. Shadowing Kř? D`vni Ymn řj Lř|
4. řřřqv x P0ř i gva řg Křfvte ukqKř i tckvMZ Db0b Kiv hvq?
5. Kgx0Db0b c0řqv intmte KgřvM l cwi eZ0kvj `vqZi - G `řři cv`R` řj Lř|
6. Kgx0Db0b řřř thř ue`ij q Dř`vM Ges Ab` ue`ij q cwi`křbi , iazj
e`vL`v Ki0b|

A) iPbřj-K c0ke

1. ukqřv c0Z0řbi Af`řřixY Kgx0Db0b řKřkj , řjv eY0v Ki0b|
2. evřřřřři gva`vřK ue`ij qmgřni ue`gvb GKřřřřřK l A_0vřZK Ae`řq
meřřřřř tevk Kvřřřřř nře Ggb c0řvU Kgx0Db0b řKřkj hvřmnKřři eY0v
Ki0b|

cW 4.4

e`w³ ch⁹q uk⁹qKt` i Kgx⁹Dbq⁹ tK⁹skj
[Personalizing Staff Development Techniques for Teachers]

Dt`ik`

GB cW tk`l Avicb -

□ e`w³ ch⁹q uk⁹qKt` i Kgx⁹Dbq⁹ tK⁹skj i g⁹wj Dtj⁹ K itz cvi⁹teb|

c⁹z⁹ovt⁹ Kg⁹qZ uk⁹qK I Ab`vb`f` i Rb` Kgx⁹Dbq⁹ Kg⁹m⁹ AvtqvRb uk⁹q c⁹z⁹ovt⁹bi Ab`Zg c⁹vb` vqZj| c⁹z⁹ovt⁹bi `f`_B GuU Kiv D⁹WZ| ce⁹Z⁹c⁹v⁹V uk⁹q c⁹z⁹ovt⁹bi ch⁹q M⁹xZe` Kgx⁹Dbq⁹ tK⁹skj ,tjv m⁹u⁹tK⁹Avgiv tR⁹t⁹Q| eZ⁹vb cv⁹V e`w³ ch⁹q uk⁹qKt` i tckvMZ Dbq⁹bi KtqK⁹W g⁹wj m⁹u⁹tK⁹ms⁹t⁹q⁹tc Avgiv AewZ ne|

e`w³ ch⁹q Kgx⁹ Dbq⁹bi g⁹wj

Marczely (1996)-Gi g⁹tZ e`w³ ch⁹q uk⁹qKt`i tckvMZ Dbq⁹bi Rb` w⁹t⁹g⁹ AvUu Kgx⁹Dbq⁹ g⁹wj Ab⁹z n⁹tZ cvi⁹|

- 1| ukLb-tkLvtbv Kv⁹h⁹f⁹u⁹E⁹K Kgx⁹Dbq⁹ (Instruction centred staff development)
- 2| m⁹h⁹w`⁹ c⁹uk⁹qY⁹u⁹f⁹u⁹E⁹K Kgx⁹Dbq⁹ (Focused training staff development)
- 3| m⁹h⁹w`⁹ M⁹tel Y⁹vtK⁹w`⁹ K Kgx⁹Dbq⁹ (Focused research staff development)
- 4| tgav gj`w⁹f⁹u⁹E⁹K Kgx⁹Dbq⁹ (Merit pay staff development)
- 5| w⁹`⁹vj q Dbq⁹tK⁹w`⁹ K Kgx⁹Dbq⁹ (School improvement staff development)
- 6| A⁹st⁹tckv Db⁹w⁹Z⁹w⁹f⁹u⁹E⁹K Kgx⁹Dbq⁹ (Internal career ladder staff development)
- 7| ew⁹:tckv Db⁹w⁹Z⁹w⁹f⁹u⁹E⁹K Kgx⁹Dbq⁹ (External career ladder staff development)
- 8| `w⁹t`⁹ukZ Kgx⁹Dbq⁹ (Self directed staff development)

w⁹t⁹P Kgx⁹Dbq⁹bi G g⁹wj ,tjv m⁹st⁹q⁹tc Avtj w⁹PZ nj :

1| ukLb-tkLvtbv Kv⁹h⁹f⁹u⁹E⁹K Kgx⁹Dbq⁹: G c⁹x⁹w⁹Z⁹tZ uk⁹qK w⁹t⁹R c⁹u⁹tg w⁹ef⁹b⁹atK⁹sktj (w⁹f⁹w⁹l tUc, mnKgx⁹ i gj`vq⁹b BZ`w⁹) w⁹t⁹Ri uk⁹q⁹v⁹vb Kv⁹th⁹P gj`vq⁹b Ki⁹teb| gj`vq⁹tb c⁹u⁹ dj vdtj i w⁹f⁹u⁹E⁹tZ Z⁹u⁹ uk⁹q⁹v⁹vb Kv⁹th⁹P gv⁹t⁹b⁹vq⁹tb w⁹ef⁹b⁹atZ⁹E; I tK⁹skj Ab⁹yiY Ki⁹teb| AZ:ci th Z⁹E; I tK⁹sktj i Dc⁹th⁹w⁹MZv c⁹g⁹w⁹YZ nq t⁹m⁹U M⁹h⁹Y ce⁹R evKx ,tjv eR⁹ Ki⁹teb| Gf⁹te uk⁹qK e`w³MZf⁹te tckvMZ `qZvi gv⁹t⁹b⁹vq⁹tb Ki⁹tZ cvi⁹teb|

2| m⁹h⁹w`⁹ c⁹uk⁹qY⁹u⁹f⁹u⁹E⁹K Kgx⁹Dbq⁹: G c⁹u⁹qv⁹tZ Kgx⁹Dbq⁹bi MZvb⁹M⁹u⁹ZK c⁹uk⁹q⁹t⁹Yi c⁹w⁹etZ⁹m⁹h⁹w`⁹ c⁹uk⁹q⁹t⁹Yi Dci ,ia⁹z; t`l qv nq| MZvb⁹M⁹u⁹ZK c⁹uk⁹q⁹Y c⁹x⁹w⁹ c⁹vb⁹Z c⁹x⁹w⁹Z⁹w⁹f⁹u⁹E⁹K Ges GtZ uk⁹Qyce⁹c⁹w⁹i K⁹w⁹Z Av⁹PiY (programmed behaviour) tkLvi Dci t⁹Rvi t`l qv nq| Ab⁹w⁹ tK focused training c⁹u⁹qv⁹ uk⁹q⁹v⁹t⁹q⁹t⁹ w⁹ef⁹b⁹atM⁹tel Yvi g⁹v⁹tg D⁹w⁹ieZ dj c⁹h⁹-uk⁹q⁹v⁹vb c⁹u⁹qv⁹w⁹f⁹u⁹E⁹K c⁹uk⁹q⁹t⁹Yi Dci t⁹Rvi t`l qv nq| G c⁹u⁹qv⁹ uk⁹qK w⁹t⁹R G c⁹x⁹w⁹ ,tjv tk⁹YxK⁹t⁹q e`envi Kti Z⁹u⁹ uk⁹q⁹v⁹vb c⁹x⁹w⁹Zi gv⁹t⁹b⁹vq⁹tb Ki⁹tZ cvi⁹teb|

3) ለመሥሪያቤት ግዢ ጥራት ማረጋገጥ: ግዢ ጥራት ማረጋገጥ ማለት ማለፍ ያለውን አገልግሎት ለሌሎች ማስገኘት ነው። ለዚህ ግብ ለማሳካት ማረጋገጫው የሚሆነው የጥራት ማረጋገጫው በሌሎች ለማስገኘት ማስተካከል ነው። ለዚህ ግብ ለማሳካት ማረጋገጫው የሚሆነው የጥራት ማረጋገጫው በሌሎች ለማስገኘት ማስተካከል ነው።

4) የሰው ሀብት ግዢ ጥራት ማረጋገጥ: ሰው ሀብት ግዢ ጥራት ማረጋገጥ ማለት ሰው ሀብት ማረጋገጫ ነው። ለዚህ ግብ ለማሳካት ማረጋገጫው የሚሆነው የጥራት ማረጋገጫው በሌሎች ለማስገኘት ማስተካከል ነው። ለዚህ ግብ ለማሳካት ማረጋገጫው የሚሆነው የጥራት ማረጋገጫው በሌሎች ለማስገኘት ማስተካከል ነው።

5) የጥራት ማረጋገጫ ስልጠና ለማሰጠት ግዢ ጥራት ማረጋገጥ: የጥራት ማረጋገጫ ስልጠና ለማሰጠት ማረጋገጫ ማለት የጥራት ማረጋገጫ ስልጠና ማሰጠት ነው። ለዚህ ግብ ለማሳካት ማረጋገጫው የሚሆነው የጥራት ማረጋገጫው በሌሎች ለማስገኘት ማስተካከል ነው። ለዚህ ግብ ለማሳካት ማረጋገጫው የሚሆነው የጥራት ማረጋገጫው በሌሎች ለማስገኘት ማስተካከል ነው።

6) ለድርጊት ስራ ማረጋገጫ ስልጠና ለማሰጠት ግዢ ጥራት ማረጋገጥ: ለድርጊት ስራ ማረጋገጫ ስልጠና ለማሰጠት ማረጋገጫ ማለት ለድርጊት ስራ ማረጋገጫ ስልጠና ማሰጠት ነው። ለዚህ ግብ ለማሳካት ማረጋገጫው የሚሆነው የጥራት ማረጋገጫው በሌሎች ለማስገኘት ማስተካከል ነው። ለዚህ ግብ ለማሳካት ማረጋገጫው የሚሆነው የጥራት ማረጋገጫው በሌሎች ለማስገኘት ማስተካከል ነው።

7) ለስልጠና ስልጠና ስልጠና ለማሰጠት ግዢ ጥራት ማረጋገጥ: ለስልጠና ስልጠና ለማሰጠት ማረጋገጫ ማለት ለስልጠና ስልጠና ማሰጠት ነው። ለዚህ ግብ ለማሳካት ማረጋገጫው የሚሆነው የጥራት ማረጋገጫው በሌሎች ለማስገኘት ማስተካከል ነው። ለዚህ ግብ ለማሳካት ማረጋገጫው የሚሆነው የጥራት ማረጋገጫው በሌሎች ለማስገኘት ማስተካከል ነው።

cW 4.5

KgrDbqb Kvhpig gj`vqb Ges , YMZ mPK

[Evaluation of Staff Development Programme and Quality Indicators]

Dt`ik`

GB cW tk`l Av`cib -

- KgrDbqb Kvhpig gj`vqtb , ia`ze`vL`v KitZ cvi`teb ;
- KgrDbqb Kvhpig gj`vqtb we`te`PZ w` K , tj`v Dt`j`L KitZ cvi`teb;
- KgrDbqb Kvhpig gj`vqb c`l`u`qvi av`c , tj`v we`Z KitZ cvi`teb Ges
- KgrDbqb Kgrm`P gj`vqtb , YMZ mPK Dt`j`L KitZ cvi`teb|

**KgrDbqb Kvhpig
gj`vqtb , ia`z;**

gj`vqb KgrDbqb c`l`u`qvi Ab`Zg , ia`z`c`y`-li | Gi gva`tg R`v`v h`v`q KgrDbqb Kgrm`P uba`m`i Z j`q`l` I Dt`ik` AR`b KZU`v m`n`v`q`K n`t`q`Q | G`O`v`o`v KgrDbqb Kgrm`P gj`vqtb c`l`B Z`-w` f`i`e`l`Z KgrDbqb Kgrm`P`K A`w`a`K`Z`i K`v`h`R`i`x K`i`v`i D`c`v`q m`a`u`t`K`-t`h`S`v`K m`x`v`S`l` M`b`t`Y m`n`v`q`K n`t`Z c`v`i` | w`k`q`v`v c`l`Z`o`v`t`b`i t`q`q`t`I KgrDbqb gj`vqb c`l`u`qvi w`k`L`b`-t`k`L`v`t`b`v`i g`v`b e`w`x`i g`v`a`t`g c`l`Z`o`v`t`K m`d`j`Z`v`i w`t`K G`w`M`t`q w`b`t`Z c`v`i` | A`Z`G`e` c`l`Z`o`v`b K`Z`R` M`n`x`Z KgrDbqb c`l`u`qvi h`-v`h`-f`v`t`e` gj`vqb KitZ n`te|

KgrDbqb Kgrm`P gj`vqtb we`te`PZ w` Kmg`n`

KgrDbqb Kgrm`P`Z gj`vqb c`l`u`qvi Dt`ik` , c`x`w`Z , gj`- we`P`v`t`i`i g`v`b`-E` B`Z`-w` m`y`u`o`f`v`t`e` we`Z`-v`K`t`Z` n`te| G , tj`v c`l`v`q`tb gj`vqb m`a`u`m`K`Z t`b`t`f`v` (Nevo, 1976) -i t`l`q`v 10`w`U` w`K` t`h`S`v`K`f`v`t`e` we`te`P`Z` n`t`Z` c`v`i` | G , tj`v` n`j` -

**gj`vqtb we`te`PZ
w` Kmg`n`**

- gj`vqtb ms`A`v` e`v` a`v`i` Y`v`
- gj`vqtb K`v`R`
- gj`vqtb w`e`l`q`
- gj`vqtb K`x` a`i`t`b`i` Z`-` m`S`M`n`x`Z` n`te`
- gj`vqtb Dt`ik` AR`b`i` g`v`I`v` w`b`i`f`c`t`Y`i` g`v`b`-U` (criteria)
- K`v`t`K` gj`vqb K`i`v` n`te`
- gj`vqb c`l`u`qvi
- gj`vqtb e`-e`u`Z` A`b`m`U`v`b` c`x`w`Z`
- t`K` gj`vqb K`i`t`e`b`
- gj`vqb d`j`v`d`j` we`te`P`b`v`i` g`v`b`-U`

gj`vqb m`a`u`m`K`Z` G` m`K`j` c`l`k`i`e` D`E`i` KgrDbqb Kvhpig`K` A`f`x`o` j`q`l` AR`b` I` , YMZ`g`v`b` w`b`w`O`Z` K`i`t`Z` m`n`v`q`K` n`te`|

gub`U GK : Kgr`Dbqbi Kwitgv

th tKiv Kgr`Dbqbi Kgr`Pi GKiu ubw`0 Kvitgvi wfiE`Z cwi Pvi Z nte, hvi D`ik` nte c`Ziu e`i`3i c`e`x ev Dbqbi | G D`ik` Ggb GK mnvqK cwi tek m`o Ki`Z nte thLvtb e`i`3i c`j`v`c`j` RuoZ nI qvi m`j`h`M c`te Ges G e`v`c`i`ti c`j`v`c`j` c`k`v`m`b`K mnvqZv c`v`l`q`v` h`v`te | G gub`U Avl Zvq th w`K` t`j`v` vetePbv Ki`Z nte Zv ntj`v` –

**Kgr`Dbqbi Kwitgvi
YMZ mPK**

- 1.1 Kgr`Dbqbi Kgr`Pi Avl`c`n`l`q`v`i` c`teB Gi m`e`te` m`g`j` m`e`u`i`K`AskM`h`Y`K`v`i`x`i` AewZ Ki`Z nte |
- 1.2 mnvqK DcKiY hv t`_`i`K AskM`h`Y`K`v`i`x`i`v DcKZ.n`te Zv c`teB mieivn Ki`Z nte |
- 1.3 Kgr`Pi mgqZv`j` Kv m`e`u`i`K`c`e`f`_`i`KB mKj`_`i`K AewZ Ki`Z nte |
- 1.4 Aa`_`j` ev c`h`v`b` w`k`_`j`K, Ab`v`b` c`k`v`m`K Ges AskM`h`Y`K`v`i`x`i`i Kgr`Dbqbi Kvh`p`i`tg`i` c`i`Z` mnvqZvi g`t`b`v`f`v`e` `Zvi Ki`Z nte |
- 1.5 Kgr`P`i`Z AskM`h`Y`i` m`j`e`av` c`i`Z`o`v`t`b`i` m`m`i` `i` KivQ m`m`K`f`v`te` Z`j` ai`Z` nte |
- 1.6 Kgr`Dbqbi Kgr`P`i`Z AskM`h`Y`K`v`i`x`i`i` w`k`_`j`v` c`i`Z`o`v`b` KZ`R` c`j`v`Z`Kivi e`e`v`_`v`K`te |
- 1.7 G`i`Z` AskM`h`Y`i` Rb` `Kvi`l` Dci` t`Rvi` c`o`q`m` Kiv h`v`te` b`v` |
- 1.8 me` `j``t`q`i` `b`q`u`g`Z` Kiv`h`P` e`t`m`i` evB`ti` Kgr`Dbqbi Kiv`h`p`i`tg` AskM`h`Y`i` Rb` `w`K`Q`y` D`i`x`c`b`v`i` (incentives) e`e`v`v` me` `j``t`q` ev` w`k`_`j`v` c`i`Z`o`v`t`b`_`v`K`i`Z` nte |

gub`U`B: Pwn`v`ibijcY`b`w`Z` Ges`c`i`u`q`v`

Kgr`Dbqbi Kgr`Pi Pwn`v`ibijcY`i` Rb` `m`j`b`w` `0` b`w`Z` Ges`c`i`u`q`v` Aej` `b` Ki`Z` nte | G D`ik` `w`etePZ` w`K` t`j`v` nj` –

**Pwn`v`ibijcY`
weteP`velq**

- 2.1 c`o`q`v`R`b`q`Z`v`i` Dci` wfiE` K`i` Pwn`v`ibijcY` Ki`Z` nte |
- 2.2 Kgr`Dbqbi cwi K`i`bv Ges`c`i`u`q`v` t`j`v` h`_`v`h`_`f`v`te` w`e`Z` ev` D`j`L` Ki`Z` nte |
- 2.3 c`i`Z`o`v`b` c`h`v`b` Ges` Kgr`Dbqbi` w`e`t`k`l`A`e`v` Pwn`v`ibijcY` c`j`v` `m` Ges` Kgr`Dbqbi` c`i`u`q`v`i` m`v`_`_`f`v`t`j`v`f`v`te` c`w`i`PZ` Ges` Zv` e`e`n`v`t`i` `j` `n`teb |
- 2.4 c`i`Z`iu` Kgr`Dbqbi Kgr`Pi Ges` c`e`Z`x`w`Z`b` e`Q`i` m`S`N`u`Z` Ab`j`c` Kgr`Pi` c`o`q`v`R`b`q` t`i`K`W`c`i`Z`o`v`t`b` m`S`i`w`j`Z`_`v`K`i`Z` nte |
- 2.5 ÷`v`d` m`m`i` `i` c`o`Z` `i`K`i` t`c`k`v`M`Z` Dbqbi` cwi` K`i`bv` b`v`_`i`Z` A`S`f` ` Ki`Z` nte |

gub`U`w`Z`b` : Dc`f` `o`v` K`u`g`u`l`

w`k`_`j`v` c`i`Z`o`v`t`b` Kgr`Dbqbi` m`S`m`v`S`i` GKiu` Dc`f` `o`v` K`u`g`u`l`_`v`K`te | Gi` `v`i`q`Z`i` nte Kgr`Dbqbi` c`i`u`q`v`i` m`v`_`_`m`S`i`k`o` m`K`j`i` AskM`h`Y`K` Ab`z`o`w`Z` Kiv |

- 6.3 KgrmP Ggbfite Kivtve× KitZ nte thb AskMhYKvixe,` mnKgrP i Avb I AwfAZv t`tK DckZ.nl qvi mthvM cvq|
- 6.4 tKvtpP mgomxgv cZ`vkZ j`q` I thvM`Zv AR#bi Rb` ch#B nte|
- 6.5 tKvtpP Df`k` we`ij tqi mmeR Df`k` Ges `vbxq ukqVv wefivM ev Awdm KZR AvtqmRZ KgrDbqb KgrmPi mv_ m½wZcYqntZ nte|
- 6.6 uba#i Z j`q` I thvM`Zvmgr- AR#b KgrDbqb tKvm@cFve ivLtz cvi tQ ukbv Zv cwi gvtci e`e`v`vKtZ nte|
- 6.7 ce` uba#i Z Pwn`v wbfcy cZte`tbi wfiEtZ Kgr` Dbqb KgrmP AskMhYKvix`i mjbw` 0 tckvMZ Dbq#bi j`q` cwi Pwj Z nte|
- 6.8 AskMhYKvix`i tiwS Gi gva`tg t`Ltz nte KgrDbqb KgrvU Zvt`i Kgrm`uv`b Ges tckvMZ Dbq#bi Pwn`vi cwi c`K ukbv ?

gub`U mvZ : KgrDbqb c`k`q`K

KgrDbqb c`k`q`Ke,` D`P thvM`Zvm`ubenteb| Zviv Ggb `q`Zv I AwfAZvi Awakvix nteb hvZ AskMhYKvixe,` cY`Av`v AvbtZ cvi Ges mePZK AskMhY wbuDZ nq|

**KgrDbqb c`k`q`tYi
thvM`Zv**

- 7.1 tKvtpP melqe`i Dci c`k`q`Ke,`i wekI `q`Zv`vKtZ nte|
- 7.2 c`k`q`KMtYi `kZ.wekIÁ ch#qi `q`Zv`vKtZ nte hv Zui Kg@cPÓvq wek/mthvM`Zv Avbte|
- 7.3 KgrDbqb c`k`q`tKi AskMhYKvix`i mv_ NwbZv`vctbi mvq`_vKte| tmB mv_ AskMhYKvix`i mgm`v Ges Pwn`v Dcj wäi `q`ZvI Zvi`vKtZ nte|
- 7.4 c`k`q`Kt`i eq`_ukLb ZEj m`ú`K`m`y`ú`o avi Yv`vKtZ nte|
- 7.5 c`k`q`tKi ukLb-tkLvtrv Kvhrvj tZ (instructional strategies) dj veZ0 Ges mnvqZv c0vbgj-K KgrvU AšfZ `vKtZ nte|
- 7.6 c`k`q`tKi dj c`h-KgrmP ev`evq#bi `q`Zv`vKtZ nte|

gub`U Aw : tKvm`ev Kvhrtgi Df`k` cwi c`Y (Meeting course or Activity objectives)

KgrDbqb tKvm`Ges Kvhrtgi Df`k` KZUv AwRZ ntqtQ Zv uba#Y Kivi `q`Zv we`ij tqi ev msuk0 cZ0v#bi ev KZP`t`qi`vKtZ nte|

**KgrDbqb Kvhrtgi
gj`vq#bi weP`
velq**

- 8.1 cZ0v#b KgrDbqb tKvm`gj`vq#bi wj wLZ bwxZgij v Ges c0Lqv`vKtZ nte|
- 8.2 KgrDbqb tKvtpP AwRZ Avb Kvhrtgi KZUv Kvhriv#te c0qvm nt`Q tmUv h_vh_ Abywi K (Follow-up) KvRi gva`tg cwi exqY (monitor) KitZ nte|
- 8.3 mKj KgrDbqb tKvtpP Kvhrvvi Zv AskMhYKvix`i 0viv tiwS KivZ nte|

gub`U bq : AbyviK Kvr Ges tRvi`viKiY (Follow-up and Reinforcement)

**KgxDbqb KgmP
cimeY**

9.1 cĳkYi gra`tg AWRZ Ávb, `YZv I `wofwzi tRvi`viKiY Ges tUKmBKItYi Rb` KZĳY KgxDbqb KvhĳgtK wbgwZ Abyvi Y Kiĳeb|

9.2 AWRZ `YZv Ges Ávb Kvhĳgtĳ KZUv cĳqM Kiv nt`Q Zv avivemK Abyvi K KvtRi gra`tg wPyZ KiĳZ nte|

gub`U`k : AskMhYKvixet`i Ae`vb (Participants' Contribution)

wkYv cĳZvĳbi KgxDbqb KgmPtZ AskMhYKvixet`i aviYv Ašfĳ Kivi mĳhM_vKte|

**KgxDbqb djvdĳi
ev`e cĳqM**

10.1 KgxDbqb tKvtmAskMhY KĳiĳQb Ggb e`w³eMĳK we`ijĳi ev wkYv cĳZvĳbi Abjĳc KgmP gj`vqb Ges cwiĳvRĳb fĳgKv ivLvi mĳhM wĳZ nte|

10.2 AskMhYKvixet`i msĳkUó cĳZvĳbi wR`^ KgxDbqb tKvmAvĳvRb, ev`evqb, cwiexY Ges mĳkvaĳb KZUv Ae`vb ivLĳZ tĳiĳQb Zv cĳZvĳqZ tiwS -Gi e`v_vKĳZ nte|



cĳVvĳi gj`vqb 4.5

A) msĳĳB Dĳi cĳæ

1. KgxDbqb Kvhĳg gj`vqĳbi , iazjeYĳv Kiĳb|
2. tĳĳvi ĳZ tKvb w K,ĳjv KgxDbqb Kvhĳgti , YMZgvb ewx KiĳZ cĳti ?
3. KgxDbqb Kvhĳgti tKvb w lq,ĳjv gj`vqb Kiv DĳPZ ?
4. KgxDbqb Kvhĳg gj`vqĳbi gub`U wbaĳĳY weteĳPZ w lq,ĳjv Kx ?
5. KgxDbqb KgmPi Kvtgv gj`vqĳbi gub`U,ĳjv Kx ?
6. KgxDbqĳbi wkLb-tkLĳtv cĳqM Kx gub`Uĳi wĳĳĳZ weteĳPZ nI qv cĳqRb ?

Av) iPbvĳj-K cĳæ

1. KgxDbqb KgmP gj`vqĳb weteĳPZ w K,ĳjv Kx? KgxDbqb gj`vqb cĳqM avc,ĳjv Avĳj vPbv Kiĳb|
2. KgxDbqb KgmP gj`vqĳbi , YMZ mPK,ĳjv eYĳv Kiĳb|
3. KgxDbqb KgmP wkYvi , YMZgvbĳK wkfĳte cĳwĳZ Kĳi - e`vL`v Kiĳb|



Povšigj`iqb 4

A) msrŋB DĒi cĕæ

1. KgrDbq̄b Ges KgrcĕkŋŋiYi cv_R` Kx?
2. KgrDbq̄b AtbK teik fivel`Zgŷx tKb?
3. KgrDbq̄b cĕŋqvi AZxZ I eZŋvb cwi mi Avtj vPbv Kiab|
4. KgrDbq̄b cĕŋqvi cĕZōvtbi Dbq̄tb ŋKfite mivh` Kti?
5. KgrDbq̄b KgrŋP tKb ŋKŋv cĕZōvtbi Dbq̄b KgrŋPi Avef`Q` Ask nI qv cĕŋqRb?
6. KgrDbq̄tbi cĕvb chŋqŋU mstŋŋc Avtj vPbv Kiab|
7. KgrDbq̄b Kvhŋig gj`vqtb weŋŋPZ ŋ`K, tj v Kx?
8. KgrDbq̄tbi mbvZb tKškj , tj v Kx?
9. chŋŋŋY I weŋkŋY cŋŋZ ŋKfite ŋKŋŋKi tckvMZ Dbq̄tb mivqK ntZ cvti ?
10. Avgvŋ`i t`tk ŋKŋKt`i tckvMZ Dbq̄tb thš_ we`ij q Dŋ`vŋMi cĕŋqMthvM`Zv mŋŋŋK`Avcbvi AvfŋZ ŋj Lŋ|
11. e`ŋ³ chŋq ŋKŋKt`i tckvMZ Dbq̄tbi cŋŋZ, tj v Kx ?
12. ŋKŋŋKi tckvMZ Dbq̄tb tgav gj`ŋŋŋŋK KgrDbq̄b gŋWtj i , iæzj chŋŋj vPbv Kiab|
13. tbtŋvi gŋZ tKvb ŋ`K, tj v KgrDbq̄b Kvhŋŋgi , YMZgvb eŋŋ KiŋZ cvti ?
14. KgrDbq̄b cĕkŋŋKi Kx , Yveŋj _vKv cĕŋqRb ?

Av) iPbvŋj-K cĕæ

1. KgrDbq̄b KvŋK etj ? ŋKŋv cĕZōvtb KgrDbq̄tbi , iæzje`vL`v Kiab|
2. KgrDbq̄b bŋŋZi Dŋŋk` weZ Kiab| cŋŋj Z KgrDbq̄b cĕŋqvi mŋgve`Zv, tj v Avtj vPbv Kiab|
3. KgrDbq̄b KvhŋŋŋK mdj KiŋZ ntj tKvb tKvb ŋ`ŋK bRi t`I qv cĕŋqRb - e`vL`v Kiab|
4. ŋKŋv cĕZōvtbi Af`šŋŋY`kŋU cĕvb KgrDbq̄b tKškj eYŋv Kiab|
5. e`ŋ³ chŋq KgrDbq̄tbi gŋWj , tj v Kx? mstŋŋc G, tj v Avtj vPbv Kiab|
6. KgrDbq̄b gj`vqtb weŋŋPZ ŋ`K Ges avcmŋŋ Avtj vPbv Kiab|

cW 5.1

gj`vq`bi A_ , ia`j;I , YMZgvb ibv`DZKi`Yi c`qurBvqZv
[Meaning, Importance and Need for Quality Assurance]

D`i`k`

GB cW tk`l Av`cub -

- gj`vq`bi avi Yv weez Ki`Z cvi`teb ;
- ik`q`v gj`vqb Kx Zv ej`tZ cvi`teb;
- KuZZj;gj`vq`bi avi Yv weez Ki`Z cvi`teb;
- gj`vqb msik`w cvi` fvm`l K k`a` , tj`v ms`Av`vqZ Ki`Z cvi`teb;
- ik`q`v gj`vqb I cvi` gv`t`ci m`x`u`K`P`v`y`Z Ki`Z cvi`teb;
- ik`q`vq gj`vq`bi , ia`j;e`v`L`v Ki`Z cvi`teb Ges
- gj`vqb c`q`u`q`v , YMZgvb ibq`š`f`Yi c`q`u`r`B`v`q`Z`v D`j`L` Ki`Z cvi`teb |

gj`vqb Kx?

gj`vq`bi avi Yv

gj`vqb k`a`u` Av`v`b`K ik`q`v`v`q`i` Av`Z c`q`u`v` Z GK`u` k`a` | Av`v`f`v`v`b`K A`_`gj`v`qb nj `O`The process of ascertaining or judging the value or amount of something by careful appraisal. A`_` m`p`Z`b` v`e`P`v`i` v`e`f`k`d`i`Yi` g`v`a`'`g` t`K`v`b` i`K`O`j` D`c`i` gj`v` Av`i`v`c` ev` cvi` gv`Y` h`v`P`v`B`t`q`i` c`q`u`q`v`B` nj` gj`v`qb | Av`i`l` m`n`R`f`v`t`e` ej`v` h`v`q` , t`K`v`b` v`e`l`t`q`i` D`i`k` ik`q`v`_`x`P`v` K`Z`U`K`z`A`v`q`Z`j` Ki`Z` t`c`i`t`q` Z`v` i`b`i`f`c`i`Yi` R`b` i`b`i`e`w`Q`b`e`v`t`e` Z`_` m`S`M`h` , v`e`P`v`i` v`e`f`k`d`Y` I` c`u`B` d`j`v`d`t`j` i` v`f`v`E`t`Z` i`m`x`v`š`l` M`h`i`Yi` c`q`u`q`v`B` nj` gj`v`qb |

ik`q`v` gj`vq`bi avi Yv

ik`q`v` GK`u` D`i`k``g`v`x` c`q`u`q`v` h`v`i` c`a`v`b` j` q`i` nj` ik`q`v`_`x`P` m`v`v`e`R` v`e`K`v`k`m`v`ab` | G`j` q`i` AR`f`b`i` D`i`k` ik`q`v`_`x`P` v`e`w`f`b`e`v`i`t`b`i` v`e`w`b`t`q`v`M` (t`f`S`Z` m`y`e`v` , i`k`L`b` m`i`g`M`h` , i`k`q`v`K` , m`g`q` B`Z`_`v`)` K`i`v` n`q` | GB` v`e`w`f`b`e`v`i`t`q`v`M`i` g`v`a`'`g` ik`q`v`_`x`P` ik`q`v`i` D`i`k` AR`f`b` K`Z`U`v` m`q`i`g` n`t`q`f`Q` A`_` ik`q`v`_`x`P` Av`P`i`t`Y` K`Z`U`v` e`v`v`A`Z` c`v`i`e`Z`B` m`v`v`a`Z` n`t`q`f`Q` Z`v` h`v`P`v`B` K`i`v`i` t`h` i`b`i`e`w`Q`b`e`v`i`t`q`v` t`m`U`v`B` nj` ik`q`v` gj`v`qb | AZ`G`e` ik`q`v` gj`v`qb` GK`u` av`i`v`e`w`v`n`K` I` v`e`v`a`e`x` e`e`v` h`v`i` m`v`v`v`t`h` ik`q`v`i` m`i`g`v`M`K` D`i`k` AR`f`b` ik`q`v`_`x`P` K`Z`U`v` m`d`j` n`t`q`f`Q` Z`v` i`b`i`f`i`c`Z` n`q` |

KuZZj;gj`vq`bi avi Yv

ik`q`v`i` GK`u` Ab`Z`g` c`a`v`b` j` q`i` nj` ik`q`v`_`x`P` Av`b` , `q`i`Z`v` , `v`f`v`w`z` I` gj`v`t`e`v`t`a`i` c`v`i`e`Z`B`i` g`v`a`'`g` Z`v`i` Av`P`i`t`Y`i` e`v`v`A`Z` c`v`i`e`Z`B` Av`b`q`b` | G` D`i`k` ik`q`v`_`x`P` g`v`a`'`g` GK` , `Q` j` q`i` , D`i`k` I` v`e`l`q`e`v` i`b`a`f`i`Y` K`i` Gi` g`v`a`'`g` ik`q`v`_`x`P` Av`P`i`t`Y`i` e`v`v`A`Z` c`v`i`e`Z`B` Av`b`q`b`i` j` q`i` v`e`w`f`b`e`v`i`t`b`i` i`k`L`b`-` t`k`L`v`t`b`v` K`v`h`v`e`v`j` i` Av`t`q`v`R`b` K`i`v` n`q` | d`j` k`a`z`t`Z` ik`q`v`_`x`P`v` t`K`v`b` i`b`a`f`i` Z` ik`q`v`Y`x`q` v`e`l`t`q` t`h` Av`b` , `q`i`Z`v` , `v`f`v`w`z` I` gj`v`t`e`v`a` AR`f`b` K`i` t`m`U`v`B` nj` ik`q`v`_`x`P` KuZZj` (achievement) | Av`i` v`e`w`f`b`e`v`i`t`q` ik`q`v`_`x`P` KuZZj` h`v`P`v`B`t`q`i` c`x`v`Z` ev` c`q`u`q`v` nj` KuZZj` gj`v`qb |

**gj`vqb mweR` iKŠ`
cwi gvc wev`Obægr`**

2. gj`vqb mweR` , Ym`úbæ iKŠ` cwi gvc wev`Obægr` gj`vqb iKŷv_xP` ``wnK, gvbimK, mvgwiRK, tešx`K BZ`w` wevfbæ`enkto`i cwi gvc Kti | Avi cwi gvc GK GKiu`enkó` ev` nel tqi AR` ev` iK Lb AM`wZ cwi gvc Kti |

**gj`vqb` YMZ` I
cwi gvYZ iKŠ` cwi gvc
tKej cwi gvYZ**

3. gj`vqtb iKŷv_xP` tKvb`enkto`i cwi gvYZ I` , YMZ Df q` w` K wePvi Kiv nq | Ab`w` tK cwi gvc nj` tKvb`enkto`i cwi gvYZ wePvi | thgb- GKRB iKŷv_xP` Kiv`úDUvi iKŷv` nel tq 60% b` tctqtQ | GUv Zvi Kiv`úDUvi iKŷv` nel tqi Ávtbi cwi gvc | Avi Gi` w`ÉtZ Ges Ab`vb` assessment cŷuqv` mivvth` hiv` ej` v` nq BwZnim` nel tq Zvi` KwZ; mštl` RbK Zte` tmUv` gj`vqb |

**gj`vqb avivewnK
cŷuqv, iKŠ` cwi gvc
wev`Obæcŷuqv**

4. gj`vqb GKiu` avivewnK cŷuqv | Ab`w` tK cwi gvc m`úYp`c mvguqK e`e`v | GKiu` w`v` mgq Ašl` tKvb` nel tq iKŷv_xP` KZUKz`iK Lb AM`wZ n`qtQ` tmUvB nj` cwi gvtci D`i`k` | Ab`w` tK gj`vqb tKvb` mvguqK cŷuqv bq; eis` GiU` GKiu` Avew`Obæcŷuqv |

5. gj`vqtb`i` tŷt` gj`gvb (value judgment) Av`ivc Kiv nq, iKŠ` cwi gvc`i` agv`i` be`K |

ikŷvi` , YMZgvb` w`v`DZKi`Y` KwZ; gj`vqtb`i` , ia`z`i`

**KwZ; gj`vqtb`i`
 , ia`z`i`**

ikŷv_xP` KwZ; gj`vqb` iKŷvi` Awet`Q` Ask | iKŷK, iKŷv_xP` Awf`fveK` mKtj`i` Rb`B` GiU` , ia`z`c`Y` KwZ; gj`vqtb`i` gva`tg` iKŷK` I` Awf`fveKMY` RvbtZ` cvtib` GKRB` iKŷv_xP` tKvb` nel tq` KZUKz`Ávb` ev` `ŷZv` AR` Kti`Q | G` aitbi` gj`vqb` iKŷv_xP` Ávb` AR` I` cv`w`elq` AvqE`; Kitz` t`Yv` t`q | Gi` w`ÉtZ` iKŷK` I` cŷuvmKgE`j`x` Dch` Kge`w`i`K`i`bv` I` Kvh`p`g` Zwi`tZ` mg`nb | G`ovon` iKŷvi` , YMZgvb` w`v`DZKi`Y` KwZ; gj`vqtb`i` weK`i` tbB | Kvi`Y` gj`vqtb`i` gva`tg` iKŷK` Zui` iKŷv` vb` Kvt`Ri` Kvh`R`w`i` Zv` wePvi` I` Dch` iK Lb` tkLv`tbv` c`x`wZ` w`be`Pb` Kitz` cvtib | Gi` gva`tgB` wevfbæ` nel tq` iKŷv_xP` iK Lb` AM`wZ` Z`v` KwZ; Ziv`ch`e`Y`v`te` wePvi` Kiv` m`æ` nq | nel qe` ; iK Lb` tkLv`tbv` c`x`wZ` I` e`e`üZ` iK Lb`-tkLv`tbv` tKŠkj` , t`jvi` Kvh`R`w`i` Zv` iKŷv_xP` KwZ; gj`vqtb`i` gva`tg` wePvi` Kiv` m`æ` nq | gj`vqb` th`tnZz`GKiu` Avew`Obæcŷuqv, Gi` gva`tg` iKŷv_xP` avivewnK` AM`wZ` m`ú`K` Rv`bv` hvq | Gfiv`te` iKŷv_xP` iK Lb` m`ú`wK` m`y`av` Am`y`av` , t`jv` AeinZ` n`tq` cŷuqv`R`b`x` w`biv`ggj`-K` e`e`v` M`h`Y` Kiv` m`æ` nq | gj`vqb` iKŷv`m`tgi` Kvh`R`w`i` Zv` m`ú`K`P` AeinZ` Kti` Ges` cwi` gvR` I` gvt`bv`qtb`i` w` K` w`b` `R`bv` t`q | Gfiv`te` gj`vqb` iK Lb`-tkLv`tbv` Kvh`p`tgi` cŷZui` `t`i` , YMZgvb` w`bqš`ŷ`Yi` gva`tg` iKŷvi` dj` cŷh`-I` D`i`k``g`lx` ev` `é`vqtb` miv`qZv` Kti |

gj`vqb` cŷuqv` , YMZgvb` w`bqš`ŷ`Yi` cŷuqv`R`b`x`Zv`

Dcti`i` Av`tj`v`Pbv` t`_tK` Av`giv` Rvbj`vg` iKŷv_xP` KwZ; gj`vqb` tKb` , ia`z`c`Y` iKŠ` GZ` , ia`z`c`Y`n`I` qv` m`É`j`l` gj`vqb` cŷuqv`w` hiv` , YMZgvb`m`ú`b`æ`v` nq` Zv` n`tj` gj`vqb` D`i`k`` AR` e` `n`te | Avi` Gi` cŷiv`e` cote` mgM`w`iKŷv` e`e`v`i` Dci | dtj` iKŷvi` cŷ`w`kZ` D`i`k`` AR` e`v`nZ` nte |

Avgv`i t`tk ukġvi newfbæ`ti i ,YMZgvb ubtq eZgvtb th mskq
t`Lv w`tqtQ Zvi GKwU Ab`Zg KviY`ġ gj`vqb cġqv|

gj`vqb Kvhġg newfbæ Dcvtq Ges bibwea DcKiY I cwi gvc c`xZi mnv`th`
cwi Pwvj Z nq| G,tj vi h_vh_ wbePb, cġqb I ev`bvqtb Dci wbfP Kti gj`vqtb i
,YMZgvb| Avi ZvB ukġK I ukġv msukw Ab`vb`ti i gj`vqb I Gi newfbæ tKŠkj
Ges nmZqvi m`utK`h_vh_ avi Yv_vKv cġqvRb| cieZx`civ, tj vtZ ukġv_xP KwZZ;
gj`vqtb i newfbæ, iæZc`Y`K Ges ,YMZgvb ubqš`Yi Dcvq m`utK`Avtj vKcvZ Kiv
ntqtQ hv GKwU ,YMZgvb m`ubæ gj`vqb cġqv i `ewkó` Rvb`Z I ev`bvqtb DØx I
mnvqZv Ki te|



cv`Vv`Ei gj`vqb 5.1

A) msuġB D`Ei cġæ

1. gj`vqb ej tZ Kx ešvq ?
2. ukġv gj`vqb Kx ?
3. KwZZ; gj`vqb Kv`K etj ?
4. ukġv_xP KwZZ; gj`vqtb i ,iæZ; e`vL`v Ki ab|
5. gj`vqb cġqv i ,YMZgvb ubqš`Y Kivi cġqvRbxqZv Kx ?

Av) iPbvġj-K cġæ

1. gj`vqb msukw cwi fvl K kã ,tj v D`vni Ymn eY`v Ki ab|
2. (K) ukġvMZ gj`vqb I cwi gvtci cv`R` ubifcy Ki ab|
(L) wbtPi tKvbU gj`vqb Ges tKvbU cwi gvtK wbt`R Kti - hv`mnKv`ti e`vL`v
Ki ab|
 1. ewl R ci xġvq gvnd`v wAvtb 75 b`f tctqtQ|
 2. wAvb wel`tq gvnd`vi KwZZ; m`š`i RbK|

cW 5.2

gj`vqtbj KvR, cKvitf` , avc I bwiZgvj v

[Functions, Types, Steps and Principles of Evaluation]

Df`ik`

GB cW tk`l Avcwb-

- gj`vqtbj KvR eY`v Ki`Z cvi`teb;
- gj`vqtbj cKvitf` D`j`L Ki`Z cvi`teb;
- gj`vqb c`uqvri avc ,tj vi weeiY w`tZ cvi`teb Ges
- gj`vqtbj bwiZgvj v weeZ Ki`Z cvi`teb|

gj`vqtbj KvR

gj`vqb GKwU e`vcK c`uqv| tKej gvI` uk`qv_xp` Av`bi cwi gvcB gj`vqtbj KvR bq, hwi I Avgit`i MZvbYmZK uk`qv e`e`vq gj`vqb gj`Z G At`_e`euZ ntq _v`K| uk`qv_xp` AvPi`Yi , YMZ Ges cwi gvYMZ Df`q cKvi wePvi we`kdt`Yi gva`tg gj` Av`ivc Kiv gj`vqtbj KvR| wbt`P mst`qtc gj`vqtbj KvR m`u`tk`Av`tj vPbv Kiv nj |

gj`vqtbj KvR

- uk`qv_xp` AvPi`Yi weifb`e`enk`to`i (Avb, `qvZv, `wofw` I gj`teva) weKv`tk w`K wbt`Rbv c`vb;
- uk`qv_xp` ukLbms`uk`w mej Zv I `qvZv wPw`yZKiY;
- ukLb-tkLv`bv c`uqvri tKvb ch`q wbi vggqj-K e`e`vi c`qvRb Av`Q Zv wPw`yZ Kiv;
- uk`qv_xp` cwi gvR`B I gv`bvqtbj w`K wbt`Rbv c`vb;
- uk`qv_xp` ukLb Awf`AZvms`v`š`Pwv`v c`t`Y mniqZv c`vb;
- uk`qv_i j`q` AR`b uk`qv_xp` i D`y` Kiv;
- ukLb-tkLv`bv Kvh`e`ij cwi Pij b`iq uk`qv`K`i Kg`qvZv hvPvB Kiv Ges ukLb miv`M` I tk`Yx Kvh`e`tgi Kvh`w`i Zv hvPvB;
- uk`qv`vb c`w`Zi gv`bvqtb Ges
- Av`vR`bi cvkvc`uk` uk`qv_xp` mnRvZ , Yveij thgb-`wofw` , Af`vm, Dcj w`KiY qvZv, Kvh` qvZv BZ`w` i wbi f`Y|

gj`vqtbj cKvitf`

gj`vqtbj e`vcK KgRvU m`u`v`tb weifb`e`ait`bi c`uqv Abv`Z ntq _v`K| gj`vqtbj weifb`e`ai b ,tj v nj -

uk`qv_xp` mej Zv I `qvZv wPw`yZ K`i

(K) WwqMbw`K (Diagnostic) gj`vqb: ukLb-tkLv`bv Kvh`e`tgi i`i`Z mvariYZ GiU Abv`Z nq| Gi Df`ik` nj uk`qv_xp` ev tk`Yxi mej Zv I `qvZv wPw`yZ K`i tm Abv`qx ukLb-tkLv`bv Kvh`e`g c`w`e`v`tmi gva`tg uk`qv_xp`K c`qvRbxq Avb, `qvZv I `wofw` AR`b mniqZv Kiv|

**MVbgj K Dbqtb
mnvqK**

(L) MvibK (Formative) gj`vqb: mnv eQi aġi cV Pj vKvj xb mgġq ukġlv_xp i AvPiġYi weifbæw ġKi weKiv ev eaB mæúġK[©]AeinZ nl qvi Rb` avivevnnKfvte th gj`vqb Kiv nq ZvB nj MvibK gj`vqb | G aiġbi gj`vqb ukġlv_xp MVbgj-K Dbqtb mnvqZv Kġi | cġ_ugK ġi cġvj Z avivevnnK gj`vqb GK aiġbi MvibK gj`vqb | GQvor mnvinnK ev gvmK AbjġZ Km tU÷ I MvibK gj`vqb |

**mweK AMMvzi
cwi gvc Kġi**

(M) cġŠK (Summative) gj`vqb: GKiv ubw B mgġqi ukLb-ġkLvġbv Kvġġg ġkġl weifbæw elġq ukġlv_xp ukLb AMMvzi hvPvBġq AbjġZ c×vzi bvgB nj cġŠK gj`vqb | GġZ ukġlv_xp i mveġ AMMvzi cwi gvc Kiv nq | we`ij ġq cġvj Z IvbġmK I ewl ġ cixġlv, GmGmm, GBPGmm cixġlv cġŠK gj`vqġbi D`vniY |

ukġlv_xp KwZzġ; gj`vqġbi wZb aiġbi gj`vqbB , iæzcY[©]

gj`vqġbi avc

cġeB Dġġ Kiv nġqġQ gj`vqb GKiv mvgvMġK I Rvġj cġqv | ZvB GġK mv_ġfvte Kvġġi KiġZ nġj AġbK tevk mġvq nġZ nte | we`ij ġq nVv GKiv b cixġlv wġq ev weifġB ukQycPóvi gvaġg Avi hvB tnvK gj`vqb mv_ġfvte Kvġġix nġZ cvġi bv Ges Gi , YMZgġġbi I wqšY mæe bq | Gi Rb` cġqvRb mvgÄm`cY[©]Kg[©]cwi Kġi bv Ges tm Abġvqx gj`vqb cġqvvi ev`evq | gj`vqb cġqvvi avc , ġjv nj -

**gj`vqb cġqvvi
avcmgġ**

1. maviY Dġġk` wPvYzKiY I eYBv;
2. weġkI Dġġk` wPvYzKiY I eYBv;
3. gj`vqb ġKŠkj wbeġPb ev DTMġeb;
4. gj`vqb ġKŠkj cġqvM Ges
5. gj`vqb dj vġj wvWe`vK wġmġe e`envi |

gj`vqġbi weifbæwġci cvi`úwi K mæúK[©]ġbġPi wġġġ t`Lvġbv nj |

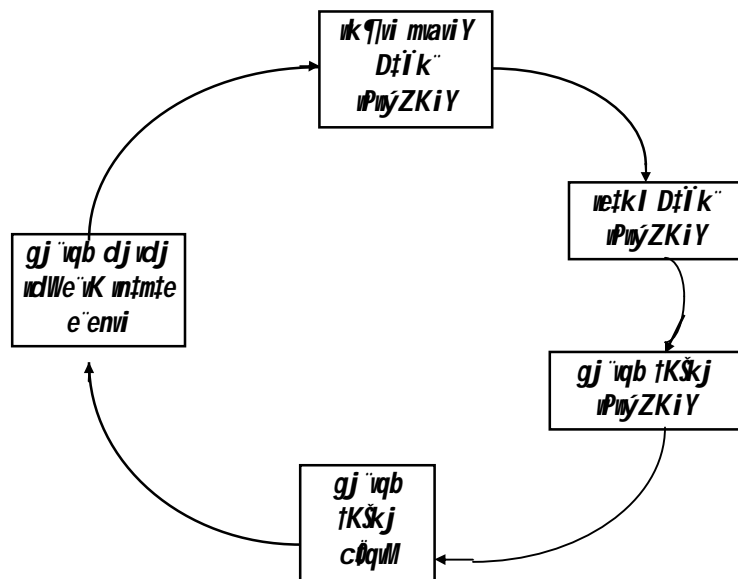

OK 5.2-1 : gj`vqġbi weifbæw

1/ **mvaviY Dfík` PnyZKiY I eYb:** GuU gj`vqtb cŭg avc| G chŷq Kx gj`vqb Kiv nte Zv PnyZ KiZ nte| A_ŷ ūbaŷiZ ūeltqi cVb cVtbi gva`tg mvaviYfite ūkŷv_xP AvPiŷYi Kx cwi eZb nte Zv G chŷq ūbaŷiY I eYb KiZ nte|

2/ **metkl Dfík` PnyZKiY I eYb:** G chŷq cteŷbaŷiZ mvaviY Dfík` , tj vtK tft½ metkl Dfík` Z_v AvPiŷYK Dfík` cKvk KiZ nte| GtZ Kti ūkŷv_xP AvPiŷYi cwi eZb `beŷK Dcvŷq cwi gvc Kiv mæ nte| AvPiŷYK Dfík` , tj v egg (Bloom) I Zui mnthvMx` i cŎE Taxonomy-i ūfŷtZ ūbaŷiY KiZ nte| A_ŷ AvPiŷYK Dfík` , tj v Avbgj-K (cognitive), AbŷŷZgj-K (affective) Ges `ŷZvqj-K (psychomotor) nte| GtZ Kti ūkLb AMŷŷiZi mvgŷŷK cwi gvc mæ nte| G `liŷU gj`vqtb Ab`Zg , iæZcY`fi |

3/ **gj`vqb tKŷkj ūbePb ev D`teb:** gj`vqtb ZZxq chŷq metkl ev AvPiŷYK Dfík` , tj v cwi gvtci Rb` h_vthvM` tKŷkj ūbePb KiZ nte| ūkŷv_xP i ūkLb AMŷŷiZ ev KŷZi cwi gvtci ūefbæAvaybK tKŷkj I Afŷŷv itqtQ th , tj v mæutK` cieZx`cvtV Avtj vPbv Kiv nte| G , tj vi GK GKŷ GK aiŷi AvPiŷYK cwi eZb cwi gvtci Rb` DcŷhMx| Gmtei gta` t_tK Dchŷ cwi gvc tKŷkj I Afŷŷv ūbePb DciB ūkŷv_xP KŷZi gj`vqtb mv_ŷZv ūbfP Kiŷe|

4/ **gj`vqb tKŷkj cŷqM:** G chŷq ceŷZx`fi ūbePZ cwi gvc tKŷkj , tj v chŷqŷtg cŷqM Kti Z_` msMh KiZ nte| thŷZzgj`vqb GKŷ mvgŷŷK cŷqM, tmŷZzhZ teŷk cwi gvY Z_` msMh Kiv hte gj`vqb ZZ mv_ŷ nte|

5/ **gj`vqb djvdj ūdWe`ik mntte e`envi:** GuU gj`vqtb meŷkl `fi | G chŷq gj`vqtb cŷB djvdj i ūfŷtZ t`Lŷ nte ūkŷvi Dfík` , tj v AmRZ nte| ūkŷv A_ŷ ūkLb AMŷŷiZ tKv_vq NvUŷ itqtQ? Avi GuvB nte`Q gj`vqtb cKZ.j ŷ, hvi ūfŷtZ cieZx`kŷv Kvhŷtgi cŷqRbxq cwi eZb I gvtbvŷb KiZ nte|

th tKv gj`vqb Kvhŷg mv_ŷ, KvhRix Ges gvbmæubentZ ntj GB avc , tj vi ga` ŷ`tg Zv cwi Pŷj ZntZ nte| Ab`_vq gj`vqtb , YMZgvb e`vnZ nte hv ūkŷvi mvgŷŷK Dfík` ARŷ mnvqK nte bv| gtb ivLteb, gj`vqtb Dfík`B nte`Q ūkŷvi j ŷ ARŷ dj chŷntqtQ ūkŷv Zv cwi gvtci gva`tg ŷmæŷŷiMhY Kiv|

gj`vqtb bŷZgvj v

gj`vqtb ūkŷvŷZgvj v itqtQ hv metkl fite AbŷZ ntj gj`vqtb KivŷU Dfík`gŷx I gvbmæubæKiv mæ nte:

gj`vqtb bŷZgvj v

1. ūkŷvi Dfík` , ūkLb-ŷkLvtbv Kvhŷŷj , ūkLb AmfAZv Ges gj`vqtb cvi `ŷvi K mæutK`gj`vqtb iŷŷi fŷj fite ūtePbv KiZ nte|
2. Kx gj`vqb Kiv nte Zv cŷtgB PnyZ I eYb KiZ nte|

ġ Ae GWKkb

3. $\text{uk}^{\text{q}}\text{vi}$ $\text{weifbæD}^{\text{t}}\text{ik}^{\text{i}}$ $\text{Pvin}^{\text{`}}$ vi $\text{wfi}^{\text{E}}\text{tZ}$ $\text{gj}^{\text{`}}$ vqb tK^{S} kj wba^{f} Y Ki^{t} Z n^{t} e |
4. mme^{R} $\text{gj}^{\text{`}}$ vq^{t} bi $\text{Rb}^{\text{`}}$ $\text{weifbæai}^{\text{t}}$ bi $\text{gj}^{\text{`}}$ vqb tK^{S} kj $\text{e}^{\text{`}}$ eüZ n^{t} Z n^{t} e |
5. $\text{gj}^{\text{`}}$ vqb tK^{S} kj , tj vi mej I ` g^{f} w K $\text{m}^{\text{`}}$ ú^{t} K^{q} m^{t} PZb _ vK^{t} Z n^{t} e | G^{t} Z K^{t} G d j c^{h} e v ` é vqb $\text{m}^{\text{`}}$ e n^{t} e |
6. $\text{gj}^{\text{`}}$ vqb^{t} K uk^{q} vi D^{t} $\text{ik}^{\text{`}}$ AR^{f} bi GK^{u} avivewinK Dcvq in^{t} m^{t} e wetePbr Ki^{t} Z n^{t} e |

G c^{t} v $\text{gj}^{\text{`}}$ vqb $\text{m}^{\text{`}}$ ú^{t} K^{Z} K^{t} qK^{u} tg^{S} ij K avi Yv , thgb - $\text{gj}^{\text{`}}$ vq^{t} bi KvR , aib , avc I b^{m} Zg^{v} v $\text{m}^{\text{`}}$ ú^{t} K^{q} Av g iv AewinZ nj vg | uk^{q} iv x^{p} KwZZ ; $\text{gj}^{\text{`}}$ vq^{t} b G , tj vi h _ vh _ Abyri Y $\text{gj}^{\text{`}}$ vq^{t} bi , YMZg vb wb^{u} DZK i^{t} Y mnvqK n^{t} e | cieZx^{q} c^{t} v uk^{q} iv x^{p} KwZZ ; $\text{gj}^{\text{`}}$ vq^{t} bi weifbæ^{t} K^{S} kj I nmZqvi $\text{m}^{\text{`}}$ ú^{t} K^{q} Av g iv AewinZ ne |



c^{t} v w^{E} i $\text{gj}^{\text{`}}$ vqb 5.2

A) msw f B D^{E} i c^{k} æ

1. $\text{gj}^{\text{`}}$ vq^{t} bi KvR Kx ?
2. MVbg j -K I c^{h} S K $\text{gj}^{\text{`}}$ vq^{t} bi g^{t} $\text{a}^{\text{`}}$ c^{v} $\text{R}^{\text{`}}$ wb ifc Y Kiab |
3. Wvq M^{t} b w -K $\text{gj}^{\text{`}}$ vq^{t} bi D^{t} $\text{ik}^{\text{`}}$ Kx ?
4. $\text{gj}^{\text{`}}$ vqb GK^{u} m v g w M^{K} I R^{u} Lj c^{h} u q v tKb ?
5. $\text{gj}^{\text{`}}$ vqb c^{h} u q v avc , tj v Kx ?

Av) iP b v g j -K c^{k} æ

1. GK^{u} m v R I K v h R i x $\text{gj}^{\text{`}}$ vqb c^{h} u q v avc , tj v eY^{b} v Kiab | G avc , tj v h _ vh _ f v t e Abyr Z bv n^{t} j Kx Am v e av n^{t} Z c^{t} v i - e^{v} L^{v} v Kiab |
2. $\text{gj}^{\text{`}}$ vq^{t} bi b^{m} Zg v , tj v Kx ? Av g v^{t} i $\text{t}^{\text{`}}$ t k uk^{q} iv x^{p} KwZZ ; $\text{gj}^{\text{`}}$ vq^{t} b Zv KZUv Abyr Z n^{t} q _ v^{t} K G $\text{m}^{\text{`}}$ ú^{t} K^{q} Av c b v i Aw f g Z w j L b |

cw 5.3

ጠባላ ጽሑፍ ለግብይት ጥናት ዘርፍ ደረጃ

[Techniques and Tools for Evaluation of Students' Achievement]

ጥያቄ

GB ርዕስ ጥያቄ

- ጠባላ ጽሑፍ ለግብይት ጥናት ዘርፍ ለሌሎች ጥያቄዎች ለመጠቀም ማቻላቸውን ማረጋገጥ፤
- ግብይት ጥናት ለማድረግ ለሌሎች ጥያቄዎች ለመጠቀም ማቻላቸውን ማረጋገጥ፤
- ጠባላ ጽሑፍ ለግብይት ጥናት ዘርፍ ለሌሎች ጥያቄዎች ለመጠቀም ማቻላቸውን ማረጋገጥ፤

ጠባላ ጽሑፍ ለግብይት ጥናት ዘርፍ ለሌሎች ጥያቄዎች ለመጠቀም ማቻላቸውን ማረጋገጥ፤ ግብይት ጥናት ለማድረግ ለሌሎች ጥያቄዎች ለመጠቀም ማቻላቸውን ማረጋገጥ፤ ጠባላ ጽሑፍ ለግብይት ጥናት ዘርፍ ለሌሎች ጥያቄዎች ለመጠቀም ማቻላቸውን ማረጋገጥ፤

ግብይት ጥናት ዘርፍ

ግብይት ጥናት ዘርፍ ለሌሎች ጥያቄዎች ለመጠቀም ማቻላቸውን ማረጋገጥ፤ ግብይት ጥናት ዘርፍ ለሌሎች ጥያቄዎች ለመጠቀም ማቻላቸውን ማረጋገጥ፤ ግብይት ጥናት ዘርፍ ለሌሎች ጥያቄዎች ለመጠቀም ማቻላቸውን ማረጋገጥ፤

ጥያቄ: ጠባላ ጽሑፍ ለግብይት ጥናት ዘርፍ ለሌሎች ጥያቄዎች ለመጠቀም ማቻላቸውን ማረጋገጥ፤ ግብይት ጥናት ዘርፍ ለሌሎች ጥያቄዎች ለመጠቀም ማቻላቸውን ማረጋገጥ፤ ግብይት ጥናት ዘርፍ ለሌሎች ጥያቄዎች ለመጠቀም ማቻላቸውን ማረጋገጥ፤

ግብይት ጥናት ዘርፍ: ግብይት ጥናት ዘርፍ ለሌሎች ጥያቄዎች ለመጠቀም ማቻላቸውን ማረጋገጥ፤ ግብይት ጥናት ዘርፍ ለሌሎች ጥያቄዎች ለመጠቀም ማቻላቸውን ማረጋገጥ፤ ግብይት ጥናት ዘርፍ ለሌሎች ጥያቄዎች ለመጠቀም ማቻላቸውን ማረጋገጥ፤

ግብይት ጥናት ዘርፍ: ግብይት ጥናት ዘርፍ ለሌሎች ጥያቄዎች ለመጠቀም ማቻላቸውን ማረጋገጥ፤ ግብይት ጥናት ዘርፍ ለሌሎች ጥያቄዎች ለመጠቀም ማቻላቸውን ማረጋገጥ፤ ግብይት ጥናት ዘርፍ ለሌሎች ጥያቄዎች ለመጠቀም ማቻላቸውን ማረጋገጥ፤

(1) iPbvj-K Afxŷ: G RvZxq cŷkē DĒi `xNnq| cŷkē DĒti, evK`i MVtb I welqe`tZ e`w³`vZšj Qvc `vtK| cixŷK i e`w³ cv_ŷK`i KviŷY baf cŷvbi tŷŷ ZviZg` nq| GgbwK mgtqi cv_ŷK`i KviŷYI GKB cixŷK i t`q baf i e`earb ntq hvq| GB Amŷear `i-Kivi Rb` iPbvagi`cŷkēK KtqKwU tŷvU tŷvU fvŷM wef³ Kiv nq Ges cŷZwU Astki DĒi tgvUvgŷ mŷw`ŷ nq| GtZ e`w³ cv_ŷK`i cŷve Govtbv hvq|

(2) `beŷK Afxŷ: `beŷK cŷkētjv wefbaeKg ntZ cvti | thgb- eŷ ubeŷbv, nŷbv, mZ`-wg`v, wj KiY Ges m`úŷŷRiY| G aŷbi cŷkē DĒi mŷw`ŷ nq| dtj e`w³ cv_ŷK`i KviŷY djvdj cŷmeZ nq bv|

iPbvj-K I `beŷK Afxŷvmgŷni cŷqb c`wZ Ges mŷear-Amŷear m`úŷK`wKŷv cwi gvc I gj`vqŷbi wefbaeBtq we`wiZ AvtjvPbv itqŷQ| wKŷK KZR.KwZZ; Afxŷv cŷqŷb G mKj wel tqi cŷZ tLqj ivLv DŷPZ|

(L) tgŷLK Afxŷ: GtZ tgŷLK wRÁvmvi gva`tg wKŷv_xP Ávb, cviMZv, `ŷZv, `wŷfŷ, gZvgZ BZ`w` hvPvB ev cwi gvc Kiv nq| G Afxŷvi gva`tg Afxŷv_xP `šbkw³, evPbŷfŷ, evMZv, D`PwiY, fvŷvi cŷqvm BZ`w` i cvi`wZv ev `ŷZv mnŷRB hvPvB Kiv hvq|

(M) Kgŷúv bx Afxŷ: wKŷv_xP Ggb AŷbK AwfÁZv ev `ŷZv itqŷQ hv Ktŷŷ gva`tg cwi gvc Kiv tkŷ| thgb- KŷúDUvi e`envi Kti powerpoint presentation `Zwi Kivi `ŷZv ev mZvŷi i `ŷZv, tgŷLK ev wj wLZ cixŷv w`tq cwi gvc Kiv hvq bv| tckwMZ Ges e`enwi K wKŷvi tŷŷŷ thgb- tcb Pjvŷbv, nŷZi KivR, ivbŷ weÁvbi e`enwi K KivR BZ`w` tZ Kgŷúv bx Afxŷv cŷqvm mteŷŷg|

(N) chŷŷYvj-K Afxŷ: wKŷv_xP KwZZ; gj`vqŷb GuU tek `iaZcŷ`fŷgKvi `vex`vi | hLb wKŷv_xP tKvb AvPiY cŷ`ŷ ev ctivŷŷfŷe j ŷ Kti gj`vqŷ Kiv nq ZLb ZvŷK chŷŷYvj-K Afxŷv etj | e`w³tZi AŷbK msj ŷŷ, thgb- tbZZ;vb, AvbMZ, `wqZŷeva, gj`ŷeva, wbgvbwŷZv BZ`w` gvbweK `Yvevj G tKŷkj e`envi Kti gj`vqŷ Kiv hvq|

(O) `wjj `ŷteR wbiŷŷvj-K Afxŷ: hLb tKvb wKŷv_xP `ŷZv ev cviMZvi miwmi gj`vqŷ bv Kti Zvi weMZ Ktŷŷ djvdj i tiKWŷ`tK gj`vqŷ Kiv nq ZLb ZvŷK `wjj `ŷteR wbiŷŷvj-K Afxŷv etj | GtZ wKŷv_xP tivRbvŷPv, avivwvK Z`weeYx, evrmi K cvŷVvbwZi cŷZte`b BZ`w` tiKWŷbiŷŷv Kti wKŷv_xP `Yvevj ev `ŷZv m`úŷK`m`všŷŷMŷY Kiv nq|

KwZZ;gj`vqŷ tKŷkj I Afxŷv ubeŷŷb wteŷPZ wclq

wKŷv_xP KwZZ; cwi gŷtci wefbaeAfxŷv I tKŷkj `tjvi DcŷwMZv mKj tŷŷŷ mgvb bq| wKŷv_xP wfbewfbae`enkó` cwi gŷtci GK GKwU Afxŷvi cŷqvmKxj Zv GK GK iKg| Dchŷ gj`vqŷ tKŷkj ubeŷŷbi DciB wKŷv_xP KwZZ; gj`vqŷbi `YMZgvb

AþbKlmb wbfþkj | wþP KtqKwU ckleDīwcz nj hv Dchþ Afxᚼv Ges tKŠkj
wYþq mrvqK nte | ckleþj v nj :

- 1| Kx DþĪ þk'' gj''vqb Kiv nte ?
- 2| wv̄ ʈ DþĪ k'' gj''vqþbi Rb'' wþPi tKvb Afxᚼv e''eüZ nte?
 - wj̄ mLZ cixᚼv
 - tgšLK cixᚼv
 - Kgᚾúv`b KiþZ w`tq
 - chþeᚼY
 - `wj̄ `´þeR wvixᚼv
- 3| hv̄ wj̄ mLZ cixᚼv tbi qv nq Zþe tmUv iPbvqj-K nte, bwiK `beʈ³K nte?
- 4| wv̄āni Z Afxᚼv wU Av`kᚾqZ nte, bwiK wKᚼK wþR cÜZ Kiþeb?
- 5| hv̄ wKᚼK wþR Afxᚼv `Zwi Kþib Zþe tmUv Kx aiþbi nte?
- 6| hv̄ Av`kᚾqZ Afxᚼv e''eüZ nq Zþe tmUv tKv_v t_þK msmð Kiv nte|
- 7| hv̄ wj̄ mLZ Afxᚼvi evBþi Ab'' tKvb Afxᚼv e''eüZ nq Zþe tm_vj̄ v wKfvte `Zwi
Kiv nte ?

wKᚼv_xþ KwZZ; gj''vqþb Dchþ tKŠkj | Afxᚼv wbeþþb GKwU , iazcyelq | Kvi Y
wKᚼvi mKj DþĪ k'' GKB tKŠkj ev Afxᚼv ʈv̄v gj''vqb Kiv m=þ bq, Avevi DīPZI
bq| GRb'' gj''vqþbi tᚼĪ meēġ cŋqvRb DþĪ k'' wvifcy Kiv hv̄þZ Kþi DþĪ þk''i
mif_ gj''vqb tKŠkj wU Lvc Lvq| D`vni Y`þfc Avcvb hv̄ wKᚼv_xþ Pj wZ fvlvq K_v
ejvi `ᚼZv cwigvc KiþZ Pvb Zþe tm tᚼĪ tgšLK cwigvc DĒg| Avevi
wKᚼv_xþ i gþa'' tbZþzi , Y cwigvc KiþZ ntj Zv`iþK Kgᚾúv`b KiþZ w`tq
chþeᚼY Kiv DĒg|



cvþwēi gj''vqb 5.3

A) msv̄þB Dēi ckle

1. wKᚼv_xþ KwZZ; ej þZ Kx eþvq ?
2. Afxᚼv KvþK etj ?
3. `agj''vqb tKŠkj wU eYþv Kiab| GwU wKᚼv_xþ AvPiþYi tKvb w`KuUþK mgþ Kþi?
4. Kvhᚾúv`bx Afxᚼv Ges chþeᚼYgþ-K Afxᚼvi cv`R'' Kx ?
5. wKᚼK wvqZ KwZZ; Afxᚼv Ges Av`kᚾqZ KwZZ; Afxᚼvi cāvb cv`R'' Kx ?
6. wKᚼv_xþ KwZZ; gj''vqþb cŋqvMþhM'' Afxᚼv_vj̄ vi bvg wj̄ Lþ|
7. wKᚼv_xþ KwZZ; gj''vqþb chþeᚼYgþ-K Afxᚼvi , iaz; e`vL`v Kiab|

Av) iPbvqj-K ckle

1. wKᚼv_xþ KwZZ; gj''vqþb e''eüZ Afxᚼv_vj̄ vi wēi Y w`b|
2. KwZZ; gj''vqþbi Rb'' Dchþ tKŠkj | Afxᚼv wbeþþb wēþēPZ wēlq_vj̄ v eYþv
Kiab| wKᚼv_xþ tKvb wv̄ ʈ AvPiY gj''vqþb Dchþ tKŠkj MþxZ bv ntj Kx
Amþeav nþZ cvþi - D`vni Ymn e`vL`v Kiab|

cW 5.4

uk9iv_xP KuZZi gj`vqb c9uqvi `eiko`, m9ve×Zv I ,YMZ gvtbvbqb : tcl9ivU eisj v`k

[Evaluation of Students' Achievement - Characteristics, Limitations and Qualitative Improvement : Context Bangladesh]

D9ik`

GB cvW tk9I Av9ib-

- eisj v`tki c9ij Z uk9iv e`e`vq me`g9v uk9iv_xP gj`vqb c9uqvi `eiko` D9j- L Ki9Z cvi9eb;
- D9j- uLZ gj`vqb c9uqvi m9ve×Zv uP9yZ I c9ve eY9v Ki9Z cvi9eb Ges
- uk9iv_xP KuZZi gj`vqb c9uqvi ,YMZ g9v ubq99Yi Dcvq ub9 R Ki9Z cvi9eb/

uk9iv_xP ukLb AM9iZi gj`vqb uk9iv e`e`vi GKiu A9e9`Q` Ask Ges Zv c9ixbK9j t_9KB Ae`v9Z it9tQ, hu I Gi `9fc tm mg9q uQj ufb9eK9j| eZ9vK9tj uk9ivi b9v9ea c9vi I meK9t9ki d9j c9ixb cix9iv c×uZi `9j Rb9ub9t9tQ Av99bK gj`vqb c×uZ| Av9v9`i t_9k uk9iv_xP KuZZi gj`vqb c×uZI me9fb9e9i eZ9 Ges ms`v9i i gva`9g eZ9vb Ae`vq Dcb9Z nt9tQ Ges GLb ch9i G me9t9 Pj 9t me9fb9e9i9v I mg99iv| G tcl9ivU eZ9vb cv9v eisj v`tki uk9iv e`e`vq c9ij Z uk9iv_xP gj`vqb c×uZi `eiko`, m9ve×Zv Ges uk9iv_xP KuZZi gj`vqb c9uqvi ,YMZg9v Db9t9bi Dcvq m9u9K9 Av9j vP9v u9ice× nt9tQ| G Av9j vP9v gj`Z c9u9K I gva`9gK `9i i gj`vqb c×uZ9KB c9avb` t_ I qv nt9tQ|

eisj v`tki uk9iv_xP gj`vqb c9uqvi `eiko`

1. eisj v`tki c9ij Z m9v9Y uk9iv e`e`vq c9u9K `9i (1g-5g tk9x) eZ9v9b av9ve9nK I m9v9u9K gj`vqb c×uZ P9j ynt9tQ| RvZ9q uk9iv9g I cvW`c9K te9w`c9e9Z9 RvZ9q uk9iv9g Ab9v9q c9g I u9Z9q tk9x9tZ m9u9Y99c av9ve9nK gj`vqb c×uZ Ges ZZ9q t_9k cA9 tk9x ch9i av9ve9nK I m9v9u9K gj`vq9bi (eQ9i uZ9u) mg99g GKiu u9k`c×uZ P9j y9t9tQ|
2. RvZ9q uk9iv9g I cvW`m9P c9Z9e`b Ab9v9q ub9g9v9u9K `9i (69-8g tk9x) c9u9K `9i i gZ av9ve9nK gj`vq9bi e`e`v it9tQ| GKiu cvW ev Aa`vq tk9I Gai9bi gj`vqb Kiv hu9e| tmB mu9_ m9v9nK Ges g9m9K gj`vq9bi m99h9M it9tQ Ges tk9v tk9v `9j Zv ub9u9Z9v9e K9i _v9K| Z9e c9Z9u gva`9gK me`v9t9 K9c99 uZ9u c9avb cix9iv (`9j m9v9u9K Ges GKiu em9 R cix9iv) Ab9v9bi me9v it9tQ| P9v9i gj`vq9bi Rb` `9j m9v9u9K I em9 R cix9iv g9a` b99i Ab9v9 nj 40% Ges 60%| G9v9e m9v9u9K I em9 R cix9iv c9b djv9t9i Dci ufb9E K9i GKRB uk9iv_xP kieZ99tk9x9tZ c9v9e9 t_ I qv nq| gj`vq9b iP9v9j-K I `be99K Af9iv e`e9Z nt9 _v9K| iP9v9j-K c9e`y9K9 nq- ms99B D9i I `xN`D9i| `be99K Af9iv9 A9if9 it9tQ e9 ub9e9b9 I u9j KiY RvZ9q Av9t9u9|

**Ávbi cniġvc I
`šjZ ibfP RvZiq cġe**

4. eZġvrb cPij Z gj`vqb c×wZ cāvbZ Ávbgj-K| tKej AmRZ ÁvbB GtZ cniġvc Kiv nq| `ŋZv, `wofw/2 cniġvrci tZgb tKvb e`e`v eZġvb gj`vqb c×wZtZ tbB| Ávbgj-K tŋtġi gta` Avevi `šjZibfP (recall) RvZiq cġeteik ntq `vK| Abgveb (comprehension) Ges cġqvMgj-K (application) cġe hrmvġvb` Kiv ntj I Ávbi D`PZi tŋtġi Ges cġqvMgj-K cġeGtKerġi Kiv nq bv ej tj B P tj | A_P wġŋv_xP e`w³tZji mmeR weKvġki cniġvc Ki tZ ntj Ávbi cġZw tŋtġiKB cġavb` t` I qv DvPZ|

**AvanbK I
gġbweÁvbm²Z
tKŠkj i Afie**

5. AvanjK wġŋvq wġŋv_xP gj`vqġbi Rb` weifbæ AvanjK I gġbweÁvbm²Z tKŠkj I DcKiY D`mæZ ntqtQ| Dbæ Ges AtbK Dbqbkj t`tk G_tjv e`eüZl nt`Q| wKŠ` Avgvġ`i gj`vqb e`e`v GLbI Gtŋtġi wġŋvq AvtQ Ges Avgvġ`i t`tk e`eüZ gj`vqb nmZqri GLb chšlmbvZb cġeabfP|

**wġŋK vbiġZ
A-Av`kġqZ Afxŋv**

6. Avgvġ`i we`ij q_tjvZ Ges cvej K cixŋvq th mKj cġeKiv nq Zv cġivcvi wġŋKġ`i ōviv `zwi A-Av`kġqZ Afxŋv| dtj G_tjv wġŋv_xP AvPiwK cni eZġbi h_vh_ gj`vqġb KZUv mrvqK tm m²útk`cġeġtqtQ| weġki weifbæ t`tk gj`vqb tmj MVtbi gva`tg wġŋv cġZōvġbi Rb` Av`kġqZ Afxŋv cġvq I mieivni e`e`v `vKtj I Avgvġ`i t`tk GLb chšl tm aġbi tKvb cġZōvb tbB| dtj wġŋKġ`i cġZKZ.cġB GKKfġte e`eüZ ntq `vK| wKŠ`wġŋKġ`i gj`vqb m²úwKZ AvanjK a`vb avi Yvi Afġte cġæev Afxŋv ĪwUgŷ nq bv| dtj gj`vqb h_vh_ Dġġk` ARġb e`_ŋq|

**h_v`Zv, wbfPthM`Zv
I cġqvMkxj Zvi Afie**

7. cniġvchšj;wntmte GKw m²fŋv h_v`Zv(validity), wbfPthM`Zv (reliability), cġqvMkxj Zv (applicability) BZ`w` `enkó` `vKv DvPZ| wKŠ` Avgvġ`i t`tk e`eüZ Afxŋv_tjv cġŋvYcŌB e`w³ I weġkIÁġ`i ōviv m²wK c×wZtZ cġvZ bv nI qv Afxŋv_tjv ĪwUgŷ nq bv|

**t`wis-Gi h_vh_
e`vL`vi Afie**

8. Avgvġ`i gj`vqb c×wZtZ wġŋv_xP i gj`vqġb cŌB djvdj t`wis Gi th e`e`v itqtQ tmvI ĪwUgŷ| GLvġb cixŋvq wġŋv_xP mvari Yfġte cvk ev tdj b²t t` I qv nq| wKŠ` Gi tKvb e`vL`v `vK bv| dtj wġŋv_x`cvk Ki tġ I Zv KZUv ġvbm²ubæZv tevSv hvq bv|

**wbiġqġj K e`e`v
MġtYi mšhvMi
Afie**

9. eZġvrb cvk ev tdj i gva`tg wġŋv_xP wġŋv_xP AMMwZ gj`vqġbi th e`e`v cPij Z itqtQ ZvtZ th wġŋv_x`tdj b²t cvq Zvi Rb` cġqvRbxq wbiġqġj-K e`e`v MġtYi mšhvM tbB| A_P GtZ wġŋv_xP `ŋZvB tKej wPvYZ nq, Zv `hKġtYi cġqvRbxq mšhvM Avgvġ`i gj`vqb c×wZtZ tbB| GLvġb Dġġl` th, cġwġK `ġi i gj`vqb b²wZġvġq wbiġqġj-K e`e`v MġtYi m²úó Dġġl` `vKtj I Zv ev`ġe KZUv AbvZ nt`Q tm m²útk`cġeġtqtQ|

Dcwi D³ KviġY Avgvġ`i cġwġK I gva`wġK `ġi i eZġvb gj`vqb e`e`vġK h_vh_ ġvbm²ubæjv hvq bv| dtj wġŋv tŋtġi D`mZ nt`Q b²vvi Kg mġm`v- hv mġvMġKfġte wġŋvġi `YMZġvġK cġfweZ Ki tQ| m²úúZKġvġj Gm Gm w I GBP Gm w cixŋvq bKġj i e`vck mġġivn Ges cixŋvq e`vck AKZKvġvivi nvi wġŋv e`e`vi `ŋP w`K_tjvġK AZ`šl `úofġte wPvYZ Ki tQ| wġŋvġi `YMZ ġvb wġqšY eZġvb mġġi Ab`Zġ `we| gj`vqb c×wZ nt`Q th tKvb wġŋv e`e`vi ŌwKb`ġġc| ġwU hv wġŋvġi

- gj`vqtb c`B dj v dj tKej tNvIYv Ki t j B nte br | tm Ablyvqx uk`v_xp` i Rb` c`qvRbxq w b ivgggj-K e`v Ges uk`v Kihp`tgi c`qvRbxq cwi gvR` I gvtvbaq`bi e`v Ki t Z nte |
- gj`vqb c`uqvU thb c`v`nkZ gvb Ablyvqx cwi Pvi j Z nq tm j t`v` uk`vKt` i Rb` gj`vq`bi wvfbaw` tKi Dci c`k`vY I tckvMZ Dbq`bi e`v Ki t Z nte |



civ`vEi gj`vqb 5.4

A) msv`B DEi c`kæ

1. evsj v`tki c`u`gK t`i c`v j Z gj`vqb c`x`Zi eY`v w` b |
2. wbgvva`v`gK Ges gva`v`gK ch`qi gj`vqb c`x`Z Kx ai`bi ?
3. Avgv` i t`tki gj`vqb c`x`Z`Z c`v`Z uk`v_xp` tKv w` Kiu gj`vqb Kiv nq Ges Kx fite Kiv nq?
4. ej v n`q`_v`K eZ`v`b c`v j Z gj`vqb c`x`Z Avbgj-K - tKb e`vL`v Ki ab |
5. GKiu myAfv`v`q Kx Kx `enkó`_vKv DvPZ? wKfite Zv wv`v`Z Kiv hvq ?

Av) iPbvj-K c`kæ

1. evsj v`tki uk`v_xp`gj`vqb c`u`qvi `enkó` Avtj vPv Ki ab |
2. evsj v`tk c`v j Z gj`vqb c`x`Zi m`gve`Zv`_tj v Kx? G`_tj v Avgv` i uk`v e`v`v`K wKfite c`v`v`Z Ki t Q?
3. gj`vqb c`x`Zi`_YMZgvb w`q`š`Yi Dcv`_tj v eY`v Ki ab |



Pov`š`gj`vqb 5

A) msv`B DEi c`kæ

1. uk`v gj`vqb Kx?
2. cwi gvc I assessment-Gi cv`R` w` Lj |
3. gj`vq`bi t`v`v` w`tkl D`t`k` w`v`ZKiY w`k`mi w`v`v`Z Ki t Z nte?
4. gj`vqb dj v dj w`v`v`K w`v`v` e`v`v` i c`qvRbxqZv Kx?
5. uk`v_xp` KuzZj; gj`vq`bi`_`^gj`vqb tK`skj w` eY`v Ki ab |
6. uk`v_xp` KuzZj; gj`vqb tK`skj I Afv`v` w`v`v`bi t`v`v` Kx Kx w`lq w`v`v`v` Kiv c`qvRb?
7. Avgv` i t`tk c`v j Z cix`v` c`x`Z`K cix`v`v`e`^ej v nq tKb?
8. ej v n`q`_v`K eZ`v`b c`v j Z gj`vqb c`x`Z Avbgj-K - tKb e`vL`v Ki ab |
9. evsj v`tki c`v j Z gj`vqb c`x`Zi`_YMZgvb w`q`š`Yi Pvi w` Dcv` m`v`v` k Ki ab |
10. GKiu myAfv`v`q Kx Kx `enkó`_vKv DvPZ? wKfite Zv wv`v`Z Kiv hvq?

Av) iPbvj-K c`kæ

1. gj`vqb Kv`K etj ? uk`v`v`Z gj`vqb I cwi gvtci cv`R` w` Lj |
2. gj`vq`bi KvR Kx? gj`vq`bi c`k`v`v` Avtj vPv Ki ab |
3. KuzZj; gj`vq`b e`e`v`Z tK`skj`_tj v Avtj vPv Ki ab | Avgv` i t`tk uk`v_xp` KuzZj; gj`vq`b Gme tK`skj`_tj v KZUv c`qvM n`v`Q Zv ch`j vPv Ki ab |
4. evsj v`tk c`v j Z gj`vqb c`x`Zi m`gve`Zv`_tj v Kx? G`_tj v Avgv` i uk`v e`v`v`K wKfite c`v`v`Z Ki t Q?
5. gj`vqb c`x`Zi`_YMZgvb w`q`š`Yi Dcv`_tj v eY`v Ki ab |

cW 6.1

ikLb-ikLvtbv mvgMöi avi Yv I tkYnefVM

[Concepts and Classification of Instructional Materials]

Dfik`

GB cW tkfi Avicwb –

- Instruction -Gi avi Yv e`3 KiZ cvi`eb;
- ikLb-ikLvtbv mvgMöi ej tZ Kx eSvq Zv e`vL`vi KiZ cvi`eb;
- ikLb-ikLvtbv mvgMöi tkYnefVM KiZ cvi`eb Ges
- ikLb-ikLvtbv mvgMöi wefbaeib Dfj tL KiZ cvi`eb/

Instruction Kx?

Instruction -Gi avi Yv

ikLb-ikLvtbv mvgMöi Bsti`R cöZkã ðInstructional Materialsöö/ Instruction n`Q GK ai`bi gvberq Kg`cöPön hvi gva`tg e`w3 ev ik`qv_x`öKvib ikQymk`L_v`K ev Zv`K tKvib ikQymkL`Z mnvqZv Kiv nq| GiU n`Q ikLb mnvqK Ggb ikQyNUbv ev weiq ev Kv`Ri mgwó hvi gva`tg ik`qv_x`öKvib_v`K| wefbaeai`bi Bw`q (t`Lv, tkvib, MÜ tbi qv, `r MhY Kiv I `úk`Kiv) e`enitii gva`tg ik`qv_x`öGB ikL`bi KvR m`úbæKiZ cvi`i | wbtPi w`f` Instruction ev ikLb-ikLvtbvi KtqKwU aib ev Dcivq m`ú`K`avi Yv t` I qv nj |

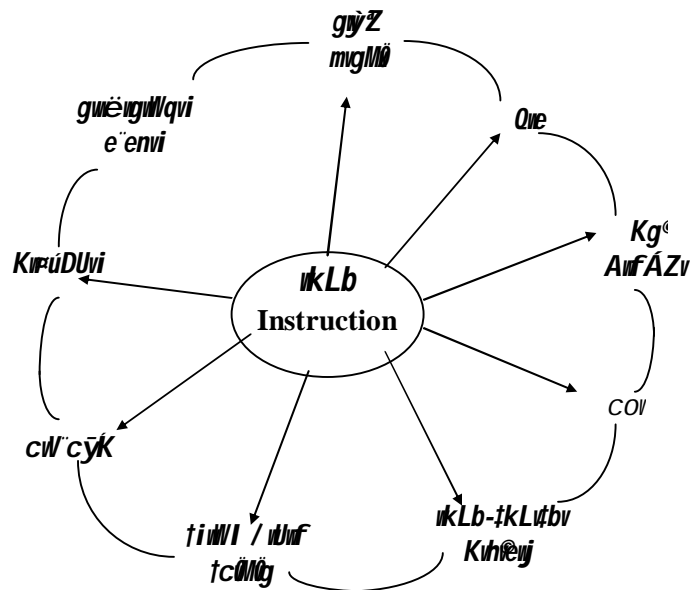

w`P` 6.1-1 : ikLb-ikLvtbvi aib ev Dcivq

**ඛLb-තLතb් mvgMබ්
aviYv**

ඛLb-තLතb් mvgMබ් Kx?

ceZx°Avtj vPbvq Avgiv tRතb්Q Instruction nj ඛQyNubv / weLq / KvතRi mgබ්
 hv ඛඹv ඛඹK Zvi ඛLතb mrvqZv Kති ev hvi gvaඹg ඛඹv_ඛඹL_ඛඹK| Avi mv_ඹ I
 Kvhඹi ඛLතb th mKj ඛඹv mrvqK DcKiy ev mvgMබ් cඹqRb nq tm_තj ඛඹK GKඹඹ
 ejv nq ඛLb-තLතb් mvgMබ්| A_ඹ ඛඹv_ඛඹZvi weifbæBබ්`ඹqi gvaඹg th mKj
 Dඹxcbv Mබ්Y Kති Zvi AvPiතY Bබ්Z cබ් eZබ් AvතZ cඹi, tm mKj Dඹxcbv mඹKvix
 gvaඹgඹK ඛLb-තLතb් mvgMබ් ejv nq|

ඛLb-තLතb් mvgMබ් තYvefMබ්

ඛLb-තLතb් mvgMබ් ඹඹඹQ weifbæaib| weතI Kති mඹúඹZKවතj weÁvb I cඹඹඹ^ඹ i
 AKඹbxq I we_ඹKි Dbබ්Zi dtj ඛLb-තLතb්vi mvgMබ් Zඹඹ Kඹq mshඹඹ nඹඹQ
 weifbæDcKiy th_තjv mඹúඹK°20-30 ermi cඹeඹ aviYv Kiv thZ bඹ| gvඹ KඹqK
 ermi cඹeඹ cඹv_ඹK ඛQj Ab_ඹZg cඹඹb ඛඹv DcKiy Ges Gi mඹ_ e_üZ nZ PK-
 තෙW, tcv÷vi ev තKvb ඛQjy gඹWj / bgඹv| GQvov තKvb තKvb තඹඹඹ e_üZ nZ
 I fඹතW cඹR±i, Pj ඹඹ (ඹ_ඹ I Pj gvb), ඹdj ේ ÷ඹBc, ඹඹඹ ev ඹඹf තඹඹg|
 eZඹvb Kවතj ඛඹඹKි bඹMවතj i gඹa` ඹඹඹQ Avi I AtbK ඹඹඹ ඛLb mvgMබ්| තබix
 Gඹඹ sඹb Ges ඹdj ඹBm (Henry Elington and Phil Race, 1985) AvඹKකවතj e_üZ
 G mKj ඛLb mvgMබ්K cඹඹඹMZ Rඹඹ Zvi w K t_ඹK mඹZඹ fඹඹ fඹM KතිතQb hv
 ඹbgඹ: :

**AvඹK ඛLb mvgMබ්
cඹඹඹ**

- gඹZ DcKiy I cඹZඹඹ ඹC (Printed and duplicated materials)
- AcඹඹC cඹ kඹ mvgMබ් (Non-projected display materials)
- ඹ_ඹ cඹඹC cඹ kඹ mvgMබ් (Still projected display materials)
- kඹY DcKiy (Audio materials)
- kඹYmshඹ ඹ_ඹ `kඹ DcKiy (Linked audio and still visual materials)
- `kඹ DcKiy (Video materials)
- KඹúDඹඹ ඹඹĒK DcKiy (Computer mediated materials)

weifbæcඹvi ඛLb-තLතb් mvgMබ් Aඹඹ`_iáZcඹaib_තjv cieZx°cඹvq QඹK
 Dඹඹ Kiv nj |

QK 6.1-1 : ɤkLb-tkLʔbv mɔgMɤ cʔviʔf

**ɤvɤbɔaiʔbi ɤkLb-
tkLʔbv mɔgMɤ**

ɤkLb mɔgMɤ	aib
1/ gɤʔZ DcKiY I cʔZij ɤc	<ul style="list-style-type: none"> • cɤʔcɤK • nʔU AvDU • GʔmɤBbʔgU kvU • eʔwʔɤbʔfʔ ʔɤkLb ɤkʔv DcKiY (gWʔj) • wi ʔmɤmʔDcKiY
2/ AcʔʔɤcZ cʔkʔ DcKiY	<ul style="list-style-type: none"> • PKʔevWʔcʔ kʔ • gvKʔʔ evWʔcʔ kʔ • tdʔevWʔcʔ kʔ • uK Ges j ʔʔevWʔcʔ kʔ • ɤdɛ PɤUʔcʔ kʔ • PɤUʔcʔ kʔ • tɤv ÷ vi cʔ kʔ • Avʔj vKɤPʔ cʔ kʔ • gʔWj cʔ kʔ • cʔKZ.eʔ cʔ kʔ
3/ wʔi cʔʔɤcZ cʔkʔ DcKiY	<ul style="list-style-type: none"> • uɤBW • ɤdj ʔ ÷ ʔBc • gvBʔmɤvdgʔ. gvBʔmɤ ɤdj ʔ, gvBʔmɤ KvWʔ
4/ kʔY DcKiY	<ul style="list-style-type: none"> • teZvi mʔuʔvi • AvWI wʔc • AvWI tUBC (Tape)
5/ kʔYmshʔ wʔi ʔkʔ DcKiY	<ul style="list-style-type: none"> • tUBC uɤBW tɤMʔg • tUBC dʔUvMʔd tɤMʔg • kʔmn ɤdj ʔ ÷ ʔBc • ti wʔi ʔkʔ tɤMʔg • tUBC ɤel qeʔ • tUBC gʔWj, tUBC cʔKZ.eʔ cʔfɤZ.
6/ ʔkʔ DcKiY	<ul style="list-style-type: none"> • tUij wʔkb mʔuʔvi • tUBC ɤdj ʔ tɤMʔg • wʔwʔi tUBC ti KvWʔ • wʔwʔi wʔc ti KvWʔ

იკლბ მვგმბ	aib
7/ კიუდუივიფიეკ დკიყ	<ul style="list-style-type: none"> • WvUv c@mms c`v`KR • WvUv teBm mt ÷ g • Substitute tutor packages • Substitute laboratory packages • Computer managed learning system • Interactive video systems • Multimedia interactive systems

Ictii Qtk eZgvb mgdq wekji wefbet`tk e`euZ Avank იკლბ მვგმბი aib m`utK`Dij L Kiv ntqtQ| Zte me იკლბ cwi`etk G,tjv mgfvt e`envivc`thvMx bq| A_` იკლბ cwi`tek tft` G,tjvi Dc`thvMZv wefbieKg| thgb- G,tjvi tKvbU (ti`Ml, tUvj wfkb, Pj`rPT) MY იკლბი (mass instruction) t`q`T AnaKzi Dc`thvMx| tKvbU e`ir`bfp` `იკლბი Rb` tenk KvhRix, Avevi tKvbU `jMZ იკლბ AnaKzi c`qvM`thvM`| GQov იკლბი vb c`lqv wefbzvi wfi`EtZi wefbreaitbi იკლბ მვგმბ e`euZ ntq `vtK| Zte იკლბ მვგმბ,tjv th t`q`TB e`euZ triv bv tKb `iaZc`velqu nj m`w` იკლბ D`ik` AR`bi j`q` Dch` I h_vh_ იკლბ- tKlvbv mvgM` bePb| Zvici thU weP` Zv nj `YMZ gvbm`ub`იკლბ მვგმბ c`qb| KZ,tjv velq wePbvi gva`tg Dch` იკლბ- tKlvbv mvgM` bePb Kiv thtZ citi | weP` velq,tjv nj -

იკლბ- tKlvbv mvgM` bePb weP` velq

- იკლბი uba`i Z j`q` AR`bi Rb` tKvb aitbi იკლბ მვგმბ Dc`thvMx ?
- tKvb aitbi იკლბ მვგმბ იკლბ_` i Rb` mnRj f` ?
- tKvb იკლბ მვგმბ იკლბ_` i Rb` e`envi Kiv m`earRbK ?
- tKvb aitbi იკლბ მვგმბ იკლბ_` i gta` t`Yv m`otZ mnvqK ?
- იკლბი c`Zovb tKvb aitbi იკლბ მვგმბ mieivn / msM` Ki`Z cvi`te ?
- იკლბ tKvb aitbi იკლბ მვგმბ e`envi Af`` ?
- tKvb aitbi იკლბ მვგმბ e`envi i `q`Zv იკლბ_` i itqtQ ?
- იკლბ_` tKvb aitbi იკლბ მვგმბი e`q ube`n Ki`Z m`qg ?
- tKvb aitbi იკლბ მვგმბ c`vb იკლბ DcKi`Yi KvhRivi ZvtK tRvi`vi Ki`Z citi?

Dcivij- uLZ ubY`qtKi wfi`EtZ Dch` იკლბ მვგმბ bePbci ci th velquI I ci `iaZy`ivc Kiv D`PZ Zv nj `YMZ gvbm`ub`იკლბ მვგმბ c`qb A_`ev იკლბ მვგმბი `Yi gvb ubq`y ev ubi`ZKiY| G BDub`Ui cieZx`cW `q`Z Avgiv იკლბ მვგმბი `YMZgvb ubq`y wefbre`K m`utK`AeinZ ne| Zte G`q`T Dij- L`thvM` th, Avank wek` weAvb I chv`MZ Afivebxq Dbz`i dij wefbreaitbi Avank იკლბ

DcKiY Z_v ukLb-tkLvfbv mvgMŌ D^mweZ ntjI wekji mKj t`tkB GLb chŠf
civ`cyK ev gŷZ ukŷv DcKiYB cāvb ukŷv DcKiY wntmte e`eüZ ntq AvmtQ|
wekI Kti th mKj Dbqbkxj t`tk civ`thvM` AvZwi³ eBcyK cŌqvRbgZ civl qv
hvq bv Ges thLvfb weAvb I chŷ²MZ Dbqfbi mKj mŷj mKtji t`voŷMvovq
tcŷvqvub tm me t`tk civ`cyK Ki , iaz; Avil teuk| GŌvov ukLfb AvMŌ mŷŷZ Ges
civvfvim MVfb civ`cyK Ki weKí ukQyfbB| Avi ZvB cieZr^cciv, tjiZ Dc`mCZ
ukLb mvgMŌi , YMZgvb ubqšŷ m=úukZ Avtj vPbv cāvbZ civ`cyK Z_v gŷZ ukLb
mvgMŌtKB wNti AvenZ² ntqfQ|



civ`Vei gj`vqb 6.1

A) msvŷB Dēi cŷæ

1. Instruction ej tZ Kx eŷvq ?
2. ukLfb i gva`g Kx Kx ?
3. wdj I tiBm Dti - wLZ AvaybKKvtj e`eüZ ukLb-tkLvfbv mvgMŌ, tji v Kx ?
4. eZŷvbKvtj e`eüZ KivúDvivi wfvŷEK ukLb mvgMŌ, tji v Dti t Ki ab|
5. Dchŷ ukLb-tkLvfbv mvgMŌ ubeŷfbi tŷtŷ weŷeP` weI q, tji v Kx ?

Av) iPbvji-K cŷæ

1. AvaybKKvtj e`eüZ ukLb-tkLvfbv mvgMŌi tkYwefvM Ges wevfbaib Dti t Ki ab|

Arcb MuztZ Ges th tKvb Kg^cmi tetk cotZ citi | GRb` tkYxKtŷi AvbŷmbK
cwi tek ev mgtqi tKvb aiverav ubqg Abyri Y Kivi cŷqvrBb nq bv | eisj it`k Dbŷŷ
wekte`ij q cwi Pwŷj Z wefbank ŷŷv tŷŷMŷtgi ŷkLb mvgMŷ GB` ŷkLb c^xwZtZ i wPZ |

ŷkLb mvgMŷi , YMZgvb ubqŷŷYi cŷqvrBbqZv

**YMZgvb^mubakLb
mvgMŷ ŷkŷŷŷŷ
ev`ŷvqtbi ceRZ^c**

ŷkLb mvgMŷi, mij ev`ŷkLb th tKvb cKwZiB tnvK bv tKb, YMZgvb ubqŷŷY
GKwU AZxe , iazcY^qel q | th tKvb ŷkŷŷŷŷ Kvhŷŷtgi ŷkŷŷŷŷtgi gvb hZ DbzB tnvK
bv tKb, ŷkLb mvgMŷi , YMZgvb ubwŷZKiŷYi Dci H ŷkŷŷŷŷtgi cZ`wKZ Ges
dj cŷh-ev`ŷvqb wbfŷKxj | e`Z , YMZgvb^mubakLbmvgMŷ th tKvb ŷkŷŷŷŷ Z_v
ŷkŷŷŷŷi KvhRix ev`ŷvqtbi ceRZ^ctjvi Ab`Zg | ŷkLb mvgMŷi cZ`wKZ gvb eRvq
ivLv m^e bv ntj Zv ŷkŷŷŷŷ^xŷ msŷk- ŷt`i gta` cŷqvrBbq Avte`b mwŷtZ e`ŷq hv
cKvŷŷŷŷi ŷkŷŷŷŷi j ŷŷ` I Dŷŷk` ARŷŷK e`vnZ Kŷi | dtj ŷkŷŷŷŷi gva`tg ŷkŷŷŷŷ^x
AvPiŷŷYi cZ`wKZ cwi eZ^ŷ Avbqb m^e nq bv Ges cŷjv ŷkŷŷŷŷ e`e`vi , YMZgvtbi
I ci-Gi tŷwZevPK cŷŷve cto | AZGe, th tKvb ŷkŷŷŷŷ Kvhŷŷtgb ŷkLb mvgMŷi
, YMZgvb h_vh_ , iŷZŷi mwŷt_ ubqŷŷY I ubwŷZ Kiv cŷqvrBb |

ŷkLb mvgMŷi , YMZ gvb ubqŷŷYi Dciw

civ`cŷK ev gŷZ ŷkLb mvgMŷi , YMZgvb mwavi Yfvte wbfŷ Kŷi welqe`i Mfxi Zv,
wbfŷZv, Dc`vcb c^xwZ, KvwŷŷŷŷMZ w`K, gŷY, web`vm, gj`vqb c^xwZ BZ`w` wefŷbe
w`ŷKi hŷŷmsMZ, be^ŷK I gŷbweAvbm^sZ Dc`vcŷbi Dci | Gme w`K ubwŷZ
KiŷZ ntj cŷqvrBb`ŷŷ w`ŷKi - (1) ŷkLb mvgMŷ cŷŷŷŷbi GKwU h_vh_ Kg^ewi Kŷi bv
Ges (2) ŷkLb mvgMŷi h_vh_ cŷŷŷŷ c^xwZ |

(1) ŷkLb mvgMŷi cŷŷŷŷbi Kg^ewi Kŷi bv

ŷkLb mvgMŷi , YMZgvb ubwŷZ KiŷZ ntj cŷŷŷŷ cŷqvrBb Dchŷ Kg^cwi Kŷi bv
cŷŷŷŷ hvi wfi^etZ cieZx^ŷ ŷkLb mvgMŷi cŷŷŷŷbi mvgMŷK KgRvU m^ubaKiŷZ nte |
e`Z th tKvb Kŷŷŷŷi mŷzm^uv`b eŷj vŷŷk wbfŷ Kŷi Dchŷ Kg^ewi Kŷi bv cŷŷŷŷbi
I ci | Kxŷŷŷŷ Ges Kx Kx arc Abyri Y Kŷi ŷkLb mvgMŷi cŷŷŷŷ nte Zv cŷeB cwi Kŷi bv
Kŷi wŷtZ nte | civ`cŷK ev ŷkLb mvgMŷi cŷŷŷŷ Kg^cwi Kŷi bvi GmKj avc wefŷbe
t`ŷk wefŷbei Kg nŷZ citi | Zte th tKvb ŷkLb mvgMŷi , YMZgvb ubqŷŷY KiŷZ ntj
Gi Kg^cwi Kŷi bvq wŷtge^s avc , tj v Abyri Z nI qv evAvbxq |

**ŷkLb mvgMŷi cŷŷŷŷ
Kg^ewi Kŷi bvi**

1. **Dŷŷk` ubaŷŷY:** Kx mwŷŷŷŷ ŷ Dŷŷk` ARŷŷi Rb` ŷkLb mvgMŷi cŷŷŷŷ KiŷZ nte Zv
cŷeB ubaŷŷ Y KiŷZ nte |
2. **welqe` ubaŷŷY:** ubaŷŷi Z Dŷŷk` ARŷŷi j ŷŷŷŷ ŷkŷŷŷŷ^xK Kx ŷkLb AwfAZv
t` I qv nte Zv ubaŷŷ YceR Dchŷ welqe` ubaŷŷ Y KiŷZ nte |
3. **wetkIA AwfgZ MŷY:** ŷkLb AwfAZv I welqe` Pqb KZUv thŷŷŷŷ K I
gŷbweAvbm^sZ nŷtqQ Zv hvPvB Kivi Rb` wetkIA t` i AwfgZ MŷY KiŷZ nte |
4. **Lmov civŷŷŷŷ cŷŷŷŷ:** ŷkLb mvgMŷi cŷŷŷŷbi wefŷbeMŷŷŷŷŷŷŷŷ I Dchŷ c^xwZ
Ges arc Abyri Y Kŷi Lmov civŷŷŷŷŷ cŷŷŷŷ KiŷZ nte |

- wegzavi Yvi c0qvrbrq e`vL`v i tqfQ;
- weiqe`m`yúó Ges tKvb `je`Zv ev A`úóZv tbB;
- bZb AvRZ Ávb c0qvM Mi mthvM i tqfQ;
- weiqe`gg`úkrGes wkqv_xp AvM0tK ati ivtL I cvtV D0x Kti;
- weiqe`Dc`vctb chfB wbitcqvZv i tqfQ;
- wkqv_i gtbv%ÁmbK i mZ, thgb- mnR t`tK Kwb, Rvbn t`tK ARvbn, gZ`tK wegz`BZ`w` Abyi tY Ges ths`Kfvte weiqe`Dc`mZ Ges
- wbr mgvR, cwi tek I mvs`wZK bg(norm) I ev`éZvi mvt_ m`úuKZ/

wkLb mvgM0i wkLb wbt`Rbvmspvš, YMZ mPK

**wkLb wbt`Rbvi
YMZ mPK**

- weiqe`wkqv`v`v`bi gj-bmZ I c`wZi wfvÉtZ i vPZ;
- wkLb mnvqK c0qvrbrq AvfÁZv I KvtrI mthvM i tqfQ ;
- wkLb Kvherg AbywKfvte (sequentially) webt`f
- wkqv_xp i gta` D`PZi Ávb mšÚxq `qvZv (higher cognitive skill), thgb- c0Zdij Z vPš (creative thinking), mRbkj Zv, nvtZ Kj tg KvR, Abyúvb I mgm`v mgvaib, `qvZv BZ`w` m0tZ mnvqK ;
- wkqv_xp i gta` Mtel Yrgj-K gtbvve m0 Kti Ges
- wkqv_xp wbtRi wkLb AMwZ gj`vq`bi chfB mthvM i tqfQ/

cvthvM`Zv m`úuKZ , YMZ mPK

**cvthvM`Zv m`úuKZ
YMZ mPK**

- wv`0 tkYx ev chfqi wkqv_xp i cvthvM` ;
 - e`eüZ kã, evK` wv`0 tkYx ev chfqi wkqv_xp i Dc`thvMx ;
 - evK`, Abt0t` i Kvvtgv h_vh_ Ges j`v`tj i KvQ AvKI vYx;
 - e`eüZ bZb kã I cwi fvlvi c0qvrbrq e`vL`vi AšfB;
 - weiqe`i Dc`vcb mnR, mvej xj I AvKI vYx;
 - wkLb wbt`Rbv, Abkxj bx, ckr wkLb Kvherg m`yúó;
 - GK cv t`tK Avti K cvtVi axi, mnR Ges mgvbgwZR DÈi Y ;
 - cvb cvVb Avb` `vqK Ges
 - gy`Yi aib Ges etYp AvKvi h_vh_ I wkqv_xp i cv Dc`thvMx/
- weiqe`i webt`vmmZ , YMZ mPK**

**web'imMZ , YMZ
mPK**

- Aa'vq, Dc-Aa'vq thŠir³ Kfirte web'it
- welqe'i miP, QK, iPT h_vh_firte web'it hr mntR Ges`az LR tei Kiv mae;
- iktivYvg, Dc-iktivYvg welqe'itK h_vh_firte cÖZdjw Z Kti;
- welqe'itZ e'eüz ietkl ktai (term) myúo avi Yv maej Z iBNÉi (glossary) msthrRb;
- h_vh_ Ges chBmsL`K D`vni Y I iPTi e'envi ;
- MÖd, PvU[©]tUvej BZ'w i h_vh_ web'im Ges myúo e'vL'v ;
- , iazcY[©]Z` I kätK iefb[©]firte AvKI Yiq Kiv ;
- cÖZw Aa'vq ev BDibti cÖqvRbxq fvgKv, chBj vPbv I mvi mstjC Ges
- gj- welqe'i , iaz; Abbyqx Aa'vtqi I cvtvi`N[©]

Kivtgv ev MÖdK iWRvBb mspvš , YMZ mPK

**Kivtgvmspvš , YMZ
mPK**

- iKLb mvgMöUi cÖQ` AvKI Yiq ;
- gj- iktivbvg, Aa'vq iktivbvg, Dc-iktivbtgi aib I web'im myi, AvKI Yiq Ges mnRteva;
- cÖv mSL'v, Aqti i gvc, iPT BZ'w iktiv[©] i DcthvMx;
- e'eüz Qie, iPT I D`vni Y, tjv
 - myúo I h_vh_
 - AvKI Yiq
 - Acwi iPZ avi bvi h_vh_ e'vL'v cÖvb Kti
 - iktiv[©] i gta` AvMö myó Kti Ges Drvine'vÄK
 - welqe'i Pwin`vbyqx h_vh_`itb Dc`mcZ Ges
 - iPTi iktivbvg myúo I h_vh_|

GZqY Avcbv i KLb mvgMö Z_v cv'cyK i , YMZgvbtbi iefb[©]cKvi mPK m'úK[©] AeinZ ntqQb| cv'cyK i , YMZgvb i bÖZ KiZ ntj welqe'; iKLb i b[©]Rbv, cv'thvM'Zv, web'im, Kivtgv BZ'w i K, tjvi , YMZ mPti cÖZ`wó ti tL Zv cÖqb KiZ nte| Avi GB mPK, tjvi cÖZdj b hZ tewk mae nte , YMZ gvbm'úbe cv'cyK cÖqbtbi m'ebv ZZ ewx cite| GQrov cv'cyK ev iKLbmvgMö cÖxZ I e'eüz nl qvi cti l mgq mgq D'tj mZ , YMZ mPK, tjvi i fivÉtZ G, tjv gj'vqZ nl qv DiPZ| gj'vqtb cÖB i dWe'vK-Gi Avtj vtK cv'cyK, tjvi cwi gvR[©] , YMZgvb i bÖZKi tYi Rb` Acwi nvh[©]



ciVvEi gj`iqb 6.2

A) msuŋB DEi cŋæ

1. iPbvi ixiZi wfiEŋZ gny`Z ukLb mvgMŋK KqfiŋM fVM Kiv hvq I Kx Kx?
2. `^ukLb ixiZŋZ iŋPZ ukLb mvgMŋi `ewkó` Dŋj L Kiab|
3. ukLb mvgMŋi , YMZgvb ubqšŋYi cŋqvRbxqZv Kx?
4. ciV`cyŋKi melqe`i , YMZgvb ubqšŋYi mPK , ŋj v Kx?
5. mweRfiŋe ukLb mvgMŋi gvb ubqšŋY KiŋZ nŋj tKvb tKvb wŋŋKi , YMZgvb ubqšŋYi cŋqvRb iŋŋŋQ?
6. ukLb mvgMŋi ciVŋhV`Zv m`úukŋŋ , YMZ mPK , ŋj v Dŋj L Kiab|

Av) iPbvj-K cŋæ

1. ukLb mvgMŋi , YMZgvb ubqšŋY GKŋU Dchŋ Kgeŋi Kí bvi , iæZjDŋj LceR Gi avc , ŋj v eYŋv Kiab|
2. ukLb mvgMŋi mweR gvb ubqšŋYi jŋŋ` newfbæaiŋbi , YMZ mPK , ŋj v Dŋj L Kiab|
3. ukLb mvgMŋi cŋŋqŋb , YMZ newfbæw`K , ŋj v ubqšŋZ bv nŋj Kx Amŋeav nŋZ ciŋi tm m`úŋK`Avcbvi gZvgZ mŋŋŋŋc eYŋv Kiab|
4. (K) th tKvb tkŋxi GKŋU ciV`cyŋK newfbæ , YMZ mPŋKi Avŋj vŋK gj`iqb Kiab Ges cŋB mŋgve`Zv , ŋj v Dŋj L Kiab|
 (L) gj`iqŋb cŋB wdWe`vK-Gi wfiEŋZ ciV`cyŋKŋU , YMZ gŋŋbubqŋŋbi Rb` KŋqKŋU mŋvni k ij Lŋ|

th tKvb mgq cvV Kiv hvq (Available at any time)	e`w ³ i wBR`mgq, mshvM Abhvqx th tKvb mgq cvV Kiv hvq
th tKvb vtb cov Pwj tq hvI qv hvq (Available at any place)	wkqv_x ^o emoZ ev Kg ^q it` ev agY th tKvb RvqMvq G, tjv covi Rb` mvt_ ivL ^t Z ev wbtZ cvtib
th tKvb msL`K wkqv_x ^q K wkqv tcvM ^o tg fivZ ^p mshvM cVvb Kiv m ^a e (Available to any number)	GKmv ^t _ KZRb wkqv_x ^o wLb wkqv DcKiY co ^t e Zv ce ^o ba ^o i Z bq, hv MZvbMvZK wkqv ^q mxgve ^x dtj GKB mv ^t _ AtbK wkqv_x ^o G, tjv co ^t Z cvti
Av`k ^o qZ w ^e lq ^e - (Standardized content)	mKj wkqv_x ^o GKB wkqv DcKiY e`envi Kti_ v ^t K dtj mKtj GKB w ^e lq ^e -` cv ^t Vi gva`tg GKB gv ^t bi AvfAZv m ^A q Ki ^t Z mg_`nq
w ^e tklA KZR ^o cVvZ w ^e lq ^e - (Expert prepared content)	RvZiq Ges AvSR ^o ZK ch ^q qi w ^e tklA ^e ,` w ^e lq ^e -` iPvvi t ^q it` Ae`vb ivL ^t Z cvtib, dtj w ^e lq ^e -` nq gvbm ^a Z
bevqb ^t h ^v M w ^e lq ^e - (Updateable content)	G ai ^t bi wLb mvqM ^o mvaviYZ c`v ^t KR DcKiY nI qvq mn ^t R `z ^z bevqb Kiv m ^a e nq
Kiv ^t gve ^x wkqv (Structured teaching)	wkqv c ^x vZ m ^o vw ^o v ^t ve Kiv ^t gve ^x Ges Avbv ^o gK (sequenced) thgb, cV ^o tg wkqv_x ^o ce ^o avi Yv hvPvB Kiv nq gv ^t S gv ^t S fvqKv I w ^t Rbv_ v ^t K mevKQy wgvj ^o tg GKw Kiv ^t gve ^x i ^o vZ ^t Z G ^t Z w ^e lq ^e -` AvqE ^o Ki ^t Yi e`e`v i ^t q ^t Q
m ^o uq wLb (Active learning)	Dc`w ^o Z w ^e lq ^e -` wL ^t bi gva`tg AvZ ^t -` Kiv nq etj wkqv_x ^o m ^o uq fvqKv cvj ^t bi mshvM_ v ^t K
tcSb:tcSbK djveZ ^o (Frequent feedback)	wkqv_x ^o i cv AM ^o vZ Rvvi Rb` tcSb:tcSbK gj`vq ^t bi mshvM i ^t q ^t Q dtj wkqv_x ^o w ^t Ri AM ^o vZ NbNb gj`vq ^t bi gva`tg Gi Dbq ^t bi mshvM cvq
m ^o vw ^o v ^t ve I D ^t ik` (Explicit aims and objectives)	G ai ^t bi wkqv DcKiY cv ^t Vi gva`tg wkqv_x ^o Kx j ^o I D ^t ik` AR ^o Kite Zv cVZw cv ^t Vi i ^o ia ^o Z m ^o vw ^o v ^t ve w ^e eZ_ v ^t K
e`w ³ w ^o f ^o w ^o D ^t Uvvi s (Individualized tutoring)	w ^o D ^o u MZvbMvZK c ^x vZ ^t Z mKj ^t K GKmv ^t _ w ^e lq ^e -` cvV bv w ^o tg wkqv_x ^o K e`w ³ MZ P ^o vw ^o vi w ^o v ^o E ^t Z c ^o qvRbxq mnvqZv w ^o tg_ v ^t Kb

wLb wkqv DcKi^tYi , YMZgv^tbi mPKmg^a

I c^tii 6.3-1 Q^tK wLb wkqv DcKi^tYi m^ovw^o v^tve `enk^o, tjv m^au^tK^oAvcbvii AevnZ n^tq^tQb | wLb wkqv DcKiY c^ovq^tbi t^qit` G mKj `enk^o i h_vh_ cVZdj b-Gi mv^t_ , YMZgv^tbi Nib^o m^au^tK^oi^tq^tQ | w^tP wLb wkqv DcKi^tYi , YMZgv^t w^oq^o I hvPvB^oqi mPKmg^a A^tc^ovKZ. w^e-Z. cv^o m^ti Dc`w^oZ nj | wLb wkqv DcKiY c^ovq^tbi G mKj m^oP^tKi cVZ m^tPZb `w^o ube^x Kiv n^tj Gi , YMZgv^t ev^x cv^ove I Zv w^ov^oZ Kiv m^ae n^te etj cV`vkv Kiv hvq |

Dfík

DfíkMZ , YMZmPK

- cḡqvRbxq ceAvb I ḡZvi mḡbw ḡ wbt`Rbv vKtZ nte;
- Dfík mḡúofite Ges tKvbi Kg A`úoZv Qvov (AvPi wYK fvlvq) weeZ vKte;
- Dfík , tjv mnRfite I eÜmjyF cḡuqvq Dc`mncZ nte Ges
- Dfík wj Ltḡ Acwi wPZ cwi fwi K ktāi e`envi cwi nvi Ki tZ nte|

KvWtgv I web`vm

KvWtgv I web`vmMZ , YMZmPK

- ḡKlb wKḡv DcKi tYi mḡbw ḡ KvWtgv Abyi Y Kti i Pbv Ki tZ nte ;
- wKḡv DcKi Y `k`Z I e`envi K Dfq `wotKiv t`tK AvKI ḡvq nte ;
- wKḡv xḡ i cḡqvRbxq tḡvU tḡlqv, cḡkie DEi tj Lv Ges wmwie I MYvi Rb` tj Lvi cvtk chḡB dḡKv RvqMvi e`e`v vKte Ges
- wKḡv xḡ cḡqvRbv wḡv tḡi Dc`mncZ wclqe`i ceZb avi Yv wKsev cieZx`avi Yvq hv l qvi mnR wbt`Rbv vKte|

ḡj`vqḡbi Rb` cḡwvj I Kihḡvj

- ḡj`vqḡbi Rb` chḡB mSL`K cḡw activity ev Kv tRi e`e`v vKte ;
- ḡj`vqḡbi Rb` Dc`mncZ cḡwGes KvRmgḡ mḡúo Ges mḡ`ngḡ nte ;
- cḡwGes KvR , tjv wKḡv xḡ i wBKU AvKI ḡvq nte;
- wKḡv xḡ i Rb` cḡkie DEi tj Lvi chḡB RvqMv vKte Ges
- wKḡv xḡv cvtVi wbaḡi Z Dfík mgḡ ARḡ Ki tZ tctitḡ wK bv Zvi cwi gvtci Rb` cḡE cḡwGes KvRmgḡ chḡB, h_vh_ I mnvqK nte|

fvgKv, mvi mstḡc Ges chḡj vPbv

- cḡZwU cvV Avb` `vqK Ges DḡxKi Ygj-K Dcvtq Dc`mncZ nte;
- fvgKvsk wKḡv xḡ i cvtVi web`vm I wclqe` m`m`útk`cḡ wḡK avi Yv w`te;
- cvtVi tktl wclqe`i mvi mstḡc ev chḡj vPbvi e`e`v vKte Ges
- wKḡv DcKi YwU mn tR cḡcḡv Kiv hvq Ggbfite wj wLZ nte|

wclqe`

- wclqe` mnR cvbthvM` Ges A`úoZvḡ nte;
- wclqe` Dfík tK cḡZdij Z Ki te A`ḡ cḡmwzK nte Ges
- wclqe`i cḡqvRbxq Astk wKḡv xḡGes tj LKt`i cḡqvRbxq K_v Dfj - L Ki tZ nte| A`ḡ wclqe`i meḡ wKḡv xḡK Dfík Kti ḡAvcubḡ kāwU, tj LKtK (wḡwḡ gj-Z wclq wKḡtKi fvgKwfbq Ki tQb) eḡv tZ ḡAvḡḡ kāwU Ges wKḡv xḡI tj LK Dfq tK eḡv tZ ḡAvḡi vḡ kāwU e`eüZ nte|

Wwqumŋ, PuU, mvi Yx BZ w

- hZUv mɘ ṯeṯVṯwqZ nte;
- cŋiwi miṯ cŋqRbrq ɯbṯ Rbv ev ɯktivbvg Dŋi ɯKte Ges
- cŋqRbrq msLṯK Qwe I RrebaxDṯvniY ɯKte|

mvavi Y w K

- BDubU, ciV BZ w i cwimi h_vh_ nte A_ ɴ 45 ɯgubtuI GKU GKvKx tmktb cori Dchɿ Astk (manageable chunk) ɯF³ nte|
- GKU ciV ev ciVṯsk t_ŋk Abṯ ciV ev ciVṯŋki mnR DĒiY (smooth transaction) nte A_ ɴ tKvb GKvKx ɯkŋi_vxṯhb KLtbv_gŋk thŋZ evaṯ bv nb ev Sɿk Abŋe bv Ktib;
- tgav mɘbɘ:ɯkŋi_vxṯ hṯZ Kti Dŋi k AR⁹ KiŋZ cṯi tmwŋk j ŋ tiŋL ṯkLb ɯkŋi_v DcKiŋYi ɯelqe ṯi vPZ nte Ges
- Mo tgavi ɯkŋi_vxṯ i ɯbKU DcKiY ɯU mnRŋevaṯ I Avbṯ vqK nte|

eZgvb cṯiV Avgiv ṯkLb ɯkŋi_v DcKiŋYi mɘbɘ⁹ ṯeṯwóṯmgn mɘuṯK⁹AeinZ nj vg| tmB miṯ_ G aiṯbi ɯkŋi_v DcKiY cṯqṯbi tŋiŋtṯ ṯYZgvb ɯbqŋY I ep^x KiŋZ nŋj tKvb ɯ^k_tjvŋZ tLqj ivLv cŋqRb tm mɘuṯK⁹ ɯKQyRvbj vg| ṯkLb ɯkŋi_v DcKiŋYi tŋiŋtṯ ṯYZgvb GKU AZṯš^l iṯZcY⁹ ɯelq| G aiṯbi ɯkŋi_v DcKiY thŋZ mɘúY⁹ ɴc e^ṯ³ ɯbf⁹ (individualized) tmŋZzGi ṯYZgvb ɯb⁹Z KiŋZ bv cṯiŋ Zv ɯkŋi_vxṯ i gtaṯ cŋṯkZ Avteṯ b mɘŋŋZ e^ṯṯntZ cṯi| dj k⁹ZŋZ G aiṯbi ɯkŋi_v DcKiY cṯqṯbi Dŋi k AR⁹ nte eṯvZ| AZGe ṯkLb ɯkŋi_v DcKiY cṯqṯbi tŋiŋtṯ ṯYZ gvṯbi ɯbaŋK ev mPK⁹ tji h_v_ṯc⁹ ŋZdj b ni qv evAṯbxq|



ciVvEi gj"vqb 6.3

A) msvfB DEi ckae

1. ᄃkLb ᄃkᄃv DcKiY Kx?
2. ᄃkLb ᄃkᄃv DcKiᄃYi Dᄃk" Kx aiᄃbi nI qv DvPZ?
3. ᄃkLb ᄃkᄃv DcKiᄃYi nelqe"i ᄃYMZ mPKᄃtjv Dᄃk L Kiab|
4. ᄃkLb ᄃkᄃv DcKiᄃYi ciV-Gi cwi mi Kx aiᄃbi nI qv DvPZ?
5. ᄃkLb ᄃkᄃv DcKiᄃYi ᄃYMZgib ᄃbᄃZ Kivi cᄃqvRbxqZv e"vL"v Kiab|

Av) iPbvj-K ckae

1. ᄃkLb ᄃkᄃv DcKiᄃYi ᄃenkó" vj Lᄃ|
2. ᄃkLb ᄃkᄃv DcKiᄃYi ᄃYMZgib mPKᄃtjv Dᄃk L Kiab|

mVK DEi :

A) 1| K; 2| L;



Povſhgj`iqb- 6

A) mſmſB DĚi cĕæ

1. Instruction ej ſZ Kx eſvq?
2. űkLb-tkLvſbv mvgMŰ KvſK etj ?
3. Dchŷ űkLb-tkLvſbv mvgMŰ űbeſſſb űeteP" űel q, tj v Kx?
4. mij iſZi űkLb mvgMŰi `eiſkŰ" Dſj L Ki ab|
5. űkLb mvgMŰ cſſqb KgŰwi Kí bvi avc, tj v Kx?
6. űkLb mvgMŰi űkLb űbſ`Rbvmsſvſſ, YMZ mPK, tj v eYŰv Ki ab|
7. űkLb mvgMŰi, YMZgvb űbűŰZKiſY ſKvb űel q, tj vi cſZ bRi ſ`l qv cŰqvRb?
8. `űkLb űkſſv DcKiY Kx?
9. `űkLb űkſſv DcKiſYi KvſſſvMZ űeb`vm Kx aiſbi n l qv DſPZ?
10. `űkLb űkſſv DcKiY cſſqſb űeteP" mvari Y ű`K, tj v Kx?

Av) iPbvſj-K cĕæ

1. űkLb mvgMŰi AvſbK ſkYſſeſſM Avſj vPbv Ki ab|
2. űkLb mvgMŰi mſſeſſ gvb űbqſſſYi, YMZ mPK, tj v Avſj vPbv Ki ab|
3. űkLb mvgMŰ cſſqſb, YMZ ű`K űbqvſſZ bv nſj Kx Amſſeav nſZ cvſi ſm mſſſſK[©] Avcbvi AvſſgZ mſſſſc eYŰv Ki ab|
4. `űkLb űkſſv DcKiſYi, YMZgvſbi mPK, tj v eYŰv Ki ab|

„YMZgub ubwöZKiþY tckvMZ tbZZj.

[Professional Leadership for Quality Assurance]

fjgKv

uk¶vi mmeK gvb Dbqþbi jþ¶¶ weþkþi Dbqþkxj t`kmgñ ubiþfi cþPöv Pwþj tþ hvþ¶Q| ukŠ' Zv mþEj| `k`Z uk¶vi gvb w`b w`b ubgþvþx nt¶Q| uk¶vi „YMZ gvb ubaþvþZvi Ab`Zg cþvb KviY wntmte uk¶we`MY tckvMZ tbZþZj AfveþK wþwýZ KþiþQb| eZgþv BDibþU uk¶vi „YMZgub ubwöZKiþYi jþ¶¶ tbZþZj cþPvb I AvapþK aviYv, weþfþeaiþbi tbZZj; iþwZ, tckvMZ tbZþZj weKvk I Dbqþ Ges tbZþZj „Yveþj mþúþKweþfþeavþVi gva`tg Avþj vKcvZ Kiv ntþtQ|

Avþj vPbvi mþeavþ`G BDibþU mgMö weþqþK cþPw cþþVi gva`tg Dc`vcb Kiv ntþtQ| wþtgacþZ`Kw cþþVi ukþivþvþg Dþj þ Kiv nj |

- cW 7.1 t tbZZj: cþPvb I AvapþK aviYv, msÁv I „iaþj**
- cW 7.2 t weþfþeavþbZZj; iþwZ**
- cW 7.3 t tckvMZ tbZþZj weKvk I Dbqþ cþþvþv**
- cW 7.4 t uk¶vi „YMZ e`e`vcbvþ tckvMZ tbZþZj weþfþeavþ K**
- cW 7.5 t tbZvi „Yveþj**

cW 7.1

tbZZj: cPxb I AvapbK avi Yv, msAv I , iaZj

[Leadership : Old and Modern concepts, Definition and Importance]

Dfik`

GB cW tk`I Avicib –

- tbZtZj avi Yv meeZ KitZ cvi`teb;
- tbZtZj cPxb I AvapbK avi Yv eY`v KitZ cvi`teb;
- tbZtZj KtqKuU msAv ej tZ cvi`teb Ges
- tbZtZj , iaZj eY`v KitZ cvi`teb|

ik`v Kvh`ug cwi Pvj bvi Rb` tckvMZ tbZtZj fvgKv AZ`š , iaZcy` tckvMZ
 tbZZj.Kg`m`uv`tb ewj o fvgKv cij b Kti | tbZtZj gva`tg mnKgx` i msNex Kti
 Kvh`m`uv`tbi Abkj` cvi`tek mjo Kiv hvq weavq j`v` AR` mnRZi nq| ik`v
 Kvh`t`g c`xY, `v, AvfA` ik`vK I KgRZMY Z`i Dci AvcZ``vqZj Ges KZ`
 m`uv`tb Aaxb` KgRZP I KgPvix` j`K tckvMZ tbZZj.c`v`tbi gva`tg Afxó j`v`
 AR` ubw`ZKi`Y mivK ubt`Rbv c`vb KitZ cvi`b|

tbZtZj avi Yv

tbZZj`c`uI AvrfambK A`vj cwi Pvj bv ev c_ c`k` Kiv| tbZZj.GKuU gbbkxj
 avi Yv| Gi gj- K_v nj AcitK c`vmeZ Kivi Rb` tKskj e`envtii`v`Zv| tbZZj;
 tKej D`P ct` Avmxb KgRZ`i gta` mvgvex bq| tKvb netkl j`v` AR`bi Rb`
 hLbB tKvb GK e`v` AcitK c`vmeZ Kti Dwi`o KvRiU m`uv`b KitZ mg`nb
 ZLbB Avgiv ewj H e`v`i tbZZj.`v`tbi `v`Zv itqtQ|

tbZtZj mbvZb I AvapbK avi Yv

tbZZj.GKuU RiUj I e`uglx c`uqv| tbZZj.m`utK`Avtj vPbv KitZ hvl qvi AvtM
 Avgv`i`K ubt`Pi c`kaKquI DEi L`tZ nte| Zv ntj B Avgiv tbZtZj GKuU cY`%
 avi Yv cre|

- tbZZj.ej tZ cKZct`v` Kx tevSvq ?
- tbZZj.I Avyri Y Kx mnRvZ ?
- tbZv`i Kx KZ , tj v mjbv`v` , Y_v`K ?
- tbZZj.Kx Abkj` cvi`te`kiB dj ?

Dctiv`3 c`g`tjvi Reve tctZ ntj Avgv`i`K tbZtZj mbvZb I AvapbK avi Yv
 m`utK`RvbtZ nte|

tbZtZj msÁv (Definition of Leadership)

tbZZtK e'e'vcbvi GKUW , iazcYAsk wntmte aiv nq| tbZZj:cwi Pvj bvi GKUW tKŠkj | BstiwRtZ Leader ktāi AwfambK A_°nj c_ cŃkŃ Kiv, Pvj bv Kiv, wbt`R t`qv| e`Z tbZZj:tKvb wbeŃxi wbt`Rbv, c_ cŃkŃ I Ab`vb`f`i KivRi Dci cŃve we`li Kvi x GKUW D`wbebx cŃuqv hv e`w` I msMVtbi gva`tg wbw`Ń j`Ń` ARfb mnvqZv Kti |

MtelKMY tbZtZj wfbewfbemsÁv w`tqtQb| Gmtei cŃvb KtqKiu wbtgqAvtj vPbv Kiv nj :

tbZtZj KtqKiu msÁv

Stogdill (1950) tbZZj:m`fU etj tQb, ŃtbZZj:n`Q j`Ń` wbaŃY I j`Ń` ARfb Df`tk` GKUW msNex Kgx`tj i Kvhewj cŃmeZ Kivi cŃuqv|Ń

Hollander (1978) Gi gŃZ, ŃtbZZj:tbZv Ges Zui AbymYKvi`f`i gŃa` cŃve we`f`i i GKUW cŃuqvŃ|

Koontz and O'Donnell (1984) tbZZtK msÁmqZ Kti etj tQb th, ŃGuV RbMYtK cŃve`S`Z Kivi GKUW tKŠkj ev cŃuqv hvZ RbMY AvMŃ f`i th`_ j`Ń` ARfb Rb` m`PŃ nq|Ń

Rauch and Behling (1984) Gi gŃZ, ŃmsNex `tj i Kvhewj tK j`Ń` ARfb w`tK cŃve`S`Z Kivi cŃuqv`K tbZZj:AvL`mqZ Kiv thtZ cvti |Ń

Aa`vcK tWeb B, gvKdvij`v`Ńi gŃZ, ŃtbZZj:nj Avšte`w`K cŃfetei GKUW cŃuqv hv gva`tg tbZv Df`tk` wbaŃY Ab`vb`f`i Kvhewj tK cŃmeZ Kti |Ń

tebm-Gi gŃZ, ŃtbZZj:n`Q GKUW we`kl cŃuqv hv gva`tg GKRB cŃZwba Zui Aarb`Kgx`M`K Kiv`ŃZ AvPi`Y DŃx` Kti |Ń

tnBg`vb-Gi gŃZ, ŃtbZZj:nj Ggb GKUW cŃuqv hv Ńviv GKRB wbeŃxi tKvb we`kl j`Ń` wbaŃY I ARfb wbtqvwRZ Acivci Kgx` i Kvhewj tK mnRteva`f`ite wbt`Rbv `vb, cwi Pvj bv I cŃmeZ Kti Ges e`w` I msMVtbi gŃa` Ggbfite ga`Zv Kti hvZ Dfqb meŃak mšw` j`vf Kti |Ń

tnbix tK`-`Ń_-Gi gŃZ, ŃtbZZj:ej tZ we`kl j`Ń` ARfb wbwgtE` e`w`tZ e`w`tZ cŃve we`f`i i cŃPŃv`KB tevSvq|Ń

wm AvB evb`V`Gi gŃZ, ŃtbZZj:n`Q e`w` AvPi`Yi , Y hv RbMYtK msNex cŃPŃvq KivR Ki tZ cwi Pvj Z Kti |Ń

tbZZj:welqK mbvZb avi Yv

Gwi ÷ Utj i gZ AvRI A`btK gtb Ktib th, ŃŃKn tKn kvmb Kivi Rb` Ges tKn tKn kvwmZ nI qvi Rb` RbWŃY Kti |Ń tbZZj:m`fU G ai tbi ŃŃkŃ gibeŃ m`u`K`Z avi Yv Ewbk kZtKi cŃ_gŃa`euj cŃvj Z wQj | Zvti i gŃZ tbZZj:nj Rb`m`f` cŃB KZK , tjv we`kl , Yvevj i dj | Gme Rb`m`f`-cŃB , tYi Afve ntj tbZv wntmte mdj nI qv hvq bv|

**mbvZb tbZtZj
`erkó**

tbZtZj mbvZb avi Yv Abjviti tbZv Zui Aaxb`t`i Dci ŶlgZv cŰqvM Ktib| wZwb
wb`R t`b, Aaxb`iv webv cŰZevt` Zv tŷtb tbq Ges tm wb`R Abjviti KvR Kti|
wm×všl MŰY ev Kg©cui Pvj brq Zui i tKvb AwKvi _vtK bv| tKvb cŰZŵtbi cŰvb
Aaxb`t`i Dci ŶlgZv cŰqvM I wb`R w`tq Kg©m=úv`b Kitz cvi tJ B wZwb tbZv|
A_ſ mbvZb avi Yv Abjviti tKvb cŰZŵtbi cŰvb GKRB tbZv|

GB Dc-gnvt`tk eŷJk Avgtj Ges cŷK`lv Avgtj i cŰg w`tK wkŶv wefvMi tbZZj;
wQj tK`tfZ| wkŶv wefvMi cŰvbi wb`R Abjviti B wm×všl MŰY I Kg©m=úv`b Kiv
nZ| G aitbi tbZZj; mbvZb tbZtZj avi Yv| Avkvi K_v GB th, mgtqi mvt_ Zvj
wgij tŷ Pjvi Rb` Ges nekŷqŷbi hŷM wbR`^`vb Kti tbi qvi Rb` axti axti G
gubwKZvi cŷi eZŰ nt`Q Ges tbZZj; weŷK` i Ki Y Kiv nt`Q|

tbZtZj AvajbK avi Yv

**AvajbK tbZtZj
, Yveij**

tbZZj; m=útK µgvMZ wšlvebv I MtelYvi dtj mgKvtj mbvZb avi Yv APj etj
cŰwYZ ntqŷQ| AvajbK tbZZj; KZ_ tJv AvPiŷYi Dci wſw Kti Mto DŷvtQ| Gme
AvPiY wkŶv tckvq wbtqvMZ KgŶZMŷYi tŶŷŷI cŰhvR`| MtelKMŷYi gtZ
AvajbK tbZvMY tKvb bv tKvb cŰZŵtbi cŰvb ntq _vtKb| AvajbK tbZvMŷYi th me
, Y_vKv`i Kvi tm_ tJv nj :

- tbZv ntZ ntj ZwtK tbZtZj AvajbK , Yveij i AvPiwYK cŰvk NUvtZ nte| wZwb
tKvbµtŷB GKbvqKtZj cŷi Pq t`teb bv|
- wZwb Zui Aaxb`t`i mvt_ AvtjvPbv Kti wm×všl MŰY Kiŷeb hvZ Zui v Zui
B`Qvbjviti Kg©m=úv`b Ktib|
- wZwb Aaxb`t`i wBKU cŰqvRbvjviti ŶlgZv AcŶ Kiŷeb Ges Zwt`i mvt_
mnKgŶwntmŷe e`envi Kiŷeb| GKK_vq ejtZ tMŷ AvajbK tbZtZj avi Yv
MYZwšK|

D`vniY`ŷfc ejv hvq th, GKRB wkŶv cŰZŵb cŰvb ev KgŶZŶ GKKfvte wm×všl
MŰY bv Kti Zui Aaxb`t`i mvt_ AvtjvPbvi gva`tg wm×všl tteb I Kg©m=úv`b
Kiŷeb| wZwb Zwt`i tK mnKvix gtb Kiŷeb Ges cŰqvRbgZ ŶlgZv AcŶ Kiŷeb|
GtZ Zui v DchŶ ghŶv cvteb Ges Kŷg`DrmwvZ nteb|

wkŶv Kvŷŷg e`e`vcbv tbZtZj , iaZj

th tKvb wkŶv cŰZŵtbi gvby, `e` mvgMŰ, A_© c×wZ, hšcŷwZ BZ`w` KZ_ tJv
Dcv`vb _vtK| Gme Dcv`vtbi gta` gvbyB meŷaK , iaZŷŶŶ gvby Zui KvŷqK wkŷev
gvbwK kŷ e`wZti tK tKvb wKQyDrcv`b Kitz cvi tJ bv| Ggb wK AZ`vavbK `ŷsŷŷq
hšcŷwZ gvbeq `úk`Qivov AKgŶ` ntq cŷo| ZvB cŰZŵtbi Af`šŷi I evBti
hveZŷq Dcv`vtbi gta` gvbyB meŷaK , iaZŷŶŶ wKš` gvby i Kvŷŷŷ Zvi a`vb-
avi Yv, Dŷi k`, AvteM-AbŷwZ, gtbvej , e`wŷtZ e`wŷtZ cŷve BZ`w` ŵv v cŷvevŷZ
nq| tbZZj; nt`Q Ggb GKwU , Y hv gvbyek Dcv`vbmgaŷK wŶwŷZKiŷYi gva`tg

ᚲ Ae GWKkb

ht_vchý e'e_v MhY KiZ emAZ Df'k" ev'evqþbi KvRþK Zi mšZ Kti | AZGe
 ukŋlv Kihþig e'e_vcbvq tbZþZji , iæZ; Acwi mxg |

G Qvor tckvMZ tbZþZji , iæZ; ubgjeþc wPwýZ Kiv hvq:

(K) mWK tbZZj; tbZv I Kgpviþ`i ci`úimeþivax gþbvfveþK `gb Kti tbZvi KZþ;
 cþqvþM mnvqK nq| mdj tbZZj; Kgpviþ`i Avkv-Avkv•ŋvi cþZ , iæZ; w`þq
 Ggb GKw Abþj cwiþek mwó Kti hv tbZvi KZþ; cþqvþM Ges GKB mt½
 Kgpviþ`i `ZtúZþvte KvþR Dþx Kti |

(L) ewj ô tbZZj; `j xq gþbvfve Mv Ges cþZôvþbi j ŋ" ARþ Zi mšZ Kti |

(M) tbZZj; mnþhvMZvi wfiÉ| mdj tbZZj; KvhRix wþgþx thvMvþhM e'e_vi gva`þg
 e'wþþZ e'wþþZ tmsn'þj-K mþúK"vcþ Ges wewfþæcþqvRb tgUvevi Rb"
 cvi`úwi K tevSvcor Ges `ŋ`msukó wélþqi RvUj Zv ubimþb mnvqK nq|

(N) mWK tbZZj; Kvhþúv`þb h_vh_ , iæZ; Avþivc Kti | tbZZj; GKw migvRK
 `ŋZv hv Rbmþúþ`i mgvþek I h_vh_ e'envþii gva`þg ce"ubaþi Z j ŋ"
 ARþb mnvqK |

(O) tbZZj; AvbþmbK Ges AvbþmbK Dfþ cKvi mþúK"MVþb mnvqK nq|

mtþcwí, tbZZj; Ggb GKw , Y, hv mg`l gvbweK Dcv`vbþK wPwýZKiþYi gva`þg
 ht_vchý e'e_v MhY Kti emAZ Df'k" ARþbi c_þK Zi mšZ KiþZ cvi | AZGe,
 ukŋlv cKvmb I e'e_vcbvq Dchý tbZþZji cþqvRbxZv Acwi mxg |



cvtVvÉi gj`vqb 7.1

A) msvŋþ DÉi cþæ

1. tbZþZji A_ŋKx?
2. `þ_ I evbþv"Gi tbZþZji msÁvi gþa" cþvb cv_ŋ" Kx?
3. mbvZb tbZþZji avi Yvi þK>`þq wél q þKvbuU?
4. AvavþK tbZþZji cþvb cþvb `ewkó" Kx?
5. ukŋlv cþZôvþb tbZþZji þKvb&Dcv`vbw metþþq , iæZþY?
6. tbZZj; GKw migvRK `ŋZv - e'vL`v Ki ab |

Av) iþbvqj-K cþæ

1. tbZþZji mbvZb I AvavþK avivi cv_ŋ" wj Ly | ukŋlv Kihþig e'e_vcbvq
 tbZþZji , iæZ; Kx?

cW 7.2

weirfoabZZj:inxZ

[Styles of Leadership]

Dfik`

GB cW tk`I Avicb-

- wdWj vi -Gi tbZZj:inxZi bvg ej tZ cvi teb;
- wj Kiv^o-Gi tbZZj:inxZ Kx Kx Zv ej tZ cvi teb;
- msj ųYgj-K tbZZj:ZĒ;msųųtc eYųv Ki tZ cvi teb Ges
- tbZtZj: μgweKivkivfivĒK inxZi tkYwefvM Ki tZ cvi teb|

**wdWj vi Gi
tbZZj:inxZ**

weirfoabekųwe` I MtelK tbZtZj: weirfoab:inxZ m=útk^oetj tQb| Zt` i gta` Gd B
wdWj vi Gi gųZ tbZZj: ų ai tbi | thgb -

- (1) Kgųųx tbZZj:(Tasks Oriented Leadership)
- (2) Avšte`w³K m=úKųm=ųxq tbZZj:(Interpersonal Relationship Leadership)

tKvb Kivųm=úv` tb weirfoab` ųZim=úbæ`w³i cųqivRb nq| weirfoab`w³i weirfoabKivthų
gta` mgšų mva tb Ges mvgwMĒK KivRiv m=úbkⁱtY Kgųųx tbZtZj: fvgKiv , iaZcYų
Giųc Kivth`Avšte`w³K m=úK^ovctbi fvgKiv tbZtZj: gva`tg`w³ncZ nq|

**wj Kiv^o-Gi
tbZZj:inxZ**

e`e`vcbv wetklĀ wj Kiv^oPvi ai tbi tbZtZj: K_v etj tQ| thgb -

- 1. tkvYgj-K ųųZmsųK tbZZj;
- 2. Kj`vYKvqx ųųZmsųK tbZZj;
- 3. ci v gkųj-K tbZZj;
- 4. AskMųYgj-K tbZZj;

wdWj vi I wj Kiv^o-Gi tbZtZj: tkYx wefvM wetklY Ki tų Avgiv eųtZ cvi e th, GB
Rivxq tkYx wefvM tK tbZtZj: `eikó`w³fivĒK tkYwefvM etj AwfvwZ Kiv ntqtQ|

GQivov eZųvb MtelYv Kivųitųgi gva`tg`w³ųvKiv^omgzųvte m=úbkⁱtYi Rb` Pvi
ai tbi tbZZj:inxZ ev tKškj D^mųeb Kiv nq| wbtP cųZ`Kiv inxZi mswųųβ cwiwPwZ
cųvb Kiv nj :

msj ųYgj-K tbZZj:ZĒ;(Trait Theory of Leadership)

GB ZtĒj D^mųeK ntjv cųPxb MĒK I tivgvbiv| tm mgųq gųb Kiv nZ tbZv Mov m=é
bv eis RbMųY Kųi| GB ZĒjbywųti tbZv nt`Qb mYvg t`tni Awakvix, eyxgub,
wųųv`v`ų, wekų`I I wmxvšl MųųtY cUž ÷ Mmwj msj ųYgj-K tbZtZj: , Ywej tK
Pvi fivM fvM KųitQb| thgb- (1) kvixiK `eikó`t kw³kvjx, Avklųxq tPnivv

ġ Ae GWKkb

BZ"wi"; (2) gubimK "eikó"t AvMó"céY, AvZ"ekjmx, AvμgYcêY BZ"wi"; (3) mvgwRK "eikó"t mnthvMZvgj-K gtbvfe, Avšte"ir³K "ġZv, cġimtb "ġ BZ"wi Ges (4) Kvh"máúv`b "eikó"t Df`vMx, j ġ" ARġb Abgbxq, wbišli tPóvKiġYi gtbvfe BZ"wi |

cwiw"iZi tġġġZ tbZZ;ZĒ; (Situational Theory of Leadership)

GB ZtĒji gj- K_v nj tKvb weġkl cwiw"iZtZB tbZvi Awefġe NtU| Giġc tbZtZji gj-K_v nj, th weġkl cwiw"iZtZ tbZv Kvr Ktib tm cwiġek l cwiw"iZ tbZtZji ōviv meġak cġveZ nq| cwiw"iZi tġġġZ tbZviv ntj b- imkqvi tj wj b, eġUġbi Pwġġ, Avġwi Kvi iaRġfĒ Ges Pġtbi gv l tmZx|

Abjvix tbZZ;ZĒ; (Follower Theory of Leadership)

GB ZtĒji D"veK ntj b Gd GBP ÷ "vbtvWġ GB ZĒ; Abjvix GKgvĪ AbjvixivB tbZZtK KvhRi Kti tZvtj | Giġc tbZtZji gj- wġĒ nj Abjvixiv| Kvi Y Abjvixiv tmB e"ir³tK tbZv etj "Kvi Kti wġb Zvt`i mvgwRK cġqvrB l e"ir³MZ Afve AwfthvM cġY Kti Zvt`i mšġo wearb KitZ cvġib| A_ġ th tbZvtK Abjvix ev Aat`bt`i Avkv-Avkv"ġv, Afve-AwfthvM tgUvtZ Zrci etj gtb Kiv nq ZġKB Abjvixiv tbZv wntmte tġtb tbq|

Askx`wi Zġj-K tbZZ;ZĒ; (Participatory Theory of Leadership)

Askx`vixZġj-K tbZtZi Aat`bt`i mvt_ Avjvc Avtj vPbv Kti mKj KgRvŪ máútk" wmxvšĪMġY Kiv nq| dtj `tj i mKj m`m" ce"ġ_tKB Rvġbb Kvi `wqZ; Kx, KLb KitZ nte, e`_ġtj Kx ġwZ nte| ZvB Giġc tbZZtK MYZwšK tbZZ;ejv nq| GB aitbi tbZZ; máútk" cieZxġZ wek` Avtj vPbv Kiv ntqġ|

tbZtZi μgveKvk wġĒEK i wZ

wMZ cĀvk eġti weġkji wefġbet`tk tbZtZi wefġbew K wbtq eŪ MtelYv ntqġQ| Gme MtelYvtK Awakvsk MtelK tbZtZi wZbvU tgšwġ K i wZ wntmte wefirB KtiġQb| wbtP G, tjvi cġZ"KuU máútk"Avtj vPbv Kiv nj |

^^ZwšK tbZZ;

^^ZwšK tbZtZi i wZ GKvU Avw` avi Yv| ga`hMxq mvgšġ`i gta" G avi Yvi cġvrb" j ġ Kiv hvq| ZrKvj xb mvgwRK, A_ġwZK l ivR%wZK Ae`v wġj ^^ZwšK| G aitbi tbZtZi tbZvi nvtZB meġġgZv tK`ġfZ _vtK| tbZvB meiKg wmxvšĪMġY Ktib| Kgxġ i wmxvšĪMġYi mġhvM t`lqv nq bv| AbjvixivMY tbZvi tLqj Lġxi Dci wbfġ Kti| ^^ZwšK tbZv Abjvixit`i mly-mġeav l AvtelM-AbjvixitK Dġcġv Kti _vtKb| G aitbi tbZvi `p weġkjm GB th, Zui Ae`vb, Ávb, kvw`lev cġv`vi cġvġbi ġġgZv ZvtK wbggZwšK Dcvtq tbZZ;Kivi Awakvi w`ġtqQ| Zte tKvb tKvb ^^ZwšK tbZv Kvh"máúv`tbi Rb" f"wZ cġkġ Ktib, tKD tKD kvw`lcġvb Ktib| Avevi tKD tKD cġv`vi cġvġbi gva`tg wZmġyf AvPiYI Ktib|

^^Zwisk tbZZj; mfu mivim MtelYvq Rvbr hvq th, ^^Zwisk tbZv Zvi
Abyvix`i mfuKbgiefc avi Yv tcvlY Ktib:

- Kivr ciz gvbyj i rfvieK Abxrv vtK Ges mshvM tctj B Zvrv dmk t`q;
- Kov vbqsy, ej cqvM Ges kvv`li fq t`vlLtg Abyvix`i mehaK Kvhmuv`tb
eva` Kitz nq;
- mivari Y gvbyj `vqZj GovtZ Pivq Ges mehaK ubivcEv Avkv Kti;
- Zv`i Avt`k vbt`fki gva`tg cwi Pvi Z I vbqsz Kitz nq|

MYZwisk tbZZj.

MYZwisk ev Askv`vix tbZZj; ^^Zwisk tbZtZj; mfuYecixZ| tbZtZj G imvZ
mivuvZKkvj i | Gifc tbZtZj; tbZvMY Abyvix`i ciz bgbrq gbrvfvie tcvlY Ktib
Ges Zv`i ciz Av`verb vtKb| mfvvsl MhtYi cte`msukw velq Zuiv Abyvix`i
mfv` civgk`Ktib Ges mfvvsl MhtY Zv`i AskMhtYi mshvM cvvb Ktib| G
imvZtZ cksm I tcvlYvgj-K cvj`vtii gva`tg Abyvix`i Kivr Drmrv cvvb Kiv
nq| G aivbi tbZtZj; cizvibi thvMshvM e`e`v Eavvvgx I vbqdvx Dfq ckvv nq
vtK| mtefcwi GtZ Abyvix`iMY ht`o cwi gvty raxzv tfvM Kitz cvti Ges bgbrq
vbqsy e`e`vi gta` t`tK vbr vbr Kvhmuv`b Kitz cvti, hv cizvibK DEtivEi
Dbvzi ct` Gvmtq vbtZ mrvqZv Kti | th mg`lcizvib `q I AvfA Kgr`vtK Ges
hviv vbt`R QvovB raxbvite Kvr Kitz cvti tmLvib tbZtZj G imvZ teuk Kvhriv|

MYZwisk tbZZj; Avak mnR tbZtZj Dcvq etj PviZ Kiv nqqtQ| Gifc tbZtZj
%ekó` nj :

- mivari Y tvvK Kvr AcQ` Kti vrv| Kvr Zv`i vbrKU wektg ev tLjvi gZB
rfvieK;
- tbZvi Abt`cYvq Kgrv hv` tKvb Kvhmuv`tbi` rkvZ. cvb nq Zte tm Kvr
Zvrv`ZtZv`vteB mfu`b Kti, Gi Rb` ej cqvM ev fmvZ cvk`bi cqvRb
nq bv;
- mivari Y tvvK tm me Dtik` ARfb cizkiz nq th`tv Zv`i Pvn`vi msho
weavb Kti;
- cizvib KgpZ e`v`t`i Ab`vb` Pvn`vmg`ni msho weavb m`e` ntj tbZv Zv`i
Avt`ghv I Dbvbj-K Pvn`v ct`Y Avte`b mjo Kti fvj dj tctZ cvtib;
- Dtik`vej ARfbi cwi tcvlYtZ Kgrv i vbqsy mnRZi nq|

gy tbZZj.

G aivbi tbZtZj; Kgrv AZ`vak raxzv tfvM Kti vtK| GtZ tbZv tKvb KgrvK
vbt`R cvvb Ktib vrv| G tkYxi tbZv wefvbKgrv gta` mgshkvix vntmte Kvr
Ktib| KgrvB Kivr cwi Kivb Kti Ges vbr`j j`v` vbr`^tKsktj Kg`muv`b
Kti | GLvib tbZv vbt`R cvvibi e`tv vbt`RB GKRb Kgrvntmte Kg`muv`tb Ask
tbb|

ᄁtj i Kgrᄁv enygvb Ges ᄁᄁ ntj , Kgrᄁ i ᄁbR ᄁbR Kvr mᄁᄁÜ mᄁᄁK Ávb ᄁvKᄁj G
aiᄁbi tᄁZᄁj. AZ ᄁᄁ Kvhᄁi nqᄁ MᄁelYvi ᄁᄁᄁᄁ tᄁZᄁZᄁj G iᄁᄁZi cᄁᄁqᄁM cᄁᄁ cᄁᄁᄁ-
ᄁKbbv huiv MᄁelYv Kᄁib Zᄁiv mKᄁj B weÁ Ges ᄁbR KᄁᄁRi cᄁZ ᄁbᄁvevb ᄁᄁKbᄁ/
ᄁᄁᄁᄁ MᄁelYv KᄁᄁR tᄁZᄁZᄁj G iᄁᄁZi cᄁᄁqᄁM AwakZi Kihᄁix nᄁeᄁ



cᄁᄁVvᄁi gjᄁvqb 7.2

A) msᄁᄁB Dᄁi cᄁᄁ

1. ᄁᄁWj ᄁᄁi gᄁZ tᄁZᄁj. KZ cᄁᄁvi I Kx Kx?
2. ᄁᄁWj vi I ᄁj KᄁᄁUᄁᄁ tᄁZᄁZᄁj ᄁKᄁᄁ wefvᄁMi ᄁᄁᄁᄁ Kx?
3. MᄁelYvi gvaᄁᄁg Kq aiᄁbi tᄁZᄁj. iᄁᄁZ Dᄁᄁveb Kiv nᄁᄁᄁQ I Kx Kx?
4. msj ᄁᄁYgj-K tᄁZᄁj. iᄁᄁZi ᄁᄁᄁᄁ Kx?
5. cᄁᄁᄁᄁZi tᄁᄁᄁᄁZ tᄁZv Kᄁiv?
6. ᄁᄁᄁZᄁᄁᄁᄁ tᄁZᄁj. Kx? ᄁᄁᄁZᄁᄁᄁᄁ tᄁZv Zvi Abyᄁᄁᄁᄁᄁᄁ i mᄁᄁÜ ᄁKᄁᄁc ariYv tᄁvY
Kᄁib?
7. MYZᄁᄁᄁᄁᄁ tᄁZᄁZᄁj ᄁᄁᄁc ᄁKᄁᄁc?

Av) iPbugj-K cᄁᄁ

1. MᄁelYvi gvaᄁᄁg DᄁᄁᄁeZ tᄁZᄁj. iᄁᄁZi wekᄁ Avᄁj ᄁPbv Kiabᄁ
2. tᄁZᄁZᄁj ᄁᄁᄁᄁKᄁᄁᄁᄁᄁᄁ iᄁᄁZ ᄁᄁᄁᄁᄁ weeZ Kiabᄁ

cW 7.3

tckvMZ tbZtZj weKvk I Dbqtb cŷuqv
[Development of Professional Leadership]

Df`ik`

GB cW tkfI Avcwb-

- tbZv ubePb ev ubtqvM i az; e`vL`v Ki tZ cvi teb;
- tbZv ubePb ev ubtqvM tKŠkj eYb`v Ki tZ cvi teb Ges
- weifbæaitbi cŷkŷY Kvhpitgi gva`tg tckvMZ tbZtZj weKvk I Dbqtb cŷuqv weZ Ki tZ cvi teb|

tbZv ubePb ev ubtqvM i az;

ukŷv Kvhpitgi j ŷ` cŷ`ij Z mgtqi gta` ARb Ki tZ ntj tbZv ubePb e`AvmbK cxwZ e`envi Ki tZ nte| ubtqvM ev ubePbKvtj D`P tgavi e`w`tk ij wLZ, tgŠwLK, gtbv`AvmbK I `v`MZ cixŷv Ges cŷk k fwiwdtKktbi wfiE`Z A`vqrvite ubtqvM ci e`bqv`x cŷkŷYi e`e`v Kiv GKvŠcŷqvRb|

AZ:ci ubtqvM ev ubePbKZ. KgRZMYtK tckvMZ tbZtZj th th w`tk, thgb `ŷZv, AwfAZv, Kj v`KŠkj, Avb, ŷYi Afve itqtQ cŷkŷYi gva`tg Zv cŷYi e`e`v Ki tZ nte| Avgv` i t`tk ukŷv e`e`vq we`kl we`kl tŷtŷ tckvMZ `ŷZvi Afite tbZtZj; v`bi Afve itqtQ, thgb- GKv`Ww`gK ZE`eavb, ukŷvi gj`vqb, MYmtPZbZv ewx, epEi Kvm e`e`vcbv, temiKwi cŷZv`b i ŷYvteŷY, ukŷv`u`g Dbqtb, gj`vqb, bevqb, AvBGgGm (Information Management System ev Z` e`e`vcbv cxwZ), Z` cŷwŷ (Information Technology ev IT), `vbxq DcKiY w`tq ukŷv DcKiY cŷZKiY BZ`w` | G mKj tŷtŷ tckvMZ Dbqtb cŷqvRbxq e`e`v MŷY Ki tZ nte|

tbZv ubePb

ukŷv e`e`vi mKj chŷq mKj aitbi tbZtZj. msuk-ó ŷYewj i weKvk I Dbqtb e`e`v MŷY Ki tZ nte| tKbbv GKrb tbZv`K mvaviY cŷvmbmn ukŷv w`lqK e`u aitbi ŷY I thw`Zvi Awakvix ntZ nq| GK_v mZ` th, Pwv`vi Z`z`bvq tckvMZ `ŷZv m`ubætbZvi msL`v Acŷz`| tbZv ubePb tKvb GKK cxwZ e`e`üZ nq bv, KviY GK GKw cxwZ GKw we`kl Kv`Ri Rb` D`w`eZ| tm Kvi`Y ukŷv cŷZv`bi weifbæchŷqi tbZv ubePb weifbæcxwZ I tKŠkj e`e`üZ ntq `v`K| w`tgætbZv ubePb KivZcq cŷuqv ewŷ nj :

cŷ`vbq: weifbæukŷv Awv`Bti i tckvMZ tbZv ubePb cŷvMZvite cŷ`vbq cŷuqv e`e`üZ nq| w`gæI ga`g chŷq t`tk AwfAZv I `ŷZvm`ubæukŷv KgRZŷK cŷ`vbZ w`tq cieZx`D`P cŷ` ubtqvM w`tq tbZtZj. cŷv`bi e`e`v Kiv nq|

ᐃᓕᓴᑭᑭᑦ ᓂᓕᓴᓴᓴ: Gž EaŸZb tckvMZ `ŕZvmꞰúbæᐃᓕᓴᓴᓴ cÅZòvb ᐃᓕᓴᓴᓴᓴ ᐃᓂᓴᓴᓴ tcüY Kti tckvMZ `ŕZv msukó welta nrtZ-Kjtᓴ ᓂᓕᓴᓴᓴᓴ cüvb Kiv nq/ ᐃæ l ga'g chŕqi tZv i tK Gfvte ᓂᓕᓴᓴᓴᓴ ᐃᓴᓴ tckvMZ `ŕZvi weKvK NUVtbr nq/ dtj KvŕRi , YMZgvb ᐃᐃöZKiY mꞰe nq/

AbvgwbK ᓂᓕᓴᓴᓴ (Formal Training)

wetkl wetkl tŕŕĀ ev welta cvi`krŕckvMZ ᐃᓕᓴᓴᓴ cÅZòvb wewfbae`ŕi i tZv i Rb` AbvgwbK ᓂᓕᓴᓴᓴᓴ e'e`v Kti `vŕK/ thgb- Avgv i t`tk ᐃᓕᓴᓴᓴᓴ welaqK tckvMZ D"pzi l mgKvjxb mgm`v mꞰÜxq bvb welta tbc, brtqg, AvB B Avi, evDwe, Gbimüwe ᐃbqvgZ l mvguqK ᓂᓕᓴᓴᓴᓴᓴ e'e`v Kti `vŕK/ GQrov t`tk l weta`tk AbvgwbKfvte wewfbae cÅZòvb bvb aiŕbi ᓂᓕᓴᓴᓴᓴᓴ AvŕqvRb Kti `vŕK Ges cÅZòvb i tZe,` ZvtZ AskMöY Kti ᓂᓕᓴᓴᓴᓴ MöY Kti b/

(K) tmvgbvi Ges lquKŕtci gva`tg ᓂᓕᓴᓴᓴ (Training through seminar and workshop): mvariY e³Zv l e`enwi K Kvthŕ gva`tg G aiŕbi ᓂᓕᓴᓴᓴᓴ t`qv nq/ cÅvbZ cwi K i bvb bwiZ, e'e`vcbvi tKŕkj BZ`w` G aiŕbi ᓂᓕᓴᓴᓴᓴ Aŕŕfŕ `vŕK/ D"p chŕqi e'e`vcK t` i Rb` G aiŕbi ᓂᓕᓴᓴᓴᓴ AwaK KvŕRix/

(L) NUbv chŕjvPbv c×iZi gva`tg ᓂᓕᓴᓴᓴ (Case study method): D"p chŕqi ᐃᓕᓴᓴᓴ e'e`vcKMYtK gvbwEK mꞰüK`Abvgwb Ges Kwii Mwi Ávb cüvŕbi Rb` G aiŕbi ᓂᓕᓴᓴᓴᓴ KvŕRix/ G c×iZtZ ᓂᓕᓴᓴᓴᓴ AskMöYKviŕ i GKüW wetkl NUbv ev mgm`vi mgvavb Ki tZ etj b Ges cŕqvRbtvŕta ᓂᓕᓴᓴᓴᓴᓴ mrvqZv Kti b/

(M) AskMöY l chŕŕŕŕŕi gva`tg ᓂᓕᓴᓴᓴ (Observation with participation): G e'e`vq ᓂᓕᓴᓴᓴᓴ MöYKviŕ tZv AwfÁ l `ŕ ᓂᓕᓴᓴᓴᓴ Ki Aaxŕb Zü ᐃŕ`Rbqv ᓂᓕᓴᓴᓴᓴ MöY Kti b/ G c×iZtZ ᓂᓕᓴᓴᓴᓴᓴ MöYKviŕ tZv ᓂᓕᓴᓴᓴᓴ Ki ᐃŕ R l civgk`ŕgvZvŕteK KvR tkŕLb/ G c×iZi KvŕRwii Zv ᐃŕfŕ Kti ᓂᓕᓴᓴᓴᓴ Ki Ávb, `ŕZv l ᓂᓕᓴᓴᓴᓴ `vŕbi Kj vtKŕtj i Dci/

(N) bu'wfbq c×iZi gva`tg ᓂᓕᓴᓴᓴ (Role playing method): G c×iZtZ GKüW wetkl mgm`vi KtqKüW PwiĀ mŕó Kiv nq Ges cŕZ`K AskMöYKviŕ tK GK GKüW PwiĀ Awfbq Kti `ŕq `ŕZv cŕkŕ Ki tZ ejv nq/ AskMöYKviŕ i gŕa` tKD e'e`vcK, tKD Kgvŕ fvgKvq Awfbq Kti b/ G c×iZi gva`tg ᓂᓕᓴᓴᓴᓴ cüvŕb PgrKvi dj cvl qv hvq/

AbvgwbK ᓂᓕᓴᓴᓴ (Informal Training)

Avgiv AbvgwbKfvte tKvb tKvb welta ᓂᓕᓴᓴᓴᓴ tctq `vK/ ᐃᓕᓴᓴᓴᓴ e'e`vq AbvgwbK ᓂᓕᓴᓴᓴᓴ ᐃŕŕŕŕi i nŕq `vŕK/ thgb:

(K) Avj vc-Avtj vPbvi tFzi w`tg ᓂᓕᓴᓴᓴᓴ MöY Kti `vŕK/ wewfbaKvŕR AŕbK ᐃbgael ga` chŕqi KgŕZŕ` ŕguj Z nŕq ᐃŕŕŕi i mgm`v mꞰüŕK`Avjt vPbv Kti Zvi mgvavb mꞰüŕK`ᓂᓕᓴᓴᓴᓴ tctq `vŕKb/

ᚰ Ae GWKkb

(L) *wefbæcðóvbi mgm̃v, AMMwZ, Kvhþrg chþeŕŕY Kþi GZ`welþq cðkŕŕY MðY Kþi _vþKb|*

(M) *wefbæchþqi KgRZMþYi gþa` gZ wewbgq Kþi msuk- ó welþq cðkŕŕY MðY Kþi _vþKb|*

wetkl aiþbi cðkŕŕY

wkŕŕv mdi, wetkl welþq e³Zui AvtqvRb, A`vqx cþ`vbqþ, Awatekb AvtqvRb ev Awatekþb thM`vb, mgm̃v welqK case study | c` AveZþbi gva`tg cðkŕŕY MðY Kþi tbZþZji `ŕZvi Dbqþ Kiv hvq|



cvtVÐi gj`vqb 7.3

A) msuŕŕB ÐÐi cðkæ

- 1. *tbZv wbeþþbi _iaZjKx?*
- 2. *tbZv wbeþþb mi vmi wbþqm cðvb cðuqv mæav Kx?*
- 3. *tbZþZji wKvþki AvbþmbK cðkŕŕY cðuqv _þjv Kx?*
- 4. *AvbþmbK cðkŕŕþYi gva`tg wKfvte tbZþZji wKvk mvab mæe?*
- 5. *tbZþZji.wKvþk wetkl aiþbi cðkŕŕY cðuqv DþjL Kiab|*

Av) iþbvj-K cðkæ

- 1. *evsj vþ`þki wkŕŕv e`vq tbZv wbeþþbi tKþkj _þjv Avþj vþbv Kiab|*
- 2. (K) *cðkŕŕþYi gva`tg tbZþZji wKvk | Dbqþbi tKþkj _þjv Kx?*
(L) *þvKvþ Kvj xb cðkŕŕþYi tkYwefvM e`vL`v Kiab|*
- 3. *AvbþmbK | AvbþmbK cðkŕŕþYi gva`tg tbZþZji.wKvþki avc _þjv wæZ Kiab|*

cW 7.4

ik`ivi , YMZ e`e`icbvq tckvMZ tbZtZj veivfba`K

[Professional Leadership for Quality Management of Education :
Different Dimensions]

Df`ik`

GB cW tk`l Av`cib –

- tckvMZ tbZtZj tg`ij K`enkó`mgn`Dfj - L Ki`tZ cvi`teb;
- tckvMZ tbZtZj m`avi Y Kvh`ejj we`Z Ki`tZ cvi`teb Ges
- tckvMZ tbZtZj D`m`tebrgj-K fvgKv e`vL`v Ki`tZ cvi`teb/

tckvMZ tbZtZj tg`ij K`enkó`mgn`

tbZZj.nj GKvU gbbkij c`uqv/ bvbv ai`bi Dcv`vb mg`stq G c`uqv mPj `vtK/ tbZtZj fvgKv nj Abyvix`i gtb AvbMZ`, mek`m, Drmiv-Di`xcbv RvMv`bv hv`tZ Kti` tbZv, c`Z`vb, Abyvix I Acivci mevi Kj`vY mmaZ nq/ ZvB tbZtZj `tfc KZK` ,tjv`enkó`i Avtj`vtK e`stZ nq/ vbt`tbZtZj KZ` ,tjv meR`bxb`enkó` Dfj`L Kiv nj :

tbZZj.GKvU` , Y

tbZZj.GKvU e`v`MZ` ,Y/ GvU Ggb GKvU `I`gZv hv` Abyvixi gta` tc`Yv m`pó Kti` / dtj` t`Qvq` `vqZj` KZ`e` m`uv` `tb vbt`RtK` vbt`qmRZ` Kti` Ges cvii Yv`tg c`Z`v`v`bi mmeR` g`j mmaZ nq/

tbZZj.Av`ste`v`K

tbZZj.nj Av`ste`v`K c`fve hv` Abyvix`K tbZvi vbt`Rbv Abyvi Y Kti` `Ztc`Yvii` Z ntq Kg`m`uv` `tb Av`j`c`Yv RvMvq/

tbZZj.avivemK` c`fveZKiY` c`uqv

tbZZj.nj GKvU avivemK` c`uqv hv` gvb`i AvPi`YtK c`fveZ` Kti` tbZv I Abyvixi gta` vbeo m`uK`v`cb Kti` / dtj` Abyvix`i gvtS avivemK`fivte KZ`e` m`uv` `tbi tc`Yv m`pó nq Ges cvii Yv`tg tbZtZj` c`Z` Av`v Av`iv Mfxi nq I Ktg`Av`Z`v`B.NtU/

vetkl` cvii`v`ZtZ` Kg`m`uv` b

Kvh`Ri I eij`o tbZZj.vetkl` cvii`v`ZtZ` Kvh`m`uv` `tbi `g`f eimbv RvMvq/ dtj` cvii`teukK A`šivq` `h`fZ` ntq Ab`kj` cvii`tek Mto DfV/

tbZZj.GKB` ai`bi` AvPi`Y` c`fveZ` Kti`

tbZv Abyvix`i` c`Z`KtK` Ggbfivte c`fveZ` Ktib` thb` Zviv` mKtj`B` GKB` ai`bi` AvPi`Y` Ki`tZ` vktL/

tbZtZj` j`I` mmeR` Dbqb

tbZtZj` gva`tg` Abyvix`i` gtbvej` , vbgv`b`v` I` mivm` Ggbfivte` D`ximeZ` Kiv` nq` hvi` dtj` c`Z`v`v`bi` Dbqb` aviv` Ae`v`nZ` `vtK` I` v`v`Zkxj` nq/

**tbZZ;AvZwekjm
evoiq**

tckvMZ tbZZ;Abynixi AZwekjm evoiq hv AwakZi dj cġbi Rb" mniqK nq|

tbZZ;eüglyx

tbZZ;GKglyx bq| tckvMZ tbZZ;tbZv I Abynixi gta" gZ weibgtqi mthvM mwi Kti | GtZ Zviv GtK Actii cġZ kxvkij nq|

tbZtZj maviY Kvhewj

tbZZ;Abynixi Kj "tYi Rb" Ges Gi cġvb KivR nj tckvMZ `ŋZvi DfErtivEi ewxi mthvM mwi gva"tg cġZövtbi Dbqeb Kiv, tckvMZ tbZZ;w tq cġZövtbi mweR I mivK w K wbt`Rbv cġvb I tbZv, Aaxb` KgRZPKgPvixi civgk`I cwi Kí bvi mgšq mivab Kti mKtj i Rb" GKw AwfbæKvhewj cġqb Kiv| ewj ô tbZZ;`vfb tbZv wbtgæ³ Kvhew m'ubæKti `vfb|

weŋiva gvgismv

tbZv hwt`i K wbtq j ŋ" ARfb cġvix Zwt`i gta" gZweŋiva- thgb, GKw ġ feb Mŋgi tKvb Astk `wcz nte, Kvt`i `t`P AwakZi Abktj nte, `vKv `vfwieK| DEg tbZvi GKw AZ`šġ, iæzcy`wqZij nj Gt`i gta" gZvwbtk`i Aemv NwUtg meŋvZ I mšġI RbK wvvtšġAviv|

BswMZ `vb

GKRb tbZv mKšktj wKfite KivRw wZvb KiŋZ Pvb Zvi BswMZ t`b| thgb- ōŌAvig wekjm Kwi G KivRw Gfite KivB mteŋEg nteŌ| mivmwi Avt`k bv w tq Gfite cġlevKvti gZvgZ cġvtbi mweav GUVB th BswMŋZi AvtjvtK AbynixiMY t`QvcŌYwv Z ntq KivR Kti | `xNwngtg G aiŋbi cġPov Lg dj cġh-nq|

msMVvbK

tbZvi Kvhewj msMVtbi/cġZövtbi wefvMxq Kvhewj I msukw Kgx`i `wqZij gta" mvgAm`cYnŋZ nte| tbZvi mRbkij wPšġ thb cġZövtbi KgEŋEbi cwi cšġ bv nq eis G, tji vi cġZövbK ifc t`qvB tbZvi `wqZij|

AeinZKiY

mivK wbt`R cġvb Kiv tbZvi GKw, iæzcy`wqZij| GUV wj wLZ Ges tgšwLK `ŋB ntZ cvti| thŋZzbtZvi ewgEiv I wPšġaviv D`P chŋqi, GRb" Aa`bt`i w elqmgv ewštg t`qv cġqvRb| wefwæKgx` gta" thvMthvM `vcb Kiv Ges Dchŋ mgtg I `vfb wbt`Rvej tcšwvb wvöZKiY tbZvi `wqZij| D`vniY`ŋfc ejv thŋZ cvti th gnvcwi Pvj K A_er cwi Pvj K hLb tKvb wbt`R t`b tmw mivK ntZ nte Ges mivK mgtg msukw`i wku tcšwŋZ nte|

cġZvbwZKiY

tbZv Zvi cġZövtbi gly" eiv³ ev cġZvbw| cġZövtbi wZvb glycvl| cġZövtbi mKj e`vcti wZvb cġZvbwZj Kiteb| cġZövb m'utK`evBtii tjkvt`i avivv tbZvtK wbtqB Mto I tV| dtj Zvi mvtg thgb cġZövb Meŋeva KiŋZ cvti, tZgub Zui `Yg cġZövtK tnq Kti |

Z`viK I wqšY Kiv

cġZövtbi th `tiB tbZv Ae`vb Kiab bv tKb Zui wvšŋgn ev`evqtbi Rb" Kvhew cwi Kí bv `Zwi Kiv, wbt`R t`qv I mgšq mivab Kivi `wqZij Zui| maviYZ

Gme KvR AþK Aa`b ZþK mnvh` Kþib ev GKwU Gj vKvq wKQyKgr`mnhvMzv
t`b| G mKj e`w³i KvRi Z`viK l wqšY Kiv, Zvt`i fjt`au mstkvab, mgtqi
gta` KvR m`uv`b Kiv tbZvi `wqZj| eZgvtb cþž A_`e`tq miKvi wKŕv we`lþi th
KgŕwP ev`evqb KiþQb, bvbvb wKŕv DcKiY w`t`Qb, miKwi Aþ`B Awakvsk wKŕvi
e`q tgUvtbv n`t`Q, tm KvŕY msukw tbZv/e`e`vcKt`i Z`viwKi KvRi ,iaZ;
Acwi mxg|

Drmin cõvb

tbZv hLb Zvi Aa: `bþ`i etjb th, Zviv cõZõvtbi Rb` hv KiþQb Zv gj`evb l
,iaZc`ZLb `fveZB Zviv Awak Drmin l D`ixcbvi mvt` KvR Kiþeb| GKRB
fij tbZv me`v Zui Abyvixt`i DrminZ Kþib Ges GtZ Zviv `Z: ùZvŕteB
cõZõvbK Dþ`k` ARþb Zrci nq|

cõsmv Kiv

cõZ`þKB wR wR KZ.KvRi cõsmv Avbw`Z nq| kb` tZvltgv` fvj bv ntj l
m`uv`Z DEg KvthP Rb` ht`vchŕ cõsmv Aek`B Kgr`K Awakzi Kvth`m`uv`þ
DrminZ Kþi| tbZv AKCU wPþE cõsmvi ðviv AbMyvxt`i wefbaecKvi gb`hwEþK
Pwv`v ci-Y KiþZ cþib|

**`wqZjtgþb tbqv Ges
Aa: `bþ`i Av`v mþõ
Kiv**

wefbae`w³ tbZvi Aaxþb KvR Kþib| Zvt`i gþb Av`vteva mþõ Kiv, wivcE`v weavb
Kiv, mwK cþ`_vKtj evnev t`lqv, msKUGq mgtq wivcE`vi e`e`v Kiv tbZvi
Ab`Zg cõvb KvR| mtefciw, `wqZjtbqv, weþkl Kþi cõZõvtbi tKvb `þvŕ gytZ`
tKvb e`_Zvi tevSv Kta tbqvri gZ e`w³Zj l gtbvej `vKv tbZtZji cwv Praq|

GKRb tbZvtK maviYZ Dcti wj mZ me `wqZj cvj b KiþZ nq| Zte Gi evBti l
tbZvi AþK, wj `wqZj `vtK| G, tji vi gta` KtqKwU Dþj lþhvM` `wqZj weþkl ev
D`wtebx `wqZj Avl Zvfž Kþi Avtj vPbv Kiv thþZ cþi | wKš`gþb ivLv Avek`K th
G, tji vi gta` l tKvb tKvb `wqZj Kvj l cvlþt` maviY `wqZj Avl Zvfž nþZ
cþi |

tbZvi D`wtebx ev weþkl fvgKv

**kg wefMRibZ
Amgev`ixKiY**

tKvb cõZõvtb wefbae`w³mi `wqZj Avj v`v Avj v`v n l qvq wfbawfbae`w³ wfbawfbae
KvR wbtqwrZ `vtKb| wZvb hw` iayZvi wþRi `wqZjvB eo Kþi t`lLb Zvntj
cõZõvtbi mvwMk j`ŕ` ARþ wevNz nþZ cþi | GB aitþi gþbvfetK mstkvab Kþi
tbZvi `wqZj nte wefbaekvlv l cõvLvi Kgr`ZP l Kgr`vixt`iþK j`ŕ` ARþb cõwv Z
`w³v½ wbtq l Avšhi Kfvte KvR KiþZ AYgõvZ Kiv|

**enĒg `wqZj
MAY Kiv**

eþK fviþZ th cõvmb e`e`v Mto DþvQj tmLvþb cõvmKt`i mshgx nevi Av`k`Qj
Ges tmBfvteB Zviv Dci`þ`i KvQ t`þK cõkŕY tctZb| ZþK hZUKz`wqZj t`qv
nþZv ZZUKB wZvb cvj b KiþZb Ges Gi teþk Kivlv tkþ gþb KiþZb bv| ZvQov
tKvb we`lþq SþK tbqv cõvmtKi `wqZj evBti wQj | e`_Z tmKvtj ivtõŕ fvgKv wQj
bMY`| tm mgtq `vbkyj e`w³ ev m`Qj e`w³þ`i Dþ`vþMB wKŕv cwv Pwv Z nZ|
wKwŕþZi nvi l wQj Kg| Zte eZgvtb mgtq miKvi wKŕv we`lþi i j`ŕ` e`vcK `wqZj
cvj b KiþQb|

eZġyb miKvi RbMġYi miKvi | ukġv RmZi tgiæ Ū | tgiæ Ūnx b cŲYx thgb tmvRv nġq `wvġZ cvġi bv, ukġv ewRZ RmZi I GKB `kv | ZvB miKvġi i Dġj LġthvM" eġqi LvZ nj ukġv LvZ | ukġv uefvġMi th me KgRZPGB KgġmP, ueġkl Kġi Dbqbgj-K ukġv Kvġġg evġevqġb ūbġqmRZ _vġKb Zġġ iġK MZvbMvZK `vqZj cvj b Kiġj Pjġe bv, RvZxq `vġ_Ųġġ iġK epġg I ewæġ `vqZj Kvġa Zġj ūbġZ nġe |

**cŲj Z miKwi bMZ,
ūbġġi ms`vi
mvab Kiv**

Avġvġ i ġġki cġvmb HwZnMZfvġe iġYKxj | tm KvġġY AvBġbi evBġi KvR KivŪv memġġ mġvPxb bq | GKŪJ `vaxb ġġki miKvġi i PŠġ | Av`kŲvfbæGes me ūbġġ Kvby tmBgZ nI qv Avek`K | GRb" ukġv eġ`vq hviv cġvmbġi Dġzchġq iġqġQb Zġġ iġK eZġyb ukġv eġ`v mġvġK`cġj vcvj Avġbi AwæKvix nġZ nġe | AġbK mġġ ZvŪv ūbeġv ūbġ`R Rvix Kġi mġvġKfvġe KvR Pwġġq tbb | memġġ GŪv Kvġġi nq bv ev `vNġvġxb mġġqi cġqvRbI tġŪvq bv | tm Rb" mġġqi Pwv`vi mġġ msMvZ tiġL AvBb Kvby ms`vġi i Dġġ`vM MġY KiġZ nġe |

**cŲZvġbi Dbqġb
D`mġebx ev D`vġebx
kv` mġvi Kiv**

ukġv ue`ġġi i KvġR ūbġqmRZ GKRb mdj I tckvMZ tbZvi `ġZvi ūekvġ cġvmb PjġvġZ cŲj Z eġ`v ūbġqB mšb `vKġZ cvġi bv | tKbbv GB eġ`vq bZb tKvġ kv` ev D`vġebx kv` i Afvġe _vġK | ZvB cŲZvġb cŲ mġviġi i ġvæġġ beZi D`ġġ hvġZ Kgġv Dġġk" ARġbi wġġK GvMġq thġZ cvġi GRġb" tbZvi i ayAKvšġ cwi kvġB nġeb bv eis mKjġK GKŪZ Kġi D`vġj fvġelġZi wġġK GvMġq thġZ AbġvġYZ Kġeb | Gme KvġR ZvŪv ūbR`^ewkŲ" ev AbjvM _vKv Avek`K | GQvov ukġv uefvġMi ukġv KġmP evġevqġb th me KgRZP RvŲZ AvġQb MZvbMvZK Kvġġej i evBġi I Zvġi i AġbK `vqZj ġġm hvġ | GKRb ūbŲverb I Kġġġ`vMx KgRZP ūntġte Zġġ i tckvMZ tbZġZj AvPiġY I Kgġġj Zvġ Dctiv` ,ġYi AwæKvix nġZ nġe etj Avġiv Avkv KiġZ cvġi |



cvġVvġi ġj`vq b 7.4

A) i Pbvġj-K cġæ

1. tckvMZ tbZġZj tġšvġ K `ewkŲ" ,ġv Avġj vPbv Kiġb |
2. GKRb tbZvi mġvi Y Kvġġej ūeZ Kiġb |
3. tbZvi mRbkxj ,Yvġj i ūek` ūeiY w`b |

cW 7.5

tbZvi , Yveij
[Qualities of a Leader]

Dfík

GB cW tkfI Avcwb –

□ tbZvi weifbæ, Y weeZ KiþZ cviþeb|

tbZvi , Yveij

GKRb tckvMZ `ŋ| tbZvi gta` th me ,þYi mgvtek f`Lv hvq Ges tm m½ th me , Y_vKv Avek`K wbtæZv avivevwnKfvte weeZ Kiv nj :

kviwi K m̄Zv

tbZZi.kŷmva` I teŷwK KivR| ZvB tbZvþK kviwi K I gvbumK Dfq cKvi kŷ`vþbi gva`tg KvR m̄ubæKiþZ nq| tbZvþK m̄yŋ`i AwaKvix nþZ nþe| tbZvþK A`g` Drmvin I DÍxcbv wbtq wbjm cwikŷ Kti thþZ nq| dtj ZvþK hþ_ó kviwi K I gvbumK k̄w̄i AwaKvix nþZ nq|

mweR`vq-`wqZj M̄þYi gvbumKZv

tKvb cŰZvþbi tbZZi.M̄þYi m̄f_ m̄f_ tbZvþK Gi `vq-`wqZj M̄þYI m̄þó nþZ nþe| cŰZvþbi mvgM̄K j`ŋ` ARþbi Rb` gj-Z tbZvB `vqx_vþKb| ZvB ejv nq th, tbZZi.I `wqZj GKB m̄f̄ M̄_Z| AZGe `wqZj e`wZtiþK tbZZi.nq bv|

ikŋv I mvgwRK Ae`vb

tbZvþK ikŋv nþZ nþe| Dchŷ ikŋv tbZvi gta` weþkŰY ŋlgZv, Avšhi KZvtera, Aa`emvq, AvZŷ mgvtj vPbv I AbywŰrmgbrv cŰwZ. ,þYi mgvtek NUvte| GQvon ikŋv tbZtZj Avi I AþK , Yveij weKvþki c_ m̄Mg Kti| mvgwRK w`K w`tq| tbZvþK Dchŷ gh̄vi AwaKvix nþZ nþe| tKbbv gvby mgvRe× Rxe| mvgwRK Ae`vb hv` tbZv m̄wK gh̄vi AwaKvix bv nb Zte Zwi cŰŋ| tbZZi.f`qv m̄æ nþe bv| ikŋv wefvMþK Gw`K w`tq AwaKzi mZK`nþZ nþe hvþZ thvM`Zg e`w̄MZ tbZZi.M̄þY KiþZ cviþeb|

ikŋv`vþbi thvM`Zv I ewM̄Zv

tbZvþK Zwi `wqZj cvj þbi Rb` AwaKvsk mgq msMVþbi tFZti I evBti weifbæ`tj i tjvþki m̄½ thvM`thvM KiþZ nq, Dfík` eŷtq tjvþK DŰy KiþZ nq| tm KviþY GKRb fvj tbZv GKRb fvj ikŋvI eþU| Aa`b`i cŰkŋY f`qvi Rb` tbZvi gta` ikŋv`vþbi thvM`Zv_vKv Avek`K|

gvbþq tbqvi gvbumKZv

Ae`vi m̄½ wbtRþK gvþtq tbevi gvbumKZv Mþo tZujv tbZvi Rb` Avek`Kix Ges tmUv weþkI Kti `w̄ wltq `Q aviyvi Dci wbfP Kti: (K) cwitek I msMVb m̄úþK`avi Yv I (L) gvbe Pwi Î Abgveb ŋlgZv|

(K) cwitek I msMVb m̄úþK`Q aviyvi: tbZvþK Zwi msMVb I cwitek m̄úþK` m̄yúó aviyvi ivLþZ nþe| GLvþb cwitek ejþZ m̄aviYZ msMVþbi cŰZwZ cŰv, c×wZ, KgPviþ`i a`vb-aviYv, Dfík` I b̄wZ BZ`w̄þK eŷvq| tbZvþK G mg`I Dcv`vb m̄úþK`cŰjvcv̄ I qv̄Kenvj nþZ nþe|

(L) gube Pwi Ā Abgreb ǃǃZv: msMVtb tbZv nt"Ob mKtj i tbZv| mǃZivs ĀfveZB
tbZvġK Zvi Abgrixġ i PwiĀ, cġKwZ, cQġ-AcQġ, Dġġk" I gjġeva BZ"w
m=utġKġ-ġQ aviYv _vġġZ nq| eĲZ tbZvġK Zui Abgrixġ i gb-gvbimKZv I
Pwiġġ K ġenkġvevj i wbiġġLB cwi Pwiġ Z KiġZ nq|

tgmbxq eĲZ,

GKRb tbZvġK ewj ō I tgmbxq eĲZġi AwāKvix ntZ nq| eĲZ eĲZġi ejġZ
AbġġK ekxfZ Kġi Avcb Dġġk" mrab Kwġġq tbqvi ǃǃZvġKB eǃvq| tbZvi
Avġġġxq eĲZġi KwġQ tġvawšZ Abgrixivl nvi tgġb hvq| ZvB tbZvi eĲZġi nġe
tmā-ggZv, Mvġġġ KZġ;wgġKZ wfbāġġc cwi ūwZ GKwU , Y|

**cġvmbK I
msMVġK ǃǃZv**

cġZġvġbi hveZxq Kvġġeij, m=ūĲ, hšġwZ BZ"wi ġġā h_vh_ mgZv wāvb,
KgPvixġ i ġġā thvMġġhM Ĳvcb Ges ĲwqZġ I KZġ" eĲġbi ġvāġġ msMVġġK
ġRviĲvi Kiv, hveZxq cwi Kġi bv cġġqb, Dġġk" wbaġġY I KgġZ tġvġġ i hveZxq
KgġġPġvi mǃZvġbqšĲ I ZĲviġKi ġvāġġ cġvmbK ĲǃZv I wĲZġxj Zv Avġqb
tbZvi AcwiġvġKZġ" | G aiġbi eūwā Kvġġeij m=ūvĲbi Rb" tbZvġK kwĲkijx
cġvmbK I msMVġK ǃǃZvi AwāKvix ntZ nġe|

mġi-cġvix Kġi bġkĲ

tbZv cġZġvġbi Rb" Dġġk" wbaġġY Kġib Ges Zv evĲvqġbi jġġ" cġġvRbxq
cwi Kġi bv cġġqb I KgġġP MġġY Kġib| G mKj Kvġġ m=ūvĲb mġi-cġvix
Kġi bġkĲ i cġġvRb nq| Ĳ K_vq, tbZvġK fġel rĲv ntZ nq|

thvMġġhM ġKŠġj

tbZv Zvi AwāKvix mgq eĲq Kġib msMVġbi wFZġi I evġġi msġġ cġZġvġbi mġ_
thvMġġhM mvaġb| tbZvġK cwi Kġi bv cġġqb, msMVb, wġĲRbv, tġġYv, mgšġmvab,
wġqšĲ cĲwZ. KvġġthvMġġhM Dci AZ"wāK wġġP KiġZ nq| ZvB Kx Dciġġ Ges
ġKvġġKvġġġKŠġġj tbZvi Dġġk" AwĲZ nġe Zv ZġġK DĲġiġġ RvġġZ I ešġZ nq|

**AvZġbqšĲ I
mshġkij Zv**

th ġKv Sġġ ev eĲ_Zvq tbZvġK wġPij Z bv ntq Ĳ cĲ"qm=ūbrāġZ nq| fveġġġM
Dġġġj Z nġqv Zui Rb" DvPZ bq| ZġġK Pig Ĳġġbi tgRvR VvŪv ivġġZ nq Ges
meĲv Avcb wPšĲi fveġġġK wġqšĲ KiġZ nq| eZġvġ AKZKvhZvq ĲahġaviY Kġi
ZġġK fivex epĲġ mvdġġ i Rb" ġwġġġ thġZ nġe|

wm=vs MġY ǃǃZv

MpxZ wm=vsġi DciB Kvġġġ KZKvhZv I eĲ_Zv AġġKvġġK wġġPġkij | tbZvġK
chġġġwġKfġte wm=vsġi wġġZ nq| Dġġk" evĲvqġb mrvqK wewfbāġġKġ cšĲ ZġġK
D"ġġeb KiġZ nq|

bĲvqci vqZv

tbZv nt"Ob Zui Abgrixġ i AbġġiġYi cĲxK| tm Rb" tbZvġK mr, bĲvqci vqY I
mZ"eZ ntZ nq| eĲZ tbZvi ġġā G mgĲĲ, Yveij i Afve Ĳġġ Abgrixġ i ġġā
wēġc cġZġġvqvi mġġ ntZ cġġi |

**mnġġwMZvgj K
qbbġxj Zv**

tbZvġK Abgrixġ i mġ_ mnġġwMZvi ġġbvġve wġġ KwR KiġZ nq| tbZvi
mnġġwMZvgj-K ġġbvēĲĲ Ĳġġ Zui Abgrixivl Zġġi ġġā Ĳxq mgġSvZv I
mnġġwMZv Mġġġ Zvġġġ | cĲĲšġġi, Zui ġġā mnġġwMZvi jġġY bv Ĳġġ Abgrixiv

Ktg® g nwiŋq tdtj Ges nZvk ntq cto| ZvB tbZvi mnthwMzvgj-K gtbveŷ
Aa`bt`i Rb`tcŰYvgj-K tKŠkj intmte KvR Kti|

mnmm I Df`vM

tbZvtK hveZxq KgRvtŰi cwí Kí bv cŰqb I ev`évqtb Df`vMx ntZ nq| fxiæ`fve
I`ŷ cKwZi tjvK tbZZ;cŰvth Aŋg| tbZvi mnmm I Df`vM Abgveŷb Abŷvixiv
mnmm cvq Ges Zvt`i gta` KvR Kivi cŰYZv ewx cvq| AZGe mvsMvubK Df`k`
ev`évqtbj j tŋ` tbZvtK meŋMŰmnmmKZvi mvt_ GwMtg AvntZ nq|

mgq mŋPZbZv

tbZvtK mwVK mgŋq mwVK mwvšÍ MhY I ev`évqb KiŋZ nq| wZwb mgŋqvcŋhvMx
mwvšÍ MhY bv Kiŋj cwí Yŋtg gviZK Ae`vi mwŋ nq| mgŋqi mŋ`envi KiŋZ bv
cviŋj i ayLiŋPi tevSvB evto bv eis Df`k` ARŰI e`vnZ nq|

fvimvg` iŋvi ŋgZv

tbZv wbtR eúnea Kvh®m`úv`b Kŋib Ges Aa`bt`i gva`tgI ZvtK weŋfbæKvR
m`úv`b KiŋZ nq| Dciš`GB Kvhŋgŋ GKwW AciwLi cwí ciK I ci`úí wbfŋkxj |
ZvB tbZvtK Zwi wbtRi I Aa`bt`i Kvthŋ gta` fvimvg` iŋv KiŋZ nq| fvimvg`
bwiZi Afvte cŰZōvth wek;Ljv t`Lv t`q| tm Rb` tbZvtK cŰZōvthi mwieŋ
Kvhŋej i gta` fvimvg` I mgZv iŋvq`ŋZvm`úv`bntZ nq|

bgbxq gtbvfe

tbZvtK`ŋq Kvthŋ ŋPšŋaviŋq bgbxq ntZ nq| Ae`vi cwí tŋŋŋŋZ ZvtK eúifcx ntZ
nq| cwí w`wZi mvt_ Zvj wŋwŋŋŋ Pjvi Rb` tbZvtK Aek`B Zvi cwí Kí bv, bwiZ,
mwvšÍ I Kvhŋej ŋZ bgbxq ntZ nq|

AbŷvŰrmgŷv

tbZvtK memgq AbŷvŰrmgŷv wbtq KvR KiŋZ nq| wZv`w`ŋbi hveZxq Kvhŋ NŰbvi
KviY I djvdj mšŋvšÍ wŋlqwi i e`vcŋti ZvtK tKŠZnjx ntZ nq| GŋZ tbZvi
Ávtbi cwí wa evto Ges wZwb cŰZōvthi wŋZŋti I evBŋti hveZxq wŋlq m`úv`K®
mŷúōfŋte I qwKenyj ntZ cvŋib|

mŋRbx cŰZfv

cŰZwbqZ MŋelYv I MVbgj-K mwbe`x ŋPšÍ kw³i Abŋxjŋbi gva`tg tbZvtK Zvi
mŋRbx cŰZfv wŋKvk mwab KiŋZ nq| ZvtK cwí Kí bv cŰqb, mwvšÍ MhY Ges Kvh®
m`úv`ŋbi bZb bZb tKŠkj I c`wZi Awie®vi KiŋZ nq hvi Rb` tbZvtK cŰli
mŋRbx kw³i Awakvi x ntZ nq|

Avšŋi KZvŋeva

fij tbZv Avšŋi KZv cŰkŋb Kvcŋ® Kŋib bv| tbZvi Avšŋi KZvŋeva t`ŋL Abŷvixiv
Avbw`Z nq Ges Zvi Avt`k wbtlaŋk hŋ_ō_iaZj mnKvŋi wetePbv Kti| tbZvi
Avšŋi KZv`vKŋj wZwb Aa`bt`i Űviv AŋbK KwWb KvRI Kwíŋŋ wbtZ cvŋib|

**Aŋb`i gZvgŋZi cŰZ
k`vkvxj Zv**

me®v GKZi dvŋŋte`ŋq gZvgŋZŋK cŰavb` t`qv fij tbZvi j ŋŋY bŋn| ZvtK hveZxq
iaZŋŋŋŋŋŋŋ m`úv`K®Abŷvixiv`i mvt Avjvc AvŋjvPbv KiŋZ nq Ges gZvgZ MhY
KiŋZ nq| Zŋe wZwb m`e ntj Zvt`i gZvgZ MhY KiŋZ cvŋib, Avi m`e bv ntj
D³ gZvgŋZi cŰZ h_vh_ k`v cŰkŋb ceŋ Gwŋŋŋl thŋZ cvŋib|

mvavi Y Ávb

tbZvᄃK eüglyx Kvhᄃmᄃúv`b KitZ nq Ges mnKgxᄃ i wefbaecᄃkie mᄃšl RbK DĒi wᄃZ nq| GB eümea Pᄃvtj Á tgvKvᄃejv Kivi Rb` ZᄃK ivóbᄃwZ, A_ᄃwZ, mgvRbᄃwZ Ges Ab`vb` eü weᄃtq hᄃ_ó Ávᄃbi AwaKvix nᄃZ nq| msMVᄃbi mdj Zvi Rb` thgb tbZv meᄃaK cᄃksᄃwZ nb ᄃZgᄃb Zvi e`_Zvi Rb`I gj-Z wZᄃB `vqx nb| ZvB ZᄃK weᄃkl Á bv nᄃq eis eü weᄃtq cvi 1/2g nᄃZ nq|

Aa`vemvq

GKRb mdj tbZvi Ab`Zg weᄃkl ,Y nᄃ`Q Aa`vemvq| ZᄃK ᄃᄃAa`vemvqB tmšfvᄃM`i cᄃwZᄃᄃ G bᄃwZi Abyvix nᄃZ nq| fvi tbZvᄃK `ᄃq KgᄃᄃPᄃv ev `jxq Kvhᄃmᄃúv`ᄃbi tKvibjc mivgᄃqK e`_Zvq nZvᄃb bv nᄃq cieZvᄃepr I PᄃvšI weRᄃqi Rb` wᄃbij m KivR KitZ nq| AwaKš`wZᄃb e`_Zv nᄃZi dj cᄃ wᄃᄃv MᄃY Kᄃi _vᄃK|

AvZᄃmgvᄃj vPbv

ᄃᄃZv I KZᄃZi tgvᄃn tbZvi cᄃᄃ AevᄃZ ev AcᄃZKi e`e`v MᄃY Kiv ev KgᄃᄃP nᄃZ tbqv wePᄃ bᄃn| ZᄃK cᄃZᄃbqZ AvZᄃmgvᄃj vPbv KitZ nq| ZvᄃK meᄃv KZKgᄃ I cᄃvZ wᄃvᄃšl cᄃlvbgyL gj`vqb KitZ nq Ges cᄃAvcYᄃePvi weᄃk- IYceR `ᄃq Kᄃᄃᄃ I gᄃbvᄃvᄃei i`e`j NUVᄃZ nq| Gwᄃ tbZvi GKwᄃ AZxe ,iᄃZcYᄃ, Y|

mweR avi Yv

tbZv GKwᄃ wᄃᄃᄃᄃ KivR Kᄃi| A_P GB wᄃᄃᄃᄃ gᄃwᄃ AmsL` Dcv`vb I weᄃg Ae`v ᄃvᄃv cᄃvweZ nq| tbZvᄃK G Dcv`vb ,wᄃ i cᄃZ`KwᄃᄃK wfbwᄃvᄃvᄃvᄃe wePvi bv Kᄃi eis Gᄃi mᄃvᄃj Z cYᄃᄃ wᄃᄃᄃᄃ mᄃᄃᄃᄃ wᄃšl KitZ nq, KviY G ,wᄃ ci`üi wᄃfᄃkxj |

weᄃk- IYgj K ᄃᄃZv

tbZvᄃK mKj cᄃwᄃZK weᄃqmgᄃ Zvᄃ Abyvix MᄃK weᄃkᄃ Y Kᄃi evᄃᄃq wᄃZ nq| msᄃwᄃ weᄃq I NUBvewj i KviY I djvdj wᄃᄃq ZᄃK wᄃšlᄃvᄃv I Mᄃel Yv Pvj vᄃZ nq Ges Zvi Abyvix`iᄃK G ,ᄃjv mnR, mij I cᄃÁj fvlvq e`vL`v Kᄃi wᄃZ nq|

eÜzcᄃZgZv

tbZv Zvᄃ Abyvix`i Rb` tKej üKg`vZvB bᄃnb eis GKRb weᄃk`leÜz etU| ZᄃK eÜmᄃjᄃ e`envi I AvPiY ᄃvᄃv Abyvix`i Ašl Rq KitZ nq| Zᄃi mᄃL `ᄃL ZᄃK Zvᄃi cᄃᄃk wᄃᄃq `wᄃᄃZ nq|

wePvi weᄃePbvᄃ ᄃᄃZv

tbZvᄃK cᄃi wePvi kwᄃᄃmᄃúvᄃeᄃZ nq| wePvi weᄃeKᄃxb ᄃjvKᄃK Aa`ᄃbiv tbZv etj MᄃY Kᄃi bv| tbZv `ᄃq weᄃeK cᄃᄃwᄃ Kᄃi DĒg KvᄃᄃP Rb` KgᄃᄃYᄃK cy`Z.Kiteb Ges g` KvᄃRi Rb` mᄃᄃkvaᄃbi cᄃᄃvRbᄃq cšv ev Dcvq wᄃᄃ`R Kiteb; tKvb Ae`ᄃZB fvj I g`ᄃK mgᄃvᄃe MᄃY Kiteb bv|

ekxfZKiY kwᄃᄃ

tbZvᄃK `ᄃq Dᄃi`k` I msMVᄃbK Dᄃi`k` nᄃwᄃᄃj i jᄃᄃᄃ Ab`vb`ᄃiᄃK etk AvbᄃZ nq Ges wᄃᄃRi a`vb aviYvi mᄃᄃ_ Zᄃi a`vb aviYv AwᄃfZ KitZ nq| G Rb` ZᄃK msᄃwᄃ mKᄃj i gb`wᄃEK w`K Abᄃvᄃeb KiZ mᄃwK tKšKᄃj i gvaᄃᄃ Zᄃi ekxfZ KitZ nq|

cᄃZcᄃᄃᄃ tbZZj.gbbkxj ,Yvevj i mgwᄃ| wefbaecwᄃw`wZᄃZ wefbae ,Yvevj i cᄃᄃvRb nq| Zᄃe tKvb e`wᄃᄃi gᄃa` Dctivᄃ ,Yvevj i mgvᄃek NUᄃj ZvᄃK tbZv ejv hvq| wᄃš` tKn tKn Dctivᄃ ,Yvevj i gᄃa` gvᄃ KᄃqKwᄃ ,ᄃYi AwaKvix nᄃqI mdj tbZᄃZj cᄃwPq wᄃᄃᄃQb| Avevi AᄃᄃKᄃi gᄃa`B Gᄃi AwaKvix ,Yvevj _vKv mᄃĒj Zviv tbZZj. cᄃvᄃb e`_ᄃnᄃᄃQb| Zᄃe cᄃwᄃek I Kvhᄃcᄃwᄃw`wZi `ᄃᄃ chᄃeᄃY, mnbkxj Zv, cᄃivcKwᄃ Zv, wePᄃYZv I MYZwᄃšKZv BZ`w` e`wᄃᄃᄃK tbZᄃZj `ᄃZv ARᄃb mnvqZv Kᄃi _vᄃK|



cv#VvEi gj`vqb 7.5

A) ms#f#B DvEi c#kæ

1. tbZvi #k#f#Z nl qv c#qvRb tKb?
2. tbZvi Kx ai#bi c#k#m#bK l m#s#M#v#bK `f#Zv _vKv c#qvRb?
3. tbZv#K tKb f#el`r `#v n#Z nq?
4. tbZvi t#f#f# AvZ#-#bq#Y l mshgk#j Zvi c#qvR#b#q#Zv Kx?
5. tbZv h#` b`vqci#qY bv nb Zvnt#j Kx Am#e#avi m#o n#Z cv#i?
6. AvZ#-#gv#t#j vPbv tbZvi GK#U AvZ c#qvR#b#q# _Y tKb D#j # Ki#b#|
7. tbZvi mn#h#v#M#Zv mnK#x# i g#t#` Kx ai#bi Ab#v#Z m#o K#i?

Av) iPbv#j-K c#kæ

1. Av#b#K tbZvi _Y#v#j i nek` #eeiY #`b#|



Pov#f#gj`vqb 7

A) ms#f#B DvEi c#kæ

1. tbZ#Z#j A_#Kx?
2. mbvZb tbZ#Z#j avi Yvi tK#`#q #el q tKv#b#U?
3. tbZ#Z#j GK#U m#v#v#R#K `f#Zv - m#s#f#t#c e`vL`v Ki#b#|
4. msj #f#Y#j#-K tbZ#Z#j i #v#Zi `e#k#o` Kx?
5. M#Y#Z#v#S#K tbZ#Z#j `#f#c Av#t#j vPbv Ki#b#|
6. #d#W#j v#i i g#Z tbZ#Z#j K#Z c#k#vi l Kx Kx?
7. tbZv #be#P#t#bi _i#z#j e`vL`v Ki#b#|
8. G`v#U#v#P#t#g#U l t#U#j vi t#g#B#W tKv#t#m#P g#v#`g #K#f#r#t#e tbZ#Z#j #e#K#v#k Ki#v h#q?
9. tbZvi #k#f#Z nl qv c#qvRb tKb?
10. tbZv h#` b`vqci#qY bv nb Zvnt#j Kx Am#e#avi m#o n#Z cv#i?
11. AvZ#-#gv#t#j vPbv tbZvi Ac#v#i n#v#h#` _Y tKb?
12. tbZvi D#v#e#b#x f#v#g#K#v _t#j v D#j # Ki#b#|

Av) iPbv#j-K c#kæ

1. tbZ#Z#j mbvZb l Av#b#K av#v Av#t#j vPbv Ki#b#| #k#f#v K#v#f#g e`e`v#c#b#q tbZ#Z#j _i#z#j e`vL`v Ki#b#|
2. tbZ#Z#j #g#v#e#K#v#f#v#E#K i #v#Z# _t#j v #ee#Z Ki#b#|
3. eisj v`#k#i #k#f#v e`e`v#q tbZv #be#P#t#bi tK#S#k#j _t#j v Av#t#j vPbv Ki#b#|
4. tbZ#Z#j m#v#i Y K#v#f#e#j #ee#Z Ki#b#|
5. Av#c#v#i `#o#t#Z Av#b#K tbZvi `k#U c#v#b _Y#v#j i #eeiY #`b#|

cW 8.1

Dvgŷ wLb I `i-wŷvi aviYv

[Ideas of Open Learning and Distance Education]

Df`ik`

GB cW tkfI Avcw –

- `i-wŷvi aviYv e`vL`v Ki`Z cvi`eb;
- `i-wŷvi wefbaet`tk wefbaetv`g cwiwPZ Zv ej`Z cvi`eb;
- `i-wŷvi KtqKuU msAv ej`Z cvi`eb;
- Dvgŷ wLb Kx Zv ej`Z cvi`eb;
- Dvgŷ wLtbI KwŷŷZ j`ŷ` Df`L Ki`Z cvi`eb;
- Dvgŷ wLtb wLb mvgMbi` fvgKv eYŷv Ki`Z cvi`eb;
- Dvgŷ wLtbI `ewkó` Df`L Ki`Z cvi`eb Ges
- tKgb Kfi Dvgŷ wLtb mnvqZv cŷvb Kiv nq Zv ej`Z cvi`eb/

`i-wLb ASZ cAvk ermi cte`iia` ntl mrvúŷZKKvtj Gi m`úthviY Dfj-LthvM`| GB wLtb wŷv_x`wŷŷK t`_tK eú`fi Ae`vb KfiI wLb-tkLv`bv Kihŷg AvtqvRb I cwiPvj bv Kvtj ev cti AvaybK thvMvthvM gva`tg ubRtK m`úŷ` Ki`Z cvi`eb/ `i-wLb e`e`v n`Z eúj vstK c`K Dvgŷ wŷv e`e`v hv A`bK cti c`hvi jvf Kfi`Q| GuU c`Zŷbi Df`ik` nj, th me wŷv M`hY`Qy`wŷŷv_x`mvgvRK ubq`gi Kf`vi Zv, A`ŷwZK, cwiwvi K I tckvMZ KvifY c`ŷj Z wŷv e`e`vq wŷv`jv vf Ki`Z cvi`Q bv ev Bw`úZ wŷv t`ŷM`g mgvB Ki`Z e`_`n`ŷ`Q wKsev ŌRxebe`v`cx wŷv`ŷi m`hvm M`hY AvM`h tm me wŷv_x`ŷK `^`^Ae`v`b t`_tK wŷv jvf`fi m`hvm`v`bi e`e`v Kiv|

Dvgŷ wŷv e`e`vq wŷv jvf th me Dcv`g msMvZ n`q`_v`K Zv nj`i`b, t`_tL, t`_tL I`i`b (wUvf, wfiwI) Ges cto (gvy`Z cv`c`y`K)| GQov uba`ŷi Z I m`xgZ mg`g LŪKvjxb wDUi`i`f`cx wŷv`ŷKi Avtj vPbv Kw`m thvM`vb KfiI t`kLv hvq| GQov AvaybK c`h`ŷ`i gva`tgI G ai`bi wŷv cwiPvj Z n`Z cvi`eb|

`i-wŷvi Kx?

`i-wŷv GK ai`bi wŷv`vb tKŷkj hvi gva`tg wŷv_x`wŷŷv cŷZŷvb/wŷŷK t`_tK eú`fi Ae`vb KfiI wŷv M`hY Ki`Z cvi`eb| `i-wŷvi` ŷ`ŷ` tgŷŷj K Dcv`vb i`q`Q: (1) wŷv_x`wŷŷK t`_tK eú`fi Ae`vb Kfi, (2) `i-wŷvq wŷv`ŷKi fvgKv c`ŷj Z ev cŷvMZ wŷv`vb t`_tK wfb`e`ai`bi nq| thgb- evsj v`k Dvgŷ wekte`ij`ŷ`qi wefbaet`Ab`ŷ`i gj- wŷv`KMY GL`bv wŷv_x`ŷ mvg`b L`ŷ GKUv Dcv`Z nb bv; eis weKf e`e`v wnt`m`te wŷv_x`ŷK cigv`k`v`ŷbi Df`i`ŷ`k` wDUi`wvi`qvj Kw`m`f` mg`g`i`Rb` LŪKvjxb wDUi`e`v` wŷv_x`ŷ g`ŷ`L`v`g`y` nb| G Rv`Z`x`q wŷv e`e`vq gvy`Z wLb

(M) `i- ukŷv GK ai#bi ukŷY (Teaching) c×wZ hv#Z ukŷK (gj- ukŷK Ges tKvmŷPwqZvMY) eŷ `#i Ae`vb K#iI c#eŷiKWŷZ. ukLb mvqMŷ I ukLb c`v#K#Ri gva`tg ukŷv_x#K `^ukLb Kv#R mnvqZv K#i _v#Kb| ukŷv_x#Dcwij mLZ `B c#Kv#i i ukŷK t_#K mgq I `v#bi (Time and Space) w K w`tq `#i Ae`vb K#iI ukŷv msµvšÍ cŷŷqvRbxq wbt`Rbv t#tq _v#Kb| (Distance learning is a learning while at a distance from one's teachers usually guide students with the help of pre-recorded, packaged learning materials. The learners are separated from their teachers in time and space but are still being guided by them).

`i- ukŷv thvM#thvMi gva`g

wŷgŷx thvM#thvMi

`i- ukŷv thvM#thvMi cŷµvq wŷgŷx A_ŷ cŷZŷvb cŷvb e`e`vcbvi `wq#Z; wbtqwiRZ wefv#Mi KgŷZŷMY#K cŷZŷv#bi bwiZ m#ú#KŷAewZ Ki#eb| Aciw`#K e`e`vcvi `wq#Z; wbtqwiRZ wefvM ukŷv_x#P i#K ev`bvq#bi Dcvq AewZ Ki#e I Kv#Ri mnvqZv cŷvb Ki#e| Kv#Ri mnvqZv `v#bi Rb` wbt#ŷ³ Kv#Rm#ú#b#Ki#Z n#e| thgb- gvV ch#qi KgŷZŷ#K wbcwqZ cŷKŷ#Yi gva`tg Avc#wUKiY, cŷmw#K `wjjcÍ t#ŷY, wbt`Rbv I Drmiv cŷvb, wbcwqZ gj`vqb mfv Av#qvRb, wbcwqZ Z_`cÍ (News Letter) t#ŷY, mgv#Ri m`m#`i m#½ mfv mwqWZ K#i Dvgŷ ukL#bi j`ŷ`j I msukŷ mKj#K AewZKiY I mnvqZvi e`e`v Kiv n#q _v#K G c×wZ#Z|

Dvgŷ ukLb K#?

- Dvgŷ ukLb nj cŷw#Z Avbŷw#K ukŷvi eva`evaKZv n#Z gŷ t_#K ukŷv Mŷ#Yi GKw e`e`v|
- Dvgŷ ukLb nj GKw `kŷ I ukLb-ukLv#bvi KZK_#jv c×wZi mgvšZ ukLb e`e`v|

Dvgŷ ukL#bi j`ŷ`ŷ

Dvgŷ ukL#bi KZ_#jv meRbx wŷw`ŷ j`ŷ`ŷ (Aims) i#t#Q| tm_#jv wbtP Dc`vcb Kiv nj :

- ukŷv_x#P ukŷv jv#fi D#i#k`i Dci_#i#Z; cŷvb Kiv nq weavq ukL#bi avcmg# AZ`š#wŷw`ŷ ŷfv#e Dc`vcb K#i ukŷv_x#K mnvqZv Kiv nq|
- ukŷv_x#P wR cw#ek I Avf#Zv (Mn, mgvR, m#ú#vq, Kgŷŷŷ BZ`w`) h_vh_ I wŷw`ŷ ŷfv#e wPw#Z K#i ukLb w#lqe`Ašf#ŷ Kiv nq|
- ukŷv_x#P`^`k#b Zvi ukLb Kv#Rcw#Pw#Z K#i _v#K, ZvB cŷZ`#Ki ukL#bi ai#bi cŷZ k#v cŷkŷ Kiv nq| Gifc ukL#b e`w³ mgMŷM#Ev#K m#ú#³ K#i _v#K| tm Kiv#Y Gw K_#jv#K h#_ŷ_#i#Z;#` I qv nq|
- `Zš;I `v#b#v#e Avb#R#b ukŷv_x#K mnvqZv Kivi A#xKvi Dvgŷ ukŷv w#wŷZ K#i|



ciſVvĒi gj`iqb 8.1

A) mſiſB DĒi cĕæ

1. `i-ſkſvi tgſij K Dci`vb KqſU I Kx Kx ?
2. Dɔgʃ ſkLb Kx Kx Dciſq mſMſZ nq ?
3. `i-ſkſvi bgbxqZvi AvI ZvſZ Dci`vb Kx Kx ?
4. `i-ſkſvi GKſU mſAv ij Lſj|
5. Dɔgʃ ſkLb Kx ?
6. Dɔgʃ ſkLſbi `ſj c`K ſi`K Kx ?
7. Dɔgʃ ſkLſb ſkLb mvgMſi KſR Kx Kx ?
8. `i-ſkſvi I Dɔgʃ ſkLſbi ci`R` ij Lſj ?

Av) iPbvj-K cĕæ

1. `i-ſkſvi avi Yv e`vL`v Kiab|
2. Dɔgʃ ſkLſbi j ſj I `eiſkſ` ſeeZ Kiab|

cW 8.2

„YMZgub : avi Yv, msÁv, msi ħĦY chĦq I ibwĠZKiY %enkó”

[Quality Assurance: Concept, Definition and Ensuring Status of Preservation]

Dġġk”

GB cW tkġI Avġwb –

- „YMZgubġbi avi Yv eġvLġv KiġZ cviġeb ;
- „YMZgubġbi KġqKġw msÁv Dġġ ħ KiġZ cviġeb;
- „YMZgub msi ħĦYi chĦqmgġ weZ KiġZ cviġeb Ges
- „YMZgub ibwĠZKiġYi ġenkó” eYĠv KiġZ cviġeb|

„YMZgubġbi tgġġj K avi Yv

MZ ġ kZvāeġvcx ġkĦĦvi gub (standard) wġq eġ Avġ vc Avġj vPbv I weZKġntġqġ| eZġġb GB Avġj vPbv standard tġġK cwiwZġ ntġ „YMZ wġK ev quality- tZ GġmġQ| Zv ntġ „Y ev quality ejġZ Avġiv Kx eġe? Avġiv mwavi Yfġte hv eġs Zv nj tKvb eġ ev wġġġi wKQyġenkó” hv tġvġvi ev eġeniKvixi cġġvkv cġY KiġZ mgġnq| tgġġvKġvq „Y nj tġvġvi mġġġ (quality is the satisfaction of the client)| „Y mġġxq weZġKġ mgwġġZ wmwġġ MġxZ nq th, „Y nj ġġZ.gvb Ges Pig DrKġIġ mgvġġ| „ġYi Aci GKġw ġenkó” nj ġġZ.gvbġK ibwĠZKiY| Avi ġġZ.gvb ev standard nj „Y cwi gġci wġġġ| GB Avġj vPbv tġġK Avġiv ejġZ cwi th, „Y nj gġmġġġ GKġw avi Yv hvi gġa” fij I wġġġ gġwġenkó wġK iġġġQ|

„YMZgub ejġZ Kx eġġq?”

ġkĦĦweġ tWvrvġ(Doherty)-Gi gġZ „Y nj gġmġġ GKġw cġ hvi gġa” wġlq tKwġK fij I wġġġ gġwġenkó wġK mġġġ iġġġQ| (Quality is a value laden term meaning its subjectivity associated with that which is good and worth while.)

wġ Avi ivgubġvġ Gi gġZ- ġkĦĦvi fġvġq ōġ, Yġġ ejġZ ġkĦĦv cġġvq (processes) Ges Drġvġ (products) Gi ġġZ.gvb (standard) Ges Pig DrKġIġ(excellence) -tK mwavi Yfġte eġġġvġK|

(Quality is a term commonly understood in the academic word as ‘standard’ and ‘excellence’ of the processes as well as the products.)

MġY (1994) „YMZ gubġK tġKġvġ vi MġYi wġwġeġcġġvġġU wġgġġc msÁvġqZ KġiġQb -

- wġġġeġġġq: RvZxq ġġZgubmġġeġ ġkĦĦvġġb Kx Abyġ mġmġeġ hġvġ thvMġZmġġeġ
- tġkv: tġkvMZ ġġZv mġġġU Abyġ mġmġMY Kx tKvb ġġZ.cġZōvb tġġK mbġcġġ?
- wġġġMġvbKvix: wġwġeġġġ ġkĦĦvġġPv Kx Kgġġġġġ ġġZvi mġġġi ivLġZ cviġQ ?

- AiwffveK I ukŷv_x© AiwRZ ukŷvK ukŷv_x©I AiwffveKMY Kx h_v_©gj` w`tq _v`Kb?

në(Holt)-Gi gŷZ cŷZŷvbi cŷZ`KŷK mŷuqfviŷe nŷZ-Kjtg ukŷLtg Kŷg©
 wbtqmwRZ Kivi gZ`ŷ I Av`kŷkŷvB nj ŷ Ym=úbankŷv|

Dvgŷ ukLb I `i-ukŷvi ŷ YMZgub msiŷŷYi chŷq

Dvgŷ I `i-ukLbŷi ŷ YMZ gub msiŷŷYi `w chŷq itqŷQ| GB chŷq `w nj :
 tcŷŷvCU m=úxq chŷq (contextual) Ges Kvhŷŷgi mŷúó mŷgŷiLv m=úxq chŷq
 (definitional aspects)|

Dvgŷ I `i-ukLbŷi tcŷŷvCU m=úxq chŷqi gŷa` itqŷQ, (K) gŷbe m=ú` m=úxq
 w`K Ges (L) tŷŷZ mŷhvm-mŷeav mŷukŷ w`K| GQvov Kvhŷŷgi mŷúó mŷgŷiLv mŷukŷ
 KŷgŷKw w`K itqŷQ hv ŷ YMZgub msiŷŷYi Rb` Acwi nŷhŷ wbtP GmKj w`K mŷŷŷŷc
 DŷjL Kiv nj |

1| tcŷŷvCU m=úxq chŷq

(K) gŷbe m=ú` mŷukŷ w`K (Human Resources)

- ŷ YMZ gŷŷbi bŷwZ cŷŷqbKviŷ (Quality of policy makers)
- ŷ YMZ e`e`vcbv (Quality of management)
- ŷ Ym=úbwGKŷŷwŷgK ÷vd (Quality of academic staff)
- ŷ Ym=úbamŷvqZv ÷vd (Quality of support staff)
- ŷ Ym=úbankŷv_x©(Quality of students)

(L) tŷŷZ mŷeavmŷukŷ w`K (Physical Resources)

tŷŷZ mŷeavmŷukŷ m=úŷ`i gŷa` itqŷQ -

- chŷŷ AwL`R mŷeav (evŷRU eivI)
- chŷŷ RvqMv Rŷg
- chŷŷ / cŷŷqŷRbŷq Ni ewio
- chŷŷ hŷŷcŷwZ

2| Kvhŷŷgi mŷúó mŷgŷiLv m=úxq chŷq

- ŷ YMZ gŷŷbi tcŷŷMŷg I tKvmŷŷgŷ
- ŷ YMZ gŷbm=úbaweziv e`e`v
- ŷ YMZ gŷbm=úbamŷvqZv tmevi e`e`v
- ŷ YMZ gŷbm=úbawej`vqb Kvhŷŷg
- e`ŷqi Kvhŷŷwi Zv (cost effectiveness)



ciVvEi gj`iqb 8.2

A) msi`B DEi ckae

1. , YMZgvb ej tZ Kx eSvq?
2. 00, Y00 iKifc avi Yv|
3. tWwvU°, YMZgvb ej tZ Kx eStqtQb?
4. i vgvbRig Gi gtZ , YMZgvtbi Dcv`vb Kx Kx?
5. M0Y t÷ Ktnvi vi MtYi Pwn`vi tciqtZ , YtK Kx Kx cUfugtZ Dc`vcb Kti tQb?
6. Dvg` I `i iKLtbi , YMZgvb msi`qtYi chiq Kqu I Kx Kx?
7. Dvg` iKLb I `i iKqvi gvbe m`u` msuk0 i` K, tj v Dtj i Kiab|
8. Kihfctgi myu0 migtiti Lv m`Uxq chiqi AvI ZvfZ Dcv`vb Kx Kx?

Av) iPbvj-K ckae

1. , YMZgvtbi avi Yv e`vL`v Kiab|
2. , YMZgvtbi KtqKuU msAv Dtj i Kiab Ges tKvb msAv `enkogUz hyB mnKviti ij Lb|
3. Dvg` iKLb I `i iKqvi , YMZgvb msi`qtYi chiq Avtj vPbv Kiab|
4. , YMZgvb i bwiZKi Y Kx Zv D`vni Ymn e`vL`v Kiab|

civ'mip

„YMZgvtbi ukŕiv`vtbi Rb` GKuU Avc-UztWU civ'mipi GKvšl cŕqvRb| Gifc civ'mipi ZvEĶ I e`enwiK w`tki gta` GKuU mvgÄm`cY`Fvimvg` iŕivi e`e`v` _vKtZ nq Ges Dfŕq w`tki Kvh`h_vmgtq m`ubk`iŕyi Rb` mŕztK`Yx iaUb cŕqb I AbyiY KtZ nq|

ukLb civigvc e`e`v`

ukŕiv`xP ukLb AMMwZ (ZvEĶ I e`enwiK) civigvtci Rb` GKuU mŕzl cŕqMthvM` e`e`v`_vKtZ nq| civigvc Kvh`ŕg avivevnKfvte cŕqv`Mi Rb` GKuU w`t÷g Mto ZŕtZ nq thb e`w`3 Aŕcŕiv w`t÷g tew Kvh`Rix nq| ukŕivi „YMZ gvb msiŕiv I ew`xi Rb` ukLb civigvc Acwi nvh`

„YMZgvb wePvfi cŕZŕvbi`vb

wetk`i cŕq mKj t`tkB ukŕiv cŕZŕvbi gvb w`bifcŕyi Rb` KZK`_tjv gvb`Ü`_vŕK| D`3 gvb`ŕÜi civigvtc msukÜó cŕZŕvbiU tKvb tM`Wi Ges tKvb`_vŕb Ae`vb KtŕZ Zv Rvbr hvq| ukŕivi „YMZ w`K w`bifcŕY cŕZŕvbi Ae`vbl m`uŕq wetep` w`K w`tmtē MY` Kiv nq|

`i`ukLŕbi „YMZ gvb w`bwiŕZKiŕY KtqKiu mgKvjxb tKŠkj

mgKvtj ukŕivi „YMZgvb w`bwiŕZKiŕyi Rb` KZ`_tjv tKŠkj D`m`eb Kiv nŕqŕQ| GB tKŠkj`_tjvi gta` w`ZbiU euj civiPZ| thgb- (1) avivevnK cŕuqvwfivEĶ tKŠkj, (2) `vkŕK gj`tevwfivEĶ tKŠkj I (3) ukLb Dŕiŕk`i tK`YwefvMwfvEĶ tKŠkj | Dvgŕ ukLb I `i`ukŕiv`yi tŕŕŕ G`_tjv Abyiŕyi gva`tg „YMZgvb w`bwiŕZKiY m`e`|

(1) avivevnK cŕuqvwfivEĶ tKŠkj

ukŕivi „YMZgvb w`bwiŕZKiŕyi Rb` mgKvtji ukŕivwe`MY avivevnK cŕuqvwfivEĶ tKŠkj i AvI Zvq thme Kvh`m`ur`b Kŕi _vŕKb tm`_tjv nj :

avivevnK cŕuqvw AbyZe` avcmgn`

- civ`uŕg Kivv`tgv (course structure) w`baŕY
- tKvm`cŕ`ZKiY (course preparation)
- ukŕivi AMMwZ civigvc Afvŕiv (developmental testing) cŕqb
- `i`ukLb ev`evqb ciweŕiv (monitoring of distance education transaction) Kvh`ŕg
- Avŕi w`cZ Kvh`cwi Pvj bv (assignment handling)
- ukŕiv`xP mrvqZv tmev (student support services) Kvh`ŕg
- gj`vqb (evaluation) e`e`v`|

`i`ukLŕbi „YMZgvb w`bwiŕZKiŕY Dcŕi ew`ŕ mivZiU avŕci Kvh`tjv avivevnKfvte GKiu cŕuqviv gva`tg h_vmgtq m`wK fvte m`ubbeKiv nŕj ukŕivi „YMZ gvb ARŕ w`bwiŕZ Kiv m`e`, GK_v ukŕivwe`MY AZ`šl`pZvi mŕt`_eŕj _vŕKb|

(2) ᄡkᄡK gj-ᄡevawfiĒK tKŠkj

ᄡkᄡK gj-ᄡevawfiĒK tKŠkji gᄡa iᄡqᄡQ mveRbxbZv, hvi gvaᄡg MYZmŠK Awakvi cĀZiōZ nq, ᄡkᄡv eē-ᄡq Gi BwZeiPK cᄡve cᄡo, cĀᄡᄡkᄡq cĀmᄡKZv Avbqb Kᄡi MᄡYᄡhvMᄡZvi gvᄡv evovq, cwi Yᄡg bZᄡ bZᄡ Avb mᄡo nq| ᄡkᄡK gj-ᄡevawfiĒK tKŠkj ᄡjv nj :

gj-ᄡevawfiĒK tKŠkj

- mᄡhvM l mgZv (Access and equity)
- ᄡkᄡv eē-ᄡi Dci cᄡve (Impact on educational system)
- cĀᄡᄡkᄡ, cĀqvRbxbZvi cĀmᄡKZv (Relevance, expectations, needs)
- MᄡYᄡhvMᄡZv (Acceptability)
- Ávᄡbi Dᄡe (Generation of knowledge)

Dcᄡi ewYᄡ tKŠkj ᄡjv Aeᄡᄡb ᄡkᄡv Kvhᄡg ev-ᄡmᄡZ nᄡj ᄡkᄡvi ᄡMZ gvᄡ ᄡbᄡZKiy mᄡeci nᄡe etj ᄡkᄡve MY gšē Kᄡiᄡob|

(3) ᄡkLb Dᄡiᄡkᄡi tKᄡvefMfiĒK tKŠkj

ᄡkᄡvi ᄡMZ gvᄡ ᄡbᄡZKiy ᄡkLb mᄡᄡᄡq Dᄡiᄡkᄡi ᄡᄡkᄡ cᄡve ᄡē-ᄡi Kᄡi ᄡᄡK| ᄡkᄡv mᄡᄡᄡq Dᄡiᄡkᄡi cᄡve Kx tm ᄡelᄡq AvᄡvPbvi cᄡeᄡᄡkᄡv mᄡᄡᄡq Dᄡiᄡkᄡi Dᄡᄡᄡᄡbi cUᄡᄡg l Zvi tKᄡvefM mᄡᄡᄡKᄡᄡᄡᄡK avi Yv ᄡ l qv nj :

ᄡkLb Dᄡiᄡkᄡi tKᄡvefM

ᄡēAvbᄡ tebRmᄡᄡ egᄡ RxeᄡēAvᄡb eē-ᄡᄡZ Taxonomy ᄡkᄡvᄡᄡᄡᄡ eē-ᄡvvi Kivi GKwU ᄡeivU mᄡhvM mᄡo Kᄡi ᄡᄡqᄡob| eZᄡᄡᄡ ᄡᄡkᄡ ᄡkᄡvᄡᄡᄡ cĀYZvMY eᄡᄡi Taxonomy Abᄡiy Kᄡi ᄡkᄡvi Dᄡiᄡkᄡi tKᄡvefM Kᄡi ᄡᄡKb| eᄡᄡi Taxonomy-tZ AvPivYK fivᄡq Dᄡiᄡkᄡi cĀKvK Kiv nq| ᄡZᄡb cĀgZ Dᄡiᄡkᄡi ᄡjᄡK ᄡZb fivM fivM Kᄡiᄡob| thgb -

- Ávᄡ mᄡᄡᄡq Dᄡiᄡkᄡi (Cognitive)
- AbᄡvZᄡᄡ-K Dᄡiᄡkᄡi (Affective)
- gᄡbᄡᄡckvR Dᄡiᄡkᄡi (Psychomotor)

egᄡ-Gi Dᄡiᄡkᄡi tKᄡvefMᄡK Domains of Educational Objectives eᄡv nᄡq ᄡᄡK|

Ávᄡ mᄡᄡᄡq Dᄡiᄡkᄡi

Ávᄡ, gvᄡᄡK ᄡᄡZv l Zvi cĀqvM, gj-ᄡvb BZᄡᄡᄡK Ávᄡ ᄡelqK Dᄡiᄡkᄡi eᄡv nq| GB Ávᄡ ᄡelqK DᄡiᄡkᄡiᄡK QqfivM fivM Kiv nᄡqᄡQ| Gᄡ ᄡjv nj :

(1) Ávᄡ, (2) Abᄡveb, (3) cĀqvM, (4) ᄡᄡkᄡY, (5) mᄡkᄡY Ges (6) gj-ᄡvb| Ávᄡ mᄡᄡᄡq Gme Dᄡiᄡkᄡi cᄡivcᄡv fivᄡe Rvᄡv ᄡKᄡj th tKvᄡ ᄡelq mᄡᄡᄡKᄡmᄡᄡᄡK avi Yv ᄡvᄡf Kiv Ges Kivᄡᄡᄡᄡ ᄡb Zv KivRi fivᄡe eē-ᄡvvi Kiv hvᄡ|

Abfuzgj-K Df'ik"

tKvb ielq MhY I eRb, cQ` AcQ`, Abfuz Ges AvtetMi gvIv BZ`w`
Abfuzgj-K Df'ik'i AšMZ| Abfuzgj-K Df'ik`k cBwU tkYxtZ ief³ Kiv
ntqtQ| thgb- (1) MhY, (2) cQZwUqv, (3) iaZ; (4) msMVb I (5) `enkto`i
wfwEtZ iaZ;| Gme Abfuzgj-K Df'ik'i gva`tg tKvb e`w³ tKvb ielq m`utK`
wKifc gtbvive, AvPri AvPiY cKvk Kti Zv Rvbr hvq|

gtbvckxR Df'ik"

th Kv`m`u`v`tb gb I tckxi mgšq mva`bi cQqvRb nq tm,tjv`K gtbvckxR
`qZv ejv hvq| thgb- (1) iAv`bi e`enwmi K KvR, (2) KwL. wK`q`vq nuj Pvl w`tg
Rwq `Zwi, (3) ewEgj-K wK`q`vq tmjvB tgwkb tgivgZ Kiv BZ`w`| gtbvckxR
`qZv`K cB fivM fivM Kiv ntqtQ|

- Abk`iY (Imitation): th mKj KvR KiZ wMtg tckxi mgšqi cQqvRb nq bv|
- nvtZi KvR (Manipulation): Av`k Abviti A`ev iut`Rbv tgvZvteK KvR
m`ubckiv|
- Lw`bvwU KvR wLw`fivte Kiv (Precision): `iz I wLw`fivte KvR m`ubckiv|
- Mšbv (Articulation): wvfbckv`h` i gta` avivewnk`fivte mgšq mrvab Kiv|
- mnR`kiY (Naturalization): cQZwUqZ Abk`ij b KiZ KiZ `fivte cwiYZ
nl qvi dtj cieZ`mg`q Zv `qswUq Ges `Z`Z`fivte NUtZ `v`K|

wK`q`vi yMZgvb wbu`Z Kivi Rb` ielqe` iPbvq, wK`Lb-tkLv`bv Kv`h`ej
cwi Pvj bvq, gj`vqb BZ`w` t`q`i` ewYZ Df'ik`mg` AbvitiY Kiv GKvšI cQqvRb|
wK`q`vi gva`tg eZg`v`b th cQZ`vkv Kiv n`Q Zv nj wK`q`v`x`p m`g`w`M`K w`K`v`k mrvab
Kiv| Avi GwU KiZ ntj wK`q`v m`U`xq Df'ik` Aek`B AR`bi e`e`v`v`KtZ nte|
dtj wK`L`bi yMZgvb AR`b m`eci nte|



cv`V`Ei gj`vqb 8.3

A) msi`q`B D`Ei c`k`e

1. cQwMZ wK`q`vi gvb msi`q`Y Dcv`vb Kqwu I Kx Kx?
2. `i`wK`q`vi yMZgvb wbu`Z`K`i`f`Yi mgKvij`xb tKškj` ,tj v Kx?
3. avivewnk` cQwq`wfwE`K tKšktj`i avc` ,tj v Kx?
4. wK`Lb m`U`xq Df'ik` Kqwu I Kx Kx?
5. Avb m`U`xq Df'ik` ,tj v Kx?
6. Abfuzgj-K Df'ik` ,tj v D`j`L` Ki`ab|
7. gtbvckxR Df'ik` Kqwu I Kx Kx?

Av) iPbv`gj-K c`k`e

1. cQwMZ wK`q`vi yMZgvb msi`q`Yi Dcv`vb ,tj v e`v`L`v`v` Ki`ab|
2. `i`wK`q`vi yMZgvb wbu`Z`K`i`f`Yi Avav`bK tKškj` mg` Avtj`v`Pbv` Ki`ab|
3. `i`wK`q`vi yMZgvb wbu`Z`K`i`f`Yi wK`q`v m`U`xq Df'ik`i` iek` w`eiYmn` Gt`i`
c`f`ve` D`j`L` Ki`ab|

იკვლევ MYZსყობ (Democratization of Education)

mevi Rb` იკვლევ

იკვლევ MბY ბvMwiჰKi tგŕij K AwaKvi | GB AwaKvi cაZიბZ Kivi Rb` ōmevi Rb` იკვლევ (Education for All) Kihჟiტი გვატიგ იკვლევ მჰhM მყო Kჰi ბvix ცjაჰI იკვლევ mgZv weavb იბიბZ KiჰZ nჰe| mevi Rb` mgvbჟიჰე იკვლევ მჰhM მყო Kiჰj B Pjჰე ბv, tm mvt_ იკვლევ , YMZგvb msiჟY I ეჰxKiჰYi cაPōv Ae`inZჟიჰე PjჟvZ nჰe|

YMZგvb იბიბZKiჰY Av` k`cuiჰcჟიჰZi Dcv` vb

იკვლევ , YMZგvb იბიბZKiჰY Av` k`cuiჰcჟიჰZi cაvb `ჟDcv` vb nj :

- GKvჟWigK cuiჰcჟიჰZ
- tckvMZ cuiჰcჟიჰZ

GKvჟWigK cuiჰcჟიჰZ

GKvჟWigK cuiჰcჟიჰZi AvI Zvfჰ Dcv`vb ,tjv nj : იკვლევ ielqe` (Content), e`envi (Treatment), AeKvWჟg (Infrastructure), იკვლევ ბKkv (Curricular design) BZ`v | Gme Dcv`vb mgZჟიჰე cჟqბ I cაqvm იბიბZ nჰj იკLჰbi , YMZ გvb იბიბZKiY mჰე nჰe| იბჰeDcჰi eიYჰ cაZ`Kiu Dcv`vb msvჟBჟიჰე Avtj vPbv Kiv nj :

ielqe`

ielqe` (Content): იკვლევ ielqe`i cuiგvY I Zvi cui mi Ges MfxiZvi wfvEჰZ Gi , YMZგvb იბიჟicZ nq| ielqe` Dc`vcbvq მეჰKl/mv`vბZK ZEj I Z` cuiჰtekb Kiv Ges cv`mჰPi AvI Zvfჰ mKj w`K mჰუჰK`ielqe` iPbv Kiv nჰj იკLჰbi , YMZგvb იბიბZKiY mჰე nჰe|

cv`vჰb e`envi thM` c`vZ

e`envi (Treatment): cჟvZ ielqe` იკვლევ-იკLჰbi mgq h_vh_ c`vZi cჟivcvj e`envi , Avb` `vqK იკLb ielqe` Ges იკLb AMvMZ cui გvcჰvM, `ea I იბჟჟthM` gj`vqბ tKŕkჰj i e`envi იკვლევ , YMZგvb იბიბZ Kჰi |

AeKvWჟgMZ w`K

AeKvWჟg (Infrastructure): იკვლევ , YMZგvb იბიბZ KiჰZ nჰj იკვლევ AeKvWჟgvi (1) tჟŕZ Ges (2) გvბე mჰუ` GB `ჟ w`ჰKi cაZ , iაZj w`ჰZ nq| tჟŕZ AeKvWჟg Dბჟბi mჰ½ mჰ½ გvბე mჰუ` A_ჟ `ჟ, AvfÁ cკvmK (cაvb იკვლევ/cui Pvj K/ Aa`ჟ) Ges thM, cაKჟYcაB I იკვლევZvq cაZkაZex იკვლევ იბჟqvm GKvŕŕ cაqvrბ|

იკვლევ ბKkv

იკვლევ ბKkv (Curricular Design): `i იკLჰbi იკვლევ cჟqბი tჟჰI ielqe` Mŕbivq arivemKZv (continuity), Abჟg (sequence), ALŪZv (integration) AZ`ŕŕ `kwi K nჰZ nჰe| იკვლევ , YMZგvb იბიბZKiჰY th me Dcv`vb იკვლევ Dჰi k` I ielqe` იბაჟიჰY Kihŕi fujKv cij b Kჰi tm ,tjv nj :

- m`vŕŕ MბY- `b w`b Rჟჰბი ბbv mgm`v mgvavჰბი mWK Dcvq mbr`KiჰY mnvqZv cაvb Kiv|

ᄡ Ae GWKkb

- **mᄡZ'i mÜvb** - weifbæe³e" t_ᄡK tKivüU mZ" Zv ubaᄡY KiᄡZ cviv Ges mᄡZ'i Abvivi x nI qv|
- **RæbaviY`ᄡZv**- Ræbgvb DbzKiᄡY I Kvhᄡúv`ᄡb mivaviY nviZqvi I hšcwiz`ᄡZvi mᄡ_ e`envi KiᄡZ cviv|
- **cwievZᄡ Ae`vi mᄡ½ ubᄡRᄡK gmbᄡq tbi qv** - Ávb, mgvR I mvgvRK gj`teva cwievZᄡ nᄡQ| Gme cwieZᄡbi mᄡ_ mᄡPZbfvᄡe ubᄡRᄡK gmbᄡq tbi qvi thvM`Zv ARᄡ Kiv|
- **bu`vbK tmᄡ`h²** e`v³i AvPvi AvPiᄡY ikí I tmᄡ`hᄡvᄡai cKvk|

tcᄡdkbvj cwiᄡcᄡᄡZ

tcᄡdkbvj cwiᄡcᄡᄡZi Av`k²gvb cwi gvᄡci Rb" weI qe`i DchᄡZv I Dwi`ó, j ᄡ" Ges Dᄡí k" wfiE inᄡᄡe MY" nq| ubᄡg²ᄡ, ᄡj v m²úᄡK²ᄡᄡᄡᄡᄡ Avᄡj vPbv Kiv nj |

- **Dwi`ó** (Purpose)
Dwi`ó e`vcK Aᄡ_ e`eüZ nq Ges Dwi`ó ARᄡbi gᄡa" w`ᄡq mᄡi-cᄡvix dj j v f nq|
D`vniY: GKüU MYZvšK ivó²I mgvᄡR ikᄡᄡ_vxᄡv mᄡvMvi K nᄡe|
- **j ᄡ"** (Aims)
j ᄡ" nj RvZxq bviZi AbviviᄡY Ges AMüaKvi wfiEᄡZ cᄡxZ Kvhᄡug ev`éqvᄡbi gva`ᄡg KviᄡᄡZ dj |
D`vniY: ikᄡᄡ_vx²m²v²ieavvbK weia m²ᄡÜ AeivZ nᄡe|
- **Dᄡí k"** (Objectives)
ikᄡᄡ_v Kvhᄡᄡᄡi gva`ᄡg th KviᄡᄡZ dj j v f Kiv nq Zᄡᄡ mivaviYfᄡe Dᄡí k" ej v nq|
D`vniY: t`ᄡki RvZxq msm` ev ivó²üZ ubeᄡᄡᄡbi c²xüZ m²úᄡK² cᄡk² mivK DEi w`ᄡZ cviᄡe|

ikᄡᄡ_v Dwi`ó, j ᄡ" I Dᄡí k" hZ mᄡv²ᄡ ᄡ nᄡe Zv ev`éqvᄡbi weifbæavᄡc wᄡᄡ÷ g j m-Gi m²ᄡebv ZZ Kᄡg hvq| dᄡj ᄡ, YMZgvb ARᄡ ubiᄡZ nq|



civVvEi gj`vqb 8.4

A) iPbvij-K cᄡæ

1. ikᄡᄡ_v ᄡ, YMZgvb ubiᄡZKivᄡY mvgvRK, A_ᄡ²üZK I ivRᄡ²üZK tcᄡᄡ_vcU wek`fᄡe Avᄡj vPbv Ki ab|
2. ikᄡᄡ_v ᄡ, YMZgvb ubiᄡZKivᄡY GKivWigK cwiᄡcᄡᄡZi weifbæDcv`vb e`vL`v Ki ab|
3. tckvMZ cwiᄡcᄡᄡZ Kx Kx D`vni Ymn weeZ Ki ab|

cW 8.5

Dvgŷ ukLb I `i-ukŷŷiq , YMZgvb ubwDZKiY gvb`U - 1

[Norms of Quality Assurance in Distance Education -1]

Df`ik`

GB cW tk`l Avicub –

- `i-ukLtb c`ekwaKv`i i m`shvM ukifc Zv ej tZ cvi`teb;
- `i-ukLtb i , YMZgvb ubwDZKi`Yi gvb`U , t`j v D`tj L Ki`Z cvi`teb;
- `i-ukLtb i , YMZgvb ubwDZKi`Yi ukŷŷŷiq web`vm c`uqv eY`Bv Ki`Z cvi`teb Ges
- `i-ukLtb ukŷŷŷiq ev`evq`bi c`avb c`avb Kiv`eig weeZ Ki`Z cvi`teb|

`i-ukLtb i , YMZgvb ubwDZKi`Yi Rb` we`tklAMY weifbæ`wD`Kiv t`_tK weifbæ aib`i gvb`t`U i K`_v etj`t`Qb| Gme ukŷŷŷie`M`Yi g`ta` i vD`U wJ, ewa`bv_ KivDj we`tkl fite D`tj L`shvM`|

`i-ukŷŷiq c`ekwaKv`i i m`shvM

Avigiv Rvb, th t`Kvb ukŷŷŷiq Kiv`eig cwi Pij bri Rb` c`u`g c`uqvRb KZK , t`j v m`ybw`e Ges ce`wba`wZ Df`ik`| t`Zgvb `i-ukŷŷŷiq Rb`I KZK , t`j v m`ybw`e Df`ik` ce`w`y w`Piv`Z Ki`Z nq| Zte `i-ukŷŷŷiq GKw Ab`Zg Df`ik` n`t`Q m`yav ew`A`Z uk`S`ukŷŷŷiq M`h`Y B`Q`e e`w`t`i Rb` ukŷŷŷiq m`shvM m`yD Kiv| dtj ukŷŷŷiq M`h`Y B`Q`e th m`Kj ukŷŷŷiq_x`_t`hgb- t`ckvMZ ev Ab` t`Kvb A`sh`v`t`qi Rb` c`u`vMZ ukŷŷŷiq c`u`Zov`tb fiv`Z`n`t`q ukŷŷŷiq v`f Ki`Z cvi`t`Qb bv Zviv mnt`RB `i-ukLtb c`e`t`ki m`shvM t`ct`Z cv`t`ib| GQivon G`t`Z c`u`vMZ ukŷŷŷiq avivi ukŷŷŷiq_x`_P Rb`I Kg Li`P w`bR Ae`v`tb t`_t`K ukŷŷŷiq j`v`fi m`shvM Dvgŷ i`t`q`Q| Dvgŷ ukLtb i Avi GKw Zvrch`e`Y`e`w`k`o` nj ukŷŷŷiq_x`_ ukLtb i Rb` ch`w`B mgq c`v`q A`_P ukŷŷŷiq_x`_q`Kiv t`c`u`M`t`g fiv`Z`n`t`q Zv m`u`b`æ`Kivi Rb` A`t`c`ŷŷ`KZ. `x`N`mgq`m`x`v t`ct`q _v`t`K| Ab` fite ej v hiv`q c`u`vMZ ukŷŷŷiq thgb mg`t`qi Kov`Kw _v`t`K, Dvgŷ ukLb e`e`v`q Zv A`t`b`K`Uv b`g`b`iq|

Gme `ew`k`to`i Rb` GKw` t`K thgb eZ`g`v`b we`tk| Dvgŷ ukŷŷŷiq e`e`v` Rb`ic`q`Zv j`v`f Ki`t`Q Aciv` t`K w`bR Ae`v`tb t`_t`K `^`^` KgRv`U w`b`w`e`w`m`u`v`b K`i`l D`P`Zi ukŷŷŷiq v`f Kiv m`e` n`t`Q|

, YMZgvb ubwDZKi`Yi gvb`U

Dvgŷ ukLb I `i-ukŷŷŷiq i , YMZgvb ubwDZKi`Yi we`l`t`q eZ`g`v`tb ukŷŷŷie`M`Yi g`ta` c`k`æ D`t`v`t`Q| ukŷŷŷie`M`Yi g`t`Z meR`b`x`b`f`ite weifbæ gvb`t`U gva`t`g GB , YMZgvb ubwDZKi`Yi m`e`| w`b`P Gme gvb`U I G`t`i c`avb Dcv`v`b`m`g`r` D`t`j UL Kiv nj :

ukŷŷŷiq (Curriculum): ukŷŷŷiq`m`t`gi w`w`R`v`Bb, we`l`q`e`v`I we`b`vm BZ`w`w`|

Dvgŷ ukŷŷŷiq ōvi mevi Rb` Aewi Z

tKwiqv

**ii cvej K Ae
tKwi qvi ikŕivmug
wRvBb**

- Rvi tci gva`tg eZŕvb cŕqvRbxqZv Dcj wäKiY ;
- AMŕiaKvi ubaŕi Y;
- Dŕi`k` ubiŕcY;
- weIQe`' ubeŕŕb;
- ev`évqb tKŕkj I cŕmuv chŕj vPbv;
- ev`évqŕbi Rb` cŕqvRbxq thvMvb wbuŕZKiY Ges
- Kvhŕjg gj`vqb|

eisj v`k

**eisj v`k i ikŕivmug
wRvBb**

- RvZiq`kŕ I bmvZgvj v chŕj vPbv;
- ikŕivi RvZiq j`ŕ chŕj vPbv;
- j`ŕ I Dŕi`k` chŕj vPbv I cŕtubaŕi Y;
- msikŕ ikŕiv`ŕi i cŕŕŕK thvM`Zv ubiŕcY;
- weIQ I tkYwŕiEK wKLbμg cŕŕqb;
- wKLbdj cŕŕqb;
- cv`mŕŕ i Pbv;
- tj LK I m`úv`Keŕ` i Rb` wŕ`Rbv cŕŕqb;
- weIQe`' i Pbv, gj`vqb I m`úv`bv;
- PvkZxKij xb ikŕivmug we`liY cŕkŕjY I PvkZx ce`cŕkŕjY Ges
- gj`vqb|

weIQe`'

ikŕivmug wRvBŕbi cŕg KivRiU nj Dŕi`k` ubaŕi Y/cŕŕqb| Zvi cŕii KivRiU nj ubaŕi Z Dŕi`k` ARŕbi Rb` weIQe`' kbr³ Kiv| Dŕi`k` ARŕbi Rb` cŕqvRbxq weIQe`' kbr³ KiZ nte|

Ab` weŕePbvq weIQe`' hZB , iæZcYŕnDK bv tKb Dŕi`k` ARŕb mnvqK bv nŕj Zv tKvbŕiŕeB ubeŕŕb Kiv hŕŕe bv|

weIQe`' ubaŕi ŕY weŕfbæcŕZŕvb I ikŕivmug weŕklÁMY th me wbyŕqK e`envi Kŕi _vŕKb Zvi gŕa` AvŕŕŕZK ikŕiv cwiKíbv Bbŕ÷wDU (International Institute of Educational Planning), c`wiŕmi wbyŕqKiu GLvŕb Dŕj - L Kiv nj | GQvov Avigiv ŕikŕiv e`e`rcbv I ikŕivmug Dbæbŕ weIQe`' GZ` weIQe`' cŕovQ|

**AvB AvB B ic
wbYŕqK**

- Dŕi`k`i mŕ½ cŕmŕ½KZv
- mŕúŕZK weIQ
- ikŕiv_xŕi Zvi cwiŕŕŕki mŕ½ cŕmŕ½KZv
- weIQe`'i fvi mvg`Zv
- weIQe`'i KivŕŕgvMZ weŕ`vm|

welqe'Pqtbi AvapK aviYv

AvapKKvtj wkwjvtgi welqe' mbr³KiY wbtg³ wtki cōZ, iaz; Avtvc Kiv ntq_vtk| thgb:

**welqe'Pqtbi
AvapK aviYv**

- msikō welq Ávbj vtfi tqtí mbr³KZ.welqe'h_vh_ wK bv ?
- welqe'wPivqZ A_er meRvtj i Dc:thvMx wK bv ?
- Rieb Dc:thvMx wK bv ?
- wkwjv_xP Kvq AvKI Pq wK bv ?
- MYZmšK mgvR e'e'vi weKvk I Dbq:thbi mnvqK wK bv ?
- mgKvj xb Ávb weÁvtbi m½ welqe'm½wZcY⁹wK bv ?
- welqe'wkwjv_xP mRbxk³ I tgsnj KZvi weKvtk mnvqK wK bv ?

Gme cōkē h_vh_ DĒi welqe'i gva'tg cōvtbi e'e'v Aek'B_vKtZ nte|

wkwjvtgi welqe'web'im cōqv

**welqe'web'im
cōqv**

welqe' mbr³ Kivi ctii avcū nj GKū gtv%ÁmbK I AvapK cōqv AbyiY welqe' web'im Kiv| wkwjvtgi welqe' web'vfm weklÁMY bivr aĩbi web'im cōqv K_v etj tQb| weklÁMĩYi gta' Dtt:thvM' ntjb- wj `v Ziev, tehW `š_, evYθ, UvBjvi I jvbā cōy|

wbP welqe'web'vfm gtv%ÁmbK I AvapK cōqv avc_tjv Dtt: Kiv nj :

- avivemKZv (continuity)
- Abyg (sequence)
- ALŪZv (integration)
- cōyveĒ (reiteration)

ĩ-wkwjvi wkwjvg ev'evq:thbi cāvb cāvb KvhPig

wkwjvtgi Dtk' Abyvĩ welqe'wPivqZKiY, web'im, iPbv I wkwjK cōqtYi Avtqvrthbi ga' w'tq cōvZ wkwjvg ev'evq:thbi Kvr iia nq| ev'evqb cōqv wkwjvtgi Avl Zvfš cwi gmRš I bzē msthvRZ welqe' tKvb tKvb c_xwZtZ tkLvthvi e'e'v Kiv ntj KvhRi wklb Nuē tm m=útK⁹wkwjKe,`tK/wDUie,`tK wkwjvg we'liY cōqtYi gva'tg AemZ KitZ nq| GQvor cōqtYv_xPv tKvb cōqv wklTj wklthbi AMwZ nte Zv 'úofvte cōqY w'tq tkLvthZ nte|

cĕkŕŕY Kvhŕi nŕqŕQ ũK bv tm m`uŕŕKŕRivbi Rb` gj`veaviY (Assessment) KiŕZ nq| gj`veaviY t_ŕK hw` cĕkŕŕŕYi tKvb cĕkvi NvUwZ cwi jwŕŕZ nq Zŕe Zv `ŕ Kivi Rb` weŕkl tmkb AvŕqvRb Kŕi cŕivq ũkLŕbi e`e`v Kiv cĕkŕRb| hw` Zv m`e bv nq Zŕe ũwŕf I tiwŕI ev ũbDR tj Uvŕii gvaŕŕg cĕkŕŕŕYi e`e`v Kiŕj ũkLŕbi ŕ YMZgvb ũbŕŕŕZ nq|



civŕvĕi gj`vqb 8.5

A) mŕŕŕB Dĕi cĕe

1. `ŕ ũkŕŕvq eZŕŕŕb RbŕcŕZv j vŕfi AŕŕbŕZ Kvi Y Kx Kx?
2. `ŕ ũkŕŕvi ŕ YMZgvb ũbŕŕŕZKiŕYi gvb`Ū ŕj v Kx?
3. ũkŕŕvŕg ũeb`im cĕŕqv Kx?
4. tKwŕi qv I eijsj v`ŕki ũkŕŕvŕg ũeb`vŕmi Zŕŕv Kiab|
5. AvB AvB B ũc ũkŕŕvŕŕgi ũel qe`Pqŕbi ũbYŕqK Dŕj ũ Kiab|
6. ũel qe`Pqŕbi AvŕŕK avi Yv Kx Kx?
7. ũkŕŕvŕŕgi ũel qe`tKvb tKvb cĕŕqv ũeb`im KiŕZ nq?

Av) iPbvŕj-K cĕe

1. `ŕ ũkŕŕvq cĕekŕŕKvŕi i mŕŕŕM e`vL`v Kiab|
2. ŕ YMZgvb ũbŕŕŕZKiŕYi gvb`Ū Avŕj vPbv Kiab|
3. ũkŕŕvŕŕgi ũel qe`ũeb`vŕmi cĕŕqv I AvŕŕK avi Yv ũeeZ Kiab|
4. `ŕ ũkLŕb ũkŕŕvŕg ev`ŕvŕŕbi Kihŕ eYŕv Kiab|

የሰነድ 8.6

የድንገተኛ ጥራት ማረጋገጫ ስርዓቶች ማረጋገጫ ስርዓቶች - 2
[Norms of Quality Assurance in Distance Education -2]

የጥራት ማረጋገጫ

የሰነድ ጥራት ማረጋገጫ -

- የሰነድ ምርመራ የሚሰጠው ጥራት ማረጋገጫ ስርዓት ነው።
- የሰነድ ስርዓት ማረጋገጫ ስርዓቶች ማረጋገጫ ስርዓቶች ማረጋገጫ ስርዓቶች ማረጋገጫ ስርዓቶች ናቸው።
- የሰነድ ስርዓት ማረጋገጫ ስርዓቶች ማረጋገጫ ስርዓቶች ማረጋገጫ ስርዓቶች ማረጋገጫ ስርዓቶች ናቸው።
- የድንገተኛ ጥራት ማረጋገጫ ስርዓቶች ማረጋገጫ ስርዓቶች ማረጋገጫ ስርዓቶች ማረጋገጫ ስርዓቶች ናቸው።
- የድንገተኛ ጥራት ማረጋገጫ ስርዓቶች ማረጋገጫ ስርዓቶች ማረጋገጫ ስርዓቶች ማረጋገጫ ስርዓቶች ናቸው።

የሰነድ ምርመራ ጥራት ማረጋገጫ

የድንገተኛ ጥራት ማረጋገጫ ስርዓቶች ማረጋገጫ ስርዓቶች ማረጋገጫ ስርዓቶች ማረጋገጫ ስርዓቶች ናቸው።

የጥራት ማረጋገጫ ስርዓቶች

የጥራት ማረጋገጫ ስርዓቶች ማረጋገጫ ስርዓቶች ማረጋገጫ ስርዓቶች ማረጋገጫ ስርዓቶች ናቸው።

የጥራት ማረጋገጫ ስርዓቶች

- የጥራት ማረጋገጫ ስርዓቶች ማረጋገጫ ስርዓቶች ማረጋገጫ ስርዓቶች ናቸው።
- የጥራት ማረጋገጫ ስርዓቶች ማረጋገጫ ስርዓቶች ማረጋገጫ ስርዓቶች ናቸው።
- የጥራት ማረጋገጫ ስርዓቶች ማረጋገጫ ስርዓቶች ማረጋገጫ ስርዓቶች ናቸው።
- የጥራት ማረጋገጫ ስርዓቶች ማረጋገጫ ስርዓቶች ማረጋገጫ ስርዓቶች ናቸው።
- የጥራት ማረጋገጫ ስርዓቶች ማረጋገጫ ስርዓቶች ማረጋገጫ ስርዓቶች ናቸው።
- የጥራት ማረጋገጫ ስርዓቶች ማረጋገጫ ስርዓቶች ማረጋገጫ ስርዓቶች ናቸው።
- የጥራት ማረጋገጫ ስርዓቶች ማረጋገጫ ስርዓቶች ማረጋገጫ ስርዓቶች ናቸው።
- የጥራት ማረጋገጫ ስርዓቶች ማረጋገጫ ስርዓቶች ማረጋገጫ ስርዓቶች ናቸው።
- የጥራት ማረጋገጫ ስርዓቶች ማረጋገጫ ስርዓቶች ማረጋገጫ ስርዓቶች ናቸው።

የጥራት ማረጋገጫ ስርዓቶች ማረጋገጫ ስርዓቶች ማረጋገጫ ስርዓቶች ማረጋገጫ ስርዓቶች ናቸው።

tc̈Mög Pj vKvj xb Kvḧ

tKvm̈c̈Zʻbi c̈tëAviv Kiv n̈tq̈Qj th Dc̈ti eiv̈Z me ẅK I melq m̈WKfv̈te c̈övb Kiv n̈tj tKvb Am̈ÿav n̈te bvl ẅKš̈ tc̈Mög Pj vKvj xb mg̈tql ẅKQÿm̈KQym̈gm̈v t`Lv ẅtZ cv̈ti | thgb-

**tc̈Mög msikó
mgm̈ẅ**

1. tKvb tKvb mel̈tq A`v̈m̈vBbẗgU _vK̈te Zv ubäñY Kiv nq ub; KLB, Kvi Kv̈tQ Rgv ẅtZ n̈te Zv ejv nq ub|
2. A`v̈m̈vBbẗgU gj`vqb tK Kiteb, b̈af̈ tKv_vq tKv_vq cv̈ẄtZ n̈te Ges GRb` ubäñi Z tKvb dïẗgU _vK̈te ẅKbv, Avi ḧẅ _v̈tK Zte tK meiev̈n Kite BZ`ẅ |
3. tKvb ẅDUi e`ij n̈tj ev Am̈ÿ n̈tj Zvi c̈wïeẗZ`Ziv̈ñẅYKfv̈te ub̈ẗqv̈Mi e`e`v̈ tK Kiteb Zvi ub̈t` Rbv t` I qv nq ub|
4. Btj KUibK ẅgm̈Ẅqvi gva`tg KLB, tKvb mel̈tq, ẅUẅf I tiẅVI tc̈Mög Ges tUij Kbdv̈ti Y, ẅFẅVI Kbdv̈ti Y Ab̈ÿZ n̈te Zv D̈tj L Kiv nq ub|
5. th mg̈tq 4-G eiv̈Z tc̈Mög (ẅUẅf I tiẅVI Ab̈ÿvb, tUij Kbdv̈ti Y, ẅFẅVI Kbdv̈ti Y) Av̈ẗqv̈Rb Kiv nj Zv ẅKñ̈v_ẍP Rb` Dc̈thv̈Mẍ bv nI qv Zvi ẅeK̈i mgq ubäñY BZ`ẅ b̈v̈bv aïẗbi mgm̈v D`e n̈tZ cv̈ti |

aviveẅK gub̈Uis

Gme mgm̈v h_vmg̈tq mgv̈aẗbi Rb` aviveẅnKfv̈te gub̈Uis Ki ẗj tm̈_tjvi AwäKiv̈K Ziv̈ñẅYKfv̈te mgv̈av̈b Kiv m̈ae n̈te, d̈tj gub̈ ub̈ẅöZfv̈te AR̈b̈ Kiv n̈tq̈tQ ejv hv̈te|

tc̈MögvïEi Kvḧ

tc̈Mög c̈öZ̈ cëI tc̈Mög Pj vKvj xb mg̈tq th me thv̈Mvb c̈övb Kiv n̈tq̈Qj Zv jv̈Mm̈B I cḧñ̈ ẅK bv Zv tc̈Mög DEi Kvḧ t`_ẗK R̈vbv hv̈q| GQ̈vor tc̈Mög̈gi th me D̈ẗi`k` ubäñY Kiv n̈tq̈Qj tm̈_tjv AẅR̈Z n̈tq̈tQ ẅK bv tm̈UvI R̈vbv hv̈q| ẅDUwis tK̈t`ñ̈ mg̈š̈q̈Kvixi Z`vi ẅK, ẅKñ̈v_ẍP AM̈ñ̈Z gj`vqb, e`enẅi K KvR BZ`ẅ h_vh_bv nI qvi Kvi ẗy dj Av̈kv̈bj̈c bvl n̈tZ cv̈ti| Zv Q̈vor ẅKñ̈v_ẍP i AẅfgZ ev Aẅf̈thv̈M c̈i t`_ẗKI GZ` mel̈tq ẅKQÿñ̈ ẅẗKi BẅzZ cv̈l qv hv̈q|

tKvb tKvb tKv̈tm̈P K̈ẗjei L̈ÿ teik Avevi tKv̈bïUi L̈ÿ Kg n̈tZ cv̈ti| Gi c̈ti i jñ̈Yxq ẅK nj cieZẍẅm̈tg÷v̈ẗii tiẅR̈t÷kb, cv̈V̈m̈vg̈M̈i ẅeZiY, ẅDUwis ïiai Zwi L, dj c̈K̈v̈ẗk ẅej`nI qvi `iäñ̈ AKZKvḧc̈ö_ẍc̈iẍñ̈v̈q Ask̈M̈ñ̈Y Ki ẗZ cv̈ti ub BZ`ẅ |

tKvb tKvb tñ̈ñ̈I cv̈V̈m̈vg̈M̈i Dc̈thv̈MZv, ẅDUwis-Gi gub̈ BZ`ẅ m̈aëẗK̈P ÄẗbK ẅKQy R̈vbv hv̈q hv̈ tc̈Mög̈gi m̈vg̈ẅM̈K gub̈ eẅẍtZ AZ`š̈, iäZc̈Y`F̈ñ̈g̈Kv cv̈j b K̈ti _v̈tK|

ukġiv_xp KuztZji Muzaviv iiaet_tK cġšK chġchġKifc?

**uc-tU ÷ I tcv ÷
tU ÷ -Gi Zvrchey[©]
cv_R**

th tKvb ukġiv Kvhġtg fivZRZ. ukġiv_xp fivZRjv xb mgġq Ziv`i Avb, `ġZv I Abġvab ġgZvi gvġv ukġifc uQj Zv Avgiv tKvm[©]ce[©]Afxġvi (Course pre-test) gva`tg RvbZt cvii | tKvm[©]mgvġB Afxġvi (Course post test) djvdtji c`vUvġb[©] Zvrchey[©]cv_R` t_tK ukLġbi AMMvZi w K vbt`Rbv cvl qv hvq | GB Afxġivġtqi dtji cv_R` hv BvZevPK I Zvrchey[©]ng Zte ejv hvq th, ukLġbi AMMvZ nġqtQ | A_ġ ukLġbi , YMZ gvġbi DbvZ NġUġQ |

, YMZgvb vbuġZKiġY j vbs[©]vi tmm[©]e`e`v tKgb?

j vbs[©]vi tmm[©]e`e`v

ukġiv Kvhġtg vbuġvġeI mgZvte cvii Pvj bvi Rb` meġMġ cġqvRb GKvU mej ukġiv AeKvVġgv | Gi e`vZvg nġj ukġivi , YMZgvb ARġ I Zv vbuġZKiY e`nZ nq | AeKvVġgvi ciB vbtqvM KiġZ nq vevfbvewġtqi GK`j mġġ I AvfÁZvm[©]vbv ukġivK, hvġ`i e`vcbvq vev`v PPġ cviiġek mġġ nq I cvii Yġtg cġZġvbuU tgav vevvġki tK`^a vntmte Mġo Iġv | Avi GB mġġ I AvfÁZvm[©]vbv e`v³ iv Zvġi i vbi šli cġPġvi gva`tg ukġivi Dbqġb Ae`vb ivLġZ mg_ġb |

tKvb tKvb tġġġ , YMZgvb vbuġZ Kiv hvq?

Dvgġ I `ġ ukLġb , YMZgvb vbuġZKiY e`e`v cġvbZ vZbvU tġġġ Kiv nġq _vġK | thgb-

(K) mvgvMġ ukġiv e`e`vi GKvU Avvġ`Q` Aġ vntmte MY` Kġi |

(L) mKġj vġġj ukġiv m[©]vġq KiYxq mKj KvġRi , YMZgvb vbuġZKiġYi cġPġv Ae`vZ tiġL |

(M) ukġivvg cġqv t_tK iiaKġi ukġivvg vev`liY chšimKj KgRvġU ukġivi , YMZgvb vbuġZKiġYi cġPġv vbi šli fvte Ae`vZ tiġL |

Dcġi vZbvU tġġġK mnR Kġi ejv hvq th t`ġki mgMġukġiv e`e`vq A_ġ RvZxq ukġivvZġZ, ukġivvg cġqvġb, ukLb mvgMġ iPbvq, cvV`vġb, gj`vqġb, ukġivK cġġġġY GgbvK ukġiv e`e`vcbv I Zġvavġb ukġivi , YMZgvb vbuġZKiġYi tPġv Ae`vZ ivLv GKvšicġqvRb |

ukġivi , YMZgvb vbuġZKiġYi cġve

- Dvgġ ukġivi Avl Zvq th `ġi i Rb` ukġiv tġMġvU cġqv Kiv nġqtQ Zvi j ġ` I Dġġk` AvRZ nġqtQ uk bv Zv %ve`ġ³ Kfvte gj`vqġbi vfvġZ vMv/mvUvġġKvU cġvb Kiv hvq |
- vMvġi h_v_Zv mKj KgRvġU vbi tġġfvte cġvY KiġZ cviv hvq |
- t`ġki mvgvMġ KgRvġU AvRZ , YMZ gvġbi ukġivi mvġi ivLv m[©]eci nq |
- AvRZ ukġiv bZb bZb mgm`v mgvavġb e`envi KiġZ cviv hvq |

- ɪkʲvi gvaʔg AɪRʒ Ávb, `ʲZv, Abɔveb, gj`tefta BZ`w` (1) ɪmɔvšÍ MhʲY, (2) mZ` mÜvʲb, (3) mɔʲvte Rxeb avitʲY, (4) cwi ewZʒ Ae`vi mʲ½ ɪbRʲK gmbʲq ɪbʲZ, (5) thvMvthvʲM Ges (6) bv` ɪbK tmš` hʲmsi ʲʲY mrvqK nq|



civVvEi gj`vqb 8.6

A) msɪʲB DĚi cĕæ

1. ɪkʲvi_xʲmrvqZv tmevi chʲq Kx Kx?
2. tKvmDĚi KvR, ʲj v Kx?
3. ɪcʲtU ÷ I tcv ÷ tUʲ ÷ i cv_ʲZv rchʲeʲʲntʲ Kx NʲU?
4. j ɪbšwi ʲmvmʲe`e`v ej ʲZ Kx eʲvq?
5. ʲYMZgvb ɪbɪDZKiʲYi tʲʲĪ, ʲj v Kx?
6. ɪkʲvi ʲYMZgvb ɪbɪDZKiʲYi cĕvie Kx Kx?

Av) iPbvj-K cĕæ

1. ɪkʲvi_xʲmrvqZv tmevi chʲq, ʲj v Avʲj vPbv Ki ab|
2. ʲYMZgvb ɪbɪDZKiʲYi j ɪbšwi ʲmvmʲe`Gi fʲvqKv weeZ Ki ab|
3. ɪkʲvi ʲYMZgvb ɪbɪDZKiʲYi e`e`v tKvb tKvb tʲʲĪ Kiv hvq?
4. ɪkʲvi ʲYMZgvb ɪbɪDZ ntʲj tKvb tKvb tʲʲĪ cĕvie cotē etʲj Avcɪb gʲb Kʲi b Zvi GKɪU nek` Zvʲj Kv cĕvqb Ki ab|

- Course design and development
- Learner support
- Media for learning
- Gender perspective for on-line learning

GB `wj tj `úofvte D tj - L Kiv AvtQ th, cÖZiU uk¶iv cÖZövb ubR`^Pvnn`v, mvg_© ¶lgZv Abgvqx Ögvb ubiÖZKiYÖÖ KivR`i iæ Kite, Ab` t`tki w`tk Zvuktg Aer`é tKvb cwi Kí bv Zviv KLtbn nvtZ tbtv bv|

Kvhfúv`b chq gtb ivLtz nte msukö uk¶iv cÖZövb gvb ubiÖZKiY `ÜgvIv h_vimZ KivRi itqtQ|`iaycÖqvRbxqZv ejs Gi cwi eZB, cwi eaB ev cwi gvRÖ Ges AveiZfvte GvutK cÖqvM Kti Pjvi KivR Kivi A_B nj Ögvb ubiÖZKiYÖÖ|

Zte j¶ ivLtz nte thb uk¶Kmn Ab`vb` Kgr` KLtbn ubtRt`i Av`Zj ügvKi m`vb etj gtb bv Ktib| KugvU ej tQ ÖIt's about acknowledging that quality can always be improved and establishing procedures that ensure that staff are continuously questioning how processes are working with a view to making them better Ö.

tKvb tKvb w`tk mZK` ivLtz nte tm m`fÜ wi tcvU`KQymstKZ itqtQ, thgb-

- thtnZzGvU (gvb ubiÖZKiY e`e`v) GKvU AveiZ cÖqv Zvb uk¶K, KgrZP mKtj GtK GKvU evowZ Svtg jv gtb Kitz cvtib| mZivs evowZ Svtg jv Ask_ t jv memgqB Kvgtg tdj tz nte|

msL`vfvE`K chq jvPbvq AeZiY`ntj ubtgv` ubqvqKmg` mnvqK fvgKv cvj b Kitz cvti:

- mKj uk¶v_x`msL`v
- DExY`mZKt`i cÖB PvkZvi gvb
- uk¶K-uk¶v_x`AbgvZ
BZ`w`|

GB `wj tj uk¶v_xP mvveR Dbqtb i Dci mefaK `iazj Avtvc Kiv nqtQ| uk¶v_xP eqm, tRÜvi, FvIv, tFstMvj K Ae`vb, tckv mevKQ`K mePbvq AvbtZ nte| uk¶Y-ukLb KivR uk¶v_xP meZ`K mnthvMZv Kivi Rb` civgk` lqv nqtQ GB `wj tj | ejv nqtQ thb jvMmB chv` e`envi Kti uk¶v_xP ubtgv` me cKvii w`cwfK thvMthvMi mshvM cÖvb Kiv nq:

- uk¶v_xP`K`ti titL vUDUvis

ᚦ Ae GWKKkb

- ɪbɪeo gʃLɪgɪk Kɪhɪg
- GʷmɪBbʃgɪU KɪR cŏɪbgj-K ɪUDUɪs
- tɪgbUɪs ev cɪɪgkʰcŏɪvb
- ɪbʃʰ Rbɪ I mɪɪvɪhʰ cŏɪvb
- mɪncɪVɪ ʃj mɪɪvqK mɪv

ɪkʃɪv_xʰ ɪkLb mɪvqK mɪɪvɪgɪ i gʃaʰ _vKʃe ɪUDʃUɪɪ qɪj tKʃʰ ʃ ɪɪwɪfbɪɪʃʃZ mɪɪvɪ cŏɪvb Ges ɪkLb KɪʃRi Rbʰ ZɪʃK mɪiKg ɪkLb mɪgMŏ mɪeɪvɪ KiʃZ nʃe|

Avɪgɪv Avɪ ɪe ʃZ. Avʃj vPbɪq bɪ ɪMʃq hɪʰ cɪʃVi mɪvɪsk cŏʃZ Kɪɪ Zʃe ej e hɪʰ I "Total Quality Management" -Gi avɪYɪ ɪkɪKɪvɪLɪbɪv nʃZ MŏY Kɪv nʃqʃQ Zey AvɪR ɪekʃ Rʃo ɪkʃɪvɪ gɪvb ɪbɪwŏZKiY KɪʃR ɪɪwɪfbɪɪframework, ʰɪj j, ɪbqɪgK e ʰeüZ nʃʰQ| ɪkʃɪv tɪcŏMŏg cŏɪvbKɪvɪx cŏʃZŏvb ʰi ɪkʃɪv_xʰ mɪiKg Pɪvɪvɪ cŏʃZ j ʃʃ tɪʃL ʰi ɪkʃɪv tɪcŏMŏgɪ mɪ,ʃjv Ask cŏʃZ Kɪʃeb thb ɪkʃɪv_xʰZɪv KŏvɪRʃ mɪɪUɪɪʃKU cŏkʃbi gɪvʰg Zɪv Kgʃʃʃʃ Dchʃ Avɪb I ʰʃʃZɪv mɪʃ_ KɪR KiʃZ cɪʃi Ges Zɪv AvɪRʃ ɪɪMŏ, mɪɪUɪɪʃKU h_vʃhɪMʰ mɪʃʃb cɪq|

thʃnZzGKɪvKɪ tKɪvb ɪkʃɪv cŏʃZŏvʃbi cʃʃʃ GKɪU "framework" cŏʃZ Kɪv mɪgqɪʃcʃʃ Zɪv Avʰɪj Kʃvʃe mɪggbɪv cŏʃZŏvb,ʃjv GKɪUʃZ nʃq AvɪRKɪj GKɪU mɪvɪvY ʰɪj j cŏʃZi KɪRɪU Kʃi _vʃK Ges Gi ɪvɪʃʃZ mɪsɪkŏ cŏʃZŏvbmɪgʃɪ ɪkʃɪv tɪcŏMŏgmɪgʃɪ ʃ, YMZgɪvb ɪbɪwŏZKiY ɪbqʃʃʃ mɪʃe|



cɪʃVɪʃi gʃʰvqɪb 8.7

A) mɪʃʃʃB Dʃi cʃkæ

1. AAOU I COL-Gi DʃʰvʃM th ŏʰi ɪkʃɪvɪ gɪvb ɪbɪwŏZKiʃʃi Kɪvʃʃgɪwŏ cŏʃZ Kɪv nʃqʃQ Zɪv gʃ- Dʃʃʃkʰmɪgʃ ɪk ɪQj ?
2. cŏʃZKZ. ʰɪj ʃʃ tKɪvb ɪʰ K,ʃjvɪ cŏʃZ ʃ, iæZj Avʃi vɪc Kɪv nʃqʃQ?
3. ʃ, YMZgɪvb ɪbqʃʃʃʃi mɪL ɪvɪʃʃʃEK ɪbqɪgK,ʃjv Kɪ?
4. cʃʃʃʃi mɪvqZɪq ʰi ɪkʃɪvq ɪcɪvʃʃʃK thvMʃʃvʃʃMi mʃʃʃM iʃʃʃʃ tKɪvb tKɪvb tʃʃʃʃ?



Povšigj-iqb 8

A) msiŋB DEi cŋæ

1. D o g y i k L b K x ?
2. ` i - i k ŋ v i t g s i j K D c v ` v b K q u I K x K x ?
3. , Y M Z g v b e j t Z K x e s v q ?
4. t W r v u @ , Y M Z g v b e j t Z K x e s t q Q b ?
5. ` i - i k ŋ v i , Y M Z g v b i b u o Z K i t Y i m g K v j x b t K s k j , t j v K x ?
6. i k ŋ v i D t i k ` i b a f t Y i k L b m u x q D t i k ` K q u I K x K x ?
7. i k ŋ v i , Y M Z g v b i b u o Z K i t Y A u R D c v v t b i , i a z j e v L v K i a b |
8. j ŋ I D t i k ` i c v R ` D ` v n i Y m n A v t j v P b v K i a b |
9. D o g y i k ŋ v i o v i m e v i R b ` A e v m i Z - e v L v K i a b |
10. A v a n b K K v t j w e l q e ` P q t b t K v b w t K i c o Z , i a z t i v c K i v n q ?
11. D o g y I ` i - i k L t b m u u w Z e ` t c o m o g c e K v h @ t j v e Y o v K i a b |
12. i k ŋ v i , Y M Z g v b i b u o Z K i t Y i m s j K x ?
13. A A O U I C O L - G i D t ` i t M c o Z K Z . ` i - i k ŋ v i g v b i b u o Z K i Y ` u j t j t K v b w K , t j v i D c i c l a v b ` t ` l q v n t q t Q ?
14. ` i - i k ŋ v i q c h i y i m n v q Z v u o c w ŋ K t h v M v t h v t M i m s h v M i t q t Q t K v b t K v b t ŋ t i ?

A v) i P b v g j - K c ŋ æ

1. ` i - i k ŋ v I D o g y i k L t b i c v R ` u j L b | D o g y i k L t b i k L b m i g M o i K v R e Y o v K i a b |
2. D o g y i k L b I ` i - i k ŋ v i , Y M Z g v b m s i ŋ t Y i c h i q m g r A v t j v P b v K i a b |
3. ` i - i k ŋ v i , Y M Z g v b i b u o Z K i t Y i A v a n b K t K s k j m g r A v t j v P b v K i a b |
4. i k ŋ v i , Y M Z g v b i b u o Z K i t Y m v g m R K , A _ o w Z K I i v R _ o w Z K t c o ŋ v c U w e k ` f v t e A v t j v P b v K i a b |
5. ` i - i k L t b i k ŋ v i u g e v ` e v q t b i K v h @ e Y o v K i a b |
6. ` i - i k L t b , Y M Z g v b i b u o Z K i t Y i g v b ` U A v t j v P b v K i a b |
7. D o g y i k L b I ` i - i k ŋ v i q i k ŋ v i x m n v q Z v t m e v i c h i q , t j v i w e e i Y w ` b |

Dəgəy əkLb I `i-əkŋvi gub ibı̄ðZKiY Bmÿ mġm'v I fıel'r w̄ K ıbt`Rbv

[Quality Assurance in Open Learning and Distance Education: Issues, Problems and Future Direction]

fıgKv

`i-əkŋvi ,YMZgub ibı̄ðZKiYi mıt_ Rıoıq Avıq weıfbæw̄ K, thgb- tckıMZ tbZZı Av`kAe`v, gub`Ü BZ`w̄ | `i-əkŋvi ,YMZgub ibı̄ðZKiYi tŋŋı̄ Avı I w̄KQıw̄ K ıtqıQ th_ıjv mıtÜ Avııı i meıBıK Mfıı fııte w̄PŞıfıevı KıtZ nıe| tm_ıjv nj - (1) `i-əkŋv mıtÜıq Bmÿ (2) mġm'v I (3) fıel'r w̄ K ıbt`Rbv|

eZgıv BDıbtU `i-əkŋvi gub ibı̄ðZKiY mıtÜıq AvıııPbv ıbtgıe³ cıııU cıııVı gıa`ıg Dc`ıcb Kıv nıtqıQ|

- cW 9.1 t `i-əkŋvi gub ibı̄ðZKiY mıtÜıq Bmÿ-1
- cW 9.2 t `i-əkŋvi gub ibı̄ðZKiY mıtÜıq Bmÿ-2
- cW 9.3 t `i-əkŋvi gub ibı̄ðZKiYi mġm'v
- cW 9.4 t `i-əkŋvi ,YMZgub ibı̄ðZKiYi MııZavıv Ges fıel`Z w̄ K ıbt`Rbv
- cW 9.5 t weıtkı Dııııııı I Dııııııı kmgııııı Aııııııı w̄ ıbtı `i-əkŋvi w̄ K ıbt`Rbv

cW 9.1

`f-ikqivi gvb wbuDZKiY m`Uxq Bmÿ 1

[Issues of Quality Assurance in Distance Education- 1]

Df`ik`

GB cW tkfI Avicwb –

- `f-ikqivi Df`ik` wbañY m`Uxq Bmÿ,tj v weeZ KiTZ cvi teb;
- `f-ikqivq wewfbañi tbi ig_w`eqv m`Uxq Bmÿ,tj v Dfj L KiTZ cvi teb;
- `f-ikqivi m`ZmZm` (critical) Bmÿ,tj v e`vL`v KiTZ cvi teb Ges
- `f-ikqivi gE` Bmÿ,tj v (key issues) eY`v KiTZ cvi teb/

Df`ik` wbañY m`Uxq Bmÿ

Dsgj wklb l `f-ikqivi ,YMZgvb wbuDZ KiTZ ntj Df`ik` wbañY m`Uxq Bmÿ,tj v chñj vPbv Kiv `iKvi | Df`ik` m`Uxq Bmÿ,tj vtK wbgñfc e`vL`v Kiv hvq:

Df`ik` m`Uxq Bmÿ

- **ikqivi m`hvm** (Access): Dbqbkj wtk! c`q mKj ikqiv `fi m`hvm evovtovi e`e`v_vKtZ nte/
- **ikqivi e`q** (Cost): m`u` m`wZ ntj l th tKvb t`tki ikqivi m`hvm ewxi mvt_e`tqi GKil m`uK`vtK | Gw Dbqbkj t`tki D`P ikqivi t`qf`i wtkl fite c`Yavb`hvm`/
- **YMZgvb** (Quality): hLb ikqivi m`hvm ewx civq Ges ikqiv-wklb c`vMZ c`xwZ e`eüZ nq ZLb ikqivi ,YMZgvb msi q`fYi S`k ewx civq/
- **bgbnqZv** (Flexibility):D`P ikqivi t`qf`i h`mi `wetZ ikqiv_xP AvR` Avf`AZv l Pwv`v w`b w`b ewx civq/ ZvB `qZv AR`bi Rb` ikqiv jvtfi m`t` m`t` Riebe`vcx c`kqY M`Y Acwi nvh`ñtq cto/
- **beZi D`weZ** (Innovation): beZi D`weZ Kj vtK`kj wklb eüglx Df`ik` AR`bi MwZ Zi w`SZKiY c`qvm KiTj fij dj cvl qv hvq/

Dctiv` Bmÿ,tj v m`uq wetePbv Kiv GKv`c`qvRb/

wefbñi tbi ig_w`eqv m`Uxq Bmÿ

`f-ikqivi DIvj tMe`j avi Yv wntmte `f-Z; ikqiv_xP `faxZv Ges ig_w`eqv -GB wZbw c` e`eüZ nq/ cieZx`Kvtj gj (84), mvev, wKMvb tmj (88) ig_w`eqv ev interaction Gi wefbw` K m`u`K`e`vL`v c`v b Kt`b/

AZci "Interaction : That Perplexing Component of Distance Education" kxl` c`vtbj Avtj vPbv gva`tg Avb` wmmvj , Gtj b tfMbv, Gb BDwq qvq 1989 mvtj

RbMYI G w k q v t t k j v f e v b n t Z c v i t Q | G i j c c w i e n Z Z t c q v c t U i w k q v
D b q t b i w u u k i j B m y t j v n j :

Critical issues

- Conventional education will maintain its position as the mainstream form of provision. Advanced technology will make in roads into traditional instruction. A significant proportion of instruction in higher education on campus will be carried on through information technology in addition to the face-to-face oral interaction process. Gradually, there will be an increasing convergence between conventional and distance education. Eventually, conventional instruction will evolve from a pre-industrial (handicraft) form to a post-industrial form (information technology intensive with high levels of academic responsibility and a learner-centred approach).
- All distance education systems need to improve further in the open learning dimension, that is, to make continuing efforts not only in openness and equity of access, but also in openness and flexibility of teaching and learning. Conventional education institutions can also make a great contribution in developing open learning initiatives. They may offer open learning courses independently, jointly and / or collaboratively with distance education provider. Open learning will be the most significant development in the sector of continuing education and in-service training.
- Distance teaching universities will continue to develop early in the next century. However, for most dual-mode universities, distance education or off-campus studies will continue to be treated as second rate by the institutions and as a marginal job by academic staff. Most campus-based universities, especially the best-known ones, will not convert themselves into dual-mode universities. Nevertheless, there will be a growth in the number of campus-based universities converted into dual-mode universities, and an increasing number of dual-mode universities where on-campus and off campus studies operate in an integrated way. In the next century, distance teaching universities, dual-mode universities and various kinds of multi-institutional models of provision will face more competition, and will need more collaboration in forming various national systems and in becoming part of the globalisation process.

[e v s j v A b q t g j f v e e m s i q y K i v h t o K w b n t e g t b K t i D c t i v 3 A s k U K z
B s t i w R t z Z t j a i v n j]

i w k q v i g l B m y

i w k q v i g l B m y t j v t k G K v t W w g K w o t K v Y t t k w e P v i w e t k d Y K i t j e j v h v q t h,
this covers the various forms of study at all levels which are not under the continuous, immediate supervision of tutors present with their students in lecture rooms or on the same premises.

cW 9.2

`i-uk`ivi gvb ubiDZKiY m`Uxq Bmÿ 2

[Issues of Quality Assurance in Distance Education- 2]

D`ik`

GB cW tk`I Avicwb-

- `i-uk`ivi tKvm`Dbq`b m`Uxq c`avb Bmÿ,tj v weZ Ki`Z cvi`teb;
- tKv`tmP` ukLb mvgM`Drcv`b (gy`Y) m`Uxq Bmÿ,tj v D`j`L Ki`Z cvi`teb;
- tKvm`mvgM`D weZiY m`u`u`KZ Bmÿ,tj v e`vL`v Ki`Z cvi`teb;
- uk`ivi_x`m`Uxq BmÿKx Kx Zv eY`v Ki`Z cvi`teb ;
- uk`ivi_x`m`nvgZv tmev we`l`qK Bmÿ,tj v avi`v`m`Kf`v`te weZ Ki`Z cvi`teb ;
- ugv`Wqv we`l`qK BmÿKx Kx Zv ej`Z cvi`teb|

we`l`qe`-`cvi`v`Pv`Z

`i-uk`ivi , YMZ gvb ubiDZKiY m`Uxq we`f`b`w`ai`t`bi Bmÿm`u`u`K`uk`ivi`we`MY ukQy , iaz`c`y`w`K ubt`Rbv c`v`b K`i`t`Q`b| BD`b`b`-v KZ`R Av`t`q`v`RZ (1990) `i-uk`ivi , YMZ gvb ubiDZKiY e`e`-v`c`b`v K`g`k`w`e`t`i thv`M`v`b`K`v`x we`t`k`I`A`M`Y`G uk`ivi e`e`-v`c`b`v cv`i`P`j`bv Ki`Z w`M`t`q`K`x`K`x Bmÿj`i c`Z , iaz`j`c`v`b K`i`v`i`c`q`v`R`b Zv w`P`v`y`Z K`i`t`Q`b| GB Bmÿj`i c`avb c`avb w`K`nj -

uk`ivi`u`g`m`n tKvm`Dbq`b, ukLb mvgM`D gy`Y, ukLb mvgM`D weZiY, uk`ivi_x`m`nvgZv tmev, ugv`Wqv BZ`w` | Gme Bmÿj`i we`f`b`w` K m`u`u`K`GB cv`v` Av`j`v`K`c`v`Z K`i`v`nj :

tKvm`Dbq`b m`Uxq Bmÿ

`i-uk`ivi , YMZ gvb Dbq`t`bi Rb` th me Bmÿ`c`v`i`e`x`Y`Y K`i`v`n`j ubiDZ gvb Dbq`z n`te`e`j Av`k`v` K`i`v`h`v`q`Z`v`nj -

- tKv`b`G`j`v`K`v`q` tKv`b`a`i`t`bi tKv`tm`P` P`w`n`v`i`t`q`t`Q`Z`v`M`t`e`l`Y`v`i`g`v`a`t`g`w`P`v`y`Z`K`i`t`Y`i`e`e`-v`K`i`v`;
- c`q`v`R`b`I`P`w`n`v`i`w`f`w`E`t`Z` tKv`tm`P`c`v`i`m`i`w`b`a`f`Y`;
- c`Z`K`i`w` tKv`tm`P` P`w`n`v`A`b`h`v`q`x`we`l`qe`-`w`b`a`f`Y`;
- h`u`i`v`G`me` tKvm`c`v`q`b`K`i`te`b`Z`u`i`v`G`K`v`t`W`i`g`K`w`K`w`t`q`K`Z`U`K`z`thv`M`Z`v`w`e`P`v`i`K`i`Y`;
- ukLb mvgM`Di`G`K`v`t`W`i`g`K`I`uk`ivi`M`Z` (pedagogic) gvb m`u`u`K`w`e`t`k`I`A`M`t`Y`i`A`w`f`g`Z`R`i`v`v`;
- tKvm`mvgM`Di`m`u`u`U`U`D`U`i`M`t`Y`i`A`w`f`g`Z`m`u`u`K`R`i`v`v`;
- tKvm`mvgM`Di`D`ch`y`Z`v`m`u`u`K`uk`ivi_x`K`x`A`w`f`g`Z`c`v`b`K`i`t`Q`Z`v`ch`j`j`v`P`b`v`K`i`v`;
- c`Y`x`Z` tKvm`mvgM`Di`u`g`v`W`q`v`i`g`v`a`t`g`D`c`-v`c`t`bi`R`b`ch`f`B`w`K`b`v`Z`v`h`v`P`v`B`t`q`i`R`b`w`e`P`v`i`w`e`t`k`I`Y`K`i`t`L`v`|

Drcv`b wElqK Bmÿ

- ֿ YMZ gubm=ubawkLb mvgM0 Drcv`b Kiv ntqtQ wK bv Zv wPvi wtkdY Kti t`Lv ;
- ֿ 7 cKvkbv c0Z0vfb wKlb mvgM0 Drcv`b Kiv nq wK bv Zv t`Lv ;
- ֿ ֿ wK7vi mvgM0 wtklA I KgrP gva`tg c0qb Kiv ntqtQ wK bv Zv t`Lv ;
- wKlb mvgM0 Drcv`b tKvb aitbi Avf`šliXY I ewn`K mšhVM mÿav e`envi Kiv ntqtQ Zv t`Lv Ges
- Avf`šliXY I ewn`K mšhVM mÿav e`envi Zÿbvqj-Kfiſe ֿ YMZgub wK ti tL tKvbUli LiP Kg ev teik ntqtQ Zv hvPvB Kti t`Lv|

wEziY m=0xq Bmÿ

- h_vmgſq, mWk wKvbwq, ֿ YMZ gubm=ubawkLb mvgM0 tc0Y Kiv ntqtQ wKbv Zv wbu0Z Kiv|
- evfRU eivfi i gta` wKlb mvgM0 tc0Y Kiv m=0 ntqtQ wK bv Zv wbx7v Kiv|
- cwi Kf bv Abſvqx wKlb mvgM0 wEziY Kiv ntqtQ wK bv Ges e`wZµg ntj Zvi KviY Kx Zv LwZſq t`Lv|
- wKlb mvgM0 wEziY tKvbifc AšliVq ntj Zv wKfiſe DEiY Kiv ntqtQ Ges fiel`Z thb Giſc bv NſU Zvi Rb` Kx e`e`v M0Y Kiv nte tmU wbaſY Kiv ntqtQ wK bv Zv ceſſyB t`Lv|

wK7v_xwElqK Bmÿ

- j 7` ֿ tji KZ Astki Rb` tKvb tKvb tc0M0g I tKvm0eZ0vfb c0vb Kiv nt`Q Zvi wmwve ivLv|
- ֿ ֿ wKlfb KZ j 7`gvſv wbaſY Kiv ntqUj Ges Zvi KZ AskſK G wK7v e`e`vq Avbv m=0 ntqtQ Zv Rvbv Ges wKfiſe Aewk0ſK Avbv hvq Zvi e`e`vKiſYi Dſ`vM wKifc ?
- wK7v_xKZſ tKvm0m=0xq Abſv0vb wElſq KZ msL`K Avſe`b cvl qv tMſQ Ges Zv wKfiſe tgUvfbv ntqtQ Zv hvPvB Kti t`Lv|
- Avſe`bKviſt`i msL`v KZ wQj Ges Zvi gta` KZRbſK fiwZ`Kiv ntqtQ?
- tKvm0ſſEK Sſi covi nvi KZ? Gi KviY Kx Kx Zv wbx7v Kti t`Lv|
- ce0hVMſhVM e`e`vi gva`tg avivewnK gubUwiS Kti wK7v_xP AM0wZ hvPvB Kiv ntqtQ wK bv, Avi Zv Kiv ntj wcuQſq covi KviY wPvſyZ Kiv ntqtQ wK bv Zv hvPvB Kiv|
- wK7v_xP cvſmi nvi wKifc Zv wbx7v Kti t`Lv|
- wK7v_xP tKvm0ngvwiBi nvi KZ Zv hvPvB Kiv|

tmev m=0xq Bmÿ

- c0qvRb I Pwin`vi Zÿbvq wK7v_xP mrvqZv tmev c0vſbi e`wB KZUKZZv Rivvi Rb` Kx aitbi e`e`v itqtQ ?
- chſB I mWk Z` wſt` wKvi gva`tg Rivvſbvi wKifc e`e`v itqtQ Zv wbx7v Kti t`Lv|
- KZ kZvsk wK7v_xGB mrvqZv tctq_vſK ?

- cŷ, tUij tdivtb, eiv³MZfvte `z I avivemK me aitbi Abyŷŷtbi DĒi cŷtbi e`e`v|
- mŷK I h_vh_ Z_` mKj tK AemZKi tYi e`e`v|
- mŷKfvte ŷkŷv_xp mKj aitbi Zt_i tiKW©ivLv nq ŷKbv Zv Rŷvri e`e`v Kiv|
- ŷbaŷi Z mgŷqi gŷa` ŷkŷv_xp ŷbaŷi Z KvR (assignment) mŷŷxq Z_` hvPvBŷqi e`e`v|
- ŷkŷv_xp ŷbaŷi Z KvR mŷŷtK©UDUiM tYi gŷŷe`i ŷ, YMZgŷb ŷKŷc Zv Rŷvri e`e`v|
- tmev mŷŷtK©ŷkŷv_xp Awf thvM wektid Y Kti t`Lvi e`e`v ŷKŷc ?
- ŷ, YMZ I ŷkŷvMZ gŷbmŷbŷbaUDUi ŷbŷqŷM e`e`v hvPvBKŷi Y tKŷkj |
- KZ kZvsk ŷUDUi cŷkŷŷY e`e`vq thvM`vb Ktib Ges Zviv KZ fvte ŷJDtUŷis (tutoring) Kti ŷvŷKb Zv t`Lvi e`e`v|

ŷgŷŷqv Bmŷ

- h_vh_ ŷelq ŷbaŷi Y I Dchŷ ŷkŷŷK KZŷ ŷŷv I tiŷŷI-Gi gŷa`tg cvV Dc`vcb e`e`v|
- ŷŷv I tiŷŷI tŷŷŷgmgŷ Awakvsk ŷkŷv_xp Pŷvŷ`vgŷvdK mgŷq cŷi tŷkb mŷŷxq e`e`v hvPvB Kiv|
- ŷkŷv_xp Avte` tbi ŷfŷŷtZ tKvb ŷelq ŷŷv tŷŷŷg Dc`vcbKi tYi e`e`v|
- ŷŷv I tiŷŷI -Gi tŷŷŷg tKvb Zŷi tL, KLb, tKvb ŷelq cŷi tŷkb Kiv nŷe Zv ŷkŷv_xpK ceŷŷy AemZKi Y e`e`v|



cŷtVĒi gj`vqb 9.2

A) mŷŷŷB DĒi cŷæ

1. tKŷmŷDbŷb mŷŷxq BmŷKx Kx?
2. Dŷj ŷLZ tKŷmŷDrcv`b mŷŷxq BmŷQrov Avcbri gŷZ Avi Kx Kx Bmŷmshŷ nŷZ cŷi Zv ŷj Lŷ|
3. tKŷmŷvgMŷ ŷeZi tYi Kŷhŷ` ZivŷŷZKi tY Avcbri civgk©Kx Kx?
4. ŷkŷv_xp mŷŷxq Acivci BmŷKx nŷZ cŷi Zv ŷj Lŷ|
5. ŷkŷv_xp mŷŷxq tmev tRvi`vi Ki tY Avcbri civgk©Kx Kx?
6. ŷgŷŷqv ŷelqK BmŷKx Kx nŷZ cŷi Zvi GKŷJ Zŷij Kv ŷ`b|

ideas are submitted to the demands of their colleagues and collaborators, with whom they may not be in full agreement. Sometimes power battles occur which may lead to serious confrontation.

- `i-ukŕŕv e`e`v th#nZzGKiu `tj i KVR tm#nZzGi mmeŕ `vqZj Kvi- G ub#q `tj i m`m`i gta` 0:0 t`Lv hvq| GQvovl AvgjvZvmsŕK RiuJ Zvi Rb` eü Kv#Ri mgvartb mgm`v t`Lv hvq|
- wgvWqv cvV cÜZKi#Yi mvt_ msuk0 _v#K `ŕ ev d`vKvè, tcÜMg, welqe` ; ukŕŕK, Dc`vcK, cÜhVRK, K`vtgiv, m`úv`bv Ges Avil ukQychnyßMZ w`K| Gt`i gta` mgš#qi Afvte mgm`v m#0 nq|
- ukŕŕvµg t_#K iiaKti cixŕŕvi dj cŕvK chšl mKj avci , YMZgvb msiŕŕY l DbwZKiYRwbZ eü mgm`v l m#0 nq|

evn`K mgm`v

- c#eB ejv ntqtQ th, `i-ukŕŕvi evn`K mgm`v, tjv tckv msuk0 mgm`v| `i-ukŕŕv e`e`vq eü msL`K ukŕŕv_xŕK Btj KUwbK wgvWqv gva`tg ukŕŕv`vb Kiv m#e| `i-ukŕŕv e`e`vq ukŕŕv`v#b GKRB ukŕŕK#K RmZi mvg#b Dciv`Z ntZ nq| tm Rb` th tKvb tQvULvU ŐwLi Rb` RbZvi mgvtj vPbvi m#0vb ntZ nq hv cÜvMZ ukŕŕv`v#b KLbl nq bv|
- `i-ukŕŕvi Aci GKiu evn`K mgm`v nj - `i-ukŕŕv tKej ukŕŕv`v#bi gva`B mgvex (pedagogical product) bq, eis Gi cŕve mgv#Ri Dci l cto|
- `i-ukŕŕv e`e`v ukŕŕv Mh#Y B`Qŕ eümsL`K e`wß#K ukŕŕv jv#fi m#hvm cÜvb Kti| ukš` , YMZgvb hv#Z ŕŕ#ebv nq tmw`#K j ŕŕ ivL#Z nq| Kvi Y Gi , YMZ gv#bi m#½ evn`K w`#Ki msuk0Zv i#qtQ|
- `i-ukŕŕvi Aci mgm`vWJ nj ukŕŕv_xŕmrvqZv tmev welqK mgm`v|
- ukŕŕv_xŕ i ukŕŕv cÜZv#b KgŕZ gj- ukŕŕ#Ki m#½ Avtj vPbvq mi vmi AskMh#Yi m#hvm L#B mxvgZ -GiUl `i-ukŕŕvi GKiu Ab`Zg mgm`v|

`i-ukŕŕv e`e`vq ukŕŕK-ukŕŕv_xŕm#úK`cÜvMZ ukŕŕve`e`v A#cŕŕv RiuJ

AvcvZ`w#Z mivmi thvM#hvm Kg n l qv m#Ej| `i-ukŕŕv e`e`vq ukŕŕK-ukŕŕv_xŕ m#úK`cÜvMZ ukŕŕv A#cŕŕv RiuJ | `i-ukŕŕvq ukŕŕv_xŕ thvM#hvm wbg#ŕc ntq _v#K:

`i ukŕŕvq thvM#hvm cŕµqv

1. **`i ukŕŕY cÜZv#bi mvt_ thvM#hvm:** `i ukŕŕY cÜZv#bi mvt_ ukŕŕv_xŕ cŕvmbK, fiv, tKv#mŕ RiuJ Zvmsµvšl GKv#WgK cigk`ev mivh`, gj`vqb cŕµqv, cixŕŕvi djvdj cŕvK wel#q thvM#hvm nq| ukš` cÜvMZ cÜZv#b thvM#hvm nq cÜZv`b|
2. **ukLb mgM#i** ukŕŕv_xŕ tcÜYv, ukLb-tKlv#bv tKškj, gj`vqb cŕµqv, ukŕŕv`vb c#vZ Avyiy BZ`w` ukŕŕY cŕµqv#K cŕveZ Kti cÜZv#b KgŕZ gj- ukŕŕKe, , ukŕŕv_xŕ ukLb mgM#i gta` m#úK`vcb Kti _v#K|

- ukŷv_xP Avw_Ŕ mŷgve×Zvi KviŷY Btj KUŷbK ugwWqv e`envt̄i i mŷhVM AZ`šl mŷwZ|
- j ŷŷ`tj i Rb` ugwWqv mrvqZv Achŷŷ|
- wDUi ev LŪKvj xb ukŷŷK, ukŷŷv_xŲ MvRxcj K`v=úvŷm KgŷZ gj- Abyŷ` i gŷa` thvMmŷ ŷvcb e`e`v Avkvbjŷc Kvhŷi bq|
- weŷfbæcŷkvmibK weŷvM I Abyŷ` i gŷa` mgšŷ Avkvbjŷc bq|
- cixŷv weŷvŷM chŷŷ I `ŷ Rbkw`i Afvŷe dj cŷKvk wej wŷZ nq| Gi mvŷ_ RiwZ iŷqŷQ Dchŷ Kw=úDUvi mdŷl q`vŷi i Afve|
- Achŷŷ I Kvhŷi gubUvis -Gi Afvŷe fivZ`ibaŷi Z mgŷq mgvŷ Kiv m=ŷe nŷ`Q bv| `i- ukŷŷv_xP Avw_Ŕ Ae`v chŷŷj vPbv Kiŷj ŷ`Lv hvq gvŷVi dmj Nŷi Zŷŷj ZŷeB Zvi v Awakvsk ŷŷŷŷ fivZ`id w`ŷZ mŷŷg nq|
- gj- mgm`v mbv` Kŷi `ŷZ mgvarb LŷR tei Kivi gZ AwfÁZv Ges `ŷŷZvi Afvŷe mŷgMŷK Kvhŷŷg e`vnZ nŷ`Q|
- Kvhŷi tcŷYvgj-K tcŷMŷg mŷwZ weavq tckvMZ gvŷ ew× e`vnZ nŷ`Q, cwi Yvŷg KvŷRi AŷxKvi nvm cvŷ`Q|



cvŷVvŷi gj`vqb 9.3

A) mŷwŷŷ DEi cŷæ

1. `i- ukŷŷvi mgm`v KZ aiŷbi I Kx Kx?
2. Avf`šŷi xY I evn`K mgm`vi wŷwEMZ cv_Ŕ` Kx?
3. `i- ukŷŷvi ŷKvmŷwRvBb cŷŷqŷbi bŷwZ wKifc?
4. `i- ukŷŷvq ugwWqv Drcv`ŷb Kvi v mŷwŷŷ `vŷKb?
5. `i- ukŷŷvi evn`K mgm`v Kx Kx?
6. `i- ukŷŷvq ukŷŷK ukŷŷv_xŲm=úK`cŷvMZ ukŷŷv Aŷcŷŷv Riwj ŷKb?
7. Dbæbkjŷ ŷ`ŷki `i- ukŷŷvi mrvavi Y mgm`v Kx Kx?

Av) iPbvŷj-K cŷæ

1. `i- ukŷŷvi mgm`vi ŷKŷweŷvM Dŷj Lceŷ cŷZ`Kwŷi `ewkó` weeZ Kiab|
2. ŷŷ`i- ukŷŷvq ukŷŷK-ukŷŷv_xŲm=úK`Riwj ŷŷ- Zv Pviwŷ D`vniŷYi gvaŷg e`vL`v Kiab|
3. Dbæbkjŷ ŷ`ŷki mrvavi Y mgm`vmn ersj vt`ŷki `i- ukŷŷvi gj- mgm`v ŷjvi weeY w`b|

that would reach every nook and corner of India. The Indian network system reaching every village and telephone terminal is therefore essential for giving access to everyone. The universities have to undertake a major programme of 'packaging', the expertise and knowledge of the best teachers in multi-media-integrated and separate for offering it to learners of diversified backgrounds. Since the numbers to be reached are quite large and scattered, broadcasting facilities for access to the masses would be necessary for every regional language. In future, a university can run its university-wide 'class-room' for all its students. In fact development of Knowledge or Education and Training Network (OPENNET) for all should be our immediate goal.

During the IXth Five Year Plan, the education sector should try to :

- Develop OPENNET providing access and the flexible use of information communication network to all educational institutions in India as a national facility.
- Jointly develop high quality multi-media programmes useful for multi-channel learning in all areas of knowledge and in particular in professional, technological and vocational areas.
- Promote CT use and development of 'Resource Centers' and Multi-media-Learning Centers in all parts of India for giving wider access to all learners.
- Establish partnership with industries and various organisations and institutions for offering training and retraining of personnel in and around the industry and institutions. Undertake programmes of transforming existing print knowledge into user friendly electronic storages to be made accessible through nodes of networks.
- Undertake training and development programmes to develop expertise to use and maintain CTs.
- Undertake research and development programmes to promote application of CT in education and development of educational technologies.
- Adopt policies and programmes for ensuring equity, access and success for all, particularly for the disadvantaged learners.
- Develop DEC and NAAC to function as Accrediting and Quality Assessment bodies for all programmes / courses put in the OPENNET.
- Adopt and implement all measures initiated by DEC such as Credit Transfer, Grading System, Common Pool Programmes, Sharing of 'Resource Centers' (SRC) etc. for network development.
- Take the support of Commonwealth of Learning (COL) to ensure the quality of programmes for sharing them at the international level.

Since the technologies and their adoption are changing rapidly, it will be rather difficult to have long-term programmes. But the measures proposed above may put higher education of India on the world map capable of solving the problem of educating millions and creating foundation for developing knowledge based society.

evsjv`k I tcb BDwbffmUj Amlhgxw`tbi Kvhpg

evsjv`k I tcb BDwbffmUj D>gY I `t- wkl`tbi , YMZgvb wbu`ZKiYmn Acivci th me Kvhpg MhY Kti`Q Zv nj :

D>gY wkl`vi Uvi mevi Rb` Aewi Z

- wkl`K I KgRZMAY`K eZgub D>gY I `t- wkl`tbi Muzaviv m`fU Pvk`xKvj xb AwfAZv jv`fi Rb` we`tk c`k`q`tyi e`e`v Kiv n`q`Q|
- Commonwealth Educational Media Centre for Central Asia (CEMCA) -Gi gva`tg ugwWqv t`m`w`k`k`b m`fU evDwe`i we`f`be`-`t`j`i wkl`Ke,` I msuk`w KgRZ` i c`k`q`y `vb Kiv n`q`Q|
- Kgbl`t`j`_ Ae j`wb` (COL) -Gi mnvqZvq evsjv`k I tcb BDwbffmUj`t`Z GKiu` t`U`bs I M`tel`Yv` t`K` `a` `t`c`t`bi D`f` `v`M MpxZ n`q`Q| GB t`K` `f` gva`tg t`k`-we`f` t`ki msuk`w e`w`e`m`K I tcb I `t- wkl`tbi we`f`be`w`el`q I w`K m`fU c`k`q`y `vb I M`tel`Yv Kiv n`te|
- Kgbl`t`j`_ Ae j`wb`-Gi mnvqZvq evsjv`k I tcb BDwbffmUj 2002 mvj t`t`K `t` Ae we`R`t`bm -Gi Z`E`ye`a`t`b -
 (1) Commonwealth Executive Master of Business Administration Ges
 (2) Commonwealth Executive Public Administration - k`xl`R `w`j t`c`m`w`g c`e`Z`b Kiv n`q`Q|
- G`_t`j`v e`Z`x`Z evsjv`k D>gY we`k`je` `v`j`t`qi GKv`w`w`g`K t`c`m`w`g`i , YMZgvb ew`x`i j`t`q`l` w`b`t`a`w` w` K`_t`j`vi c`w`Z` h`_`v`h`_ , i`a`z`j`c`w`vb Kiv n`f`Q:

1. Equivalence of Degrees and Diplomas

Questions have been raised from different quarters regarding the equivalence of the degrees offered through distance education programmes with the corresponding degrees offered through conventional educational programmes. This skeptic attitude manifests a mind-set to disregard any innovation whatever merit or vision it may possess. However studies may be conducted to eliminate the shortcomings of Distance Education through deep comparative analysis of the two types of programmes.

2. Ensuring effective students supports service

Students enrolled in the distance education programme are scattered all over the country. They have problems which call for administrative measures and queries which require academic attention. Existing facilities can hardly provide desired guidance and counselling to the students as and when they need it. Extensive effective infrastructure development and extension of network is the immediate need to solve the problem.

3. Increasing contact hour

Increasing teacher-student contact hours has far reaching effect in ensuring quality of education. Distance education learners are mostly youths employed in different sectors of the economy. Therefore it is very difficult to determine an optimum level of contact hours and to evolve effective procedure of contact.

4. Shortage of efficient manpower

Distance education is a new approach to the management of education. Administrative management personnel and academics with enriched ideas and experiences of distance education are not sufficient enough. This is a hard problem for developing countries aspiring to fulfill the mandate for achieving "Education for All".

[Dřj l` Dcřiv³ gšė`mgn AvšR@ZK `i` ikřv mekři`ři huiv evDřeđi ikřv Kihřig AZ`šřm² řiře chřj vřbvi `vqřZ; vřtqvrZ vřQřj b |]

evsj vř`k Dvgř mekře`ij q thřnZZAsian Association of Open Universities (AAOU) -Gi m`m` tmřnZzGB mekře`ij q vřvřbėDř`vM MřY KiřQ thb 2002 mřřj AAOU cřZKZ. "Quality Framework"-Gi cřvgk` Abřvřři ikřv řcřMřg řjvi vřvřbėv řKi ř YMZ gřv iřřv KiřZ ev mğřv KiřZ mřřg nq|



cřřvřři gř`vqb 9.4

A) iřbřgř-K cřkė

1. `i` ikřřři ř YMZ gřv vřvřřZKiřY Bř`iv Mřřx I řcb BDřbřřmřř Avřvgř vř řbi Kř c`řřc MřY KiřQ Zř vř Lř|
2. evsj vř`k I řcb BDřbřřmřř Avřvgř vř řbi Rb` Kř Kř c`řřc MřY KiřQ Zř vř vřvř Kiřb|

ሪፖርት 9.5

የደንበኞች ልምድ የሚታይ ለሥራ ለማድረግ ወይም ለሌሎች ለማድረግ

[Future Directions of Distance Education in Developing and Developed Countries]

ጥያቄ

GB ሪፖርት ላይ

- የደንበኞች ልምድ የሚታይ ለሥራ ለማድረግ ወይም ለሌሎች ለማድረግ ይኖር የሚችል ለማድረግ ይቻላል
- ለሥራ ለማድረግ ወይም ለሌሎች ለማድረግ ለሚያስችል ለማድረግ ይቻላል

[የደንበኞች ልምድ: GB ሪፖርት ላይ አጠቃላይ ለሚገኝ ለሥራ ለማድረግ ወይም ለሌሎች ለማድረግ]

የደንበኞች ልምድ የሚታይ ለሥራ ለማድረግ ወይም ለሌሎች ለማድረግ

የግብርና ስራ ለማድረግ ለሚያስችል ለማድረግ ይቻላል የሚለውን ለማሳሰብ

የሥራ ለማድረግ ለሚያስችል ለማድረግ

1980 ለሥራ ለማድረግ ለሚያስችል ለማድረግ ይቻላል የሚለውን ለማሳሰብ

የሥራ ለማድረግ ለሚያስችል ለማድረግ ይቻላል የሚለውን ለማሳሰብ

Category 1 : Correspondence-based distance education

- Correspondence study based on print materials supported by audiotapes and / or videotapes (higher interaction)
- Correspondence study based on print materials supported by broadcast signals (radio or television) but with no 'real-time' communication
- Correspondence study based on print materials only (lower interaction)

Category 2 : Telecommunication-based distance education

- Two-way voice link, two-way video (full-motion) link (higher interaction)
- Two-way voice link, two-way video (freeze frame) link
- Two-way voice link, one-way video (full-motion) link
- Two-way voice link, one-way video (freeze frame) link
- Two-way voice link only (lower interaction)

Avj űgv BKeyj I t̄cb BDibfűmű (AIOU)

cűűK`l̄t̄bi Avj űgv BKeyj D>gŷ űekje`ij t̄q űkűűY-tkLv̄t̄bv cűűűűű eZűűt̄b th me ű K mst̄hűM Kiv n̄t̄q̄ű t̄m, t̄j v nj :

- Systematic study of correspondence texts by students at their homes.
- Regular hearing and viewing facilities of radio and TV lessons at study centre.
- Contact with tutors at study centres.
- Written assignments.
- Final written examination.
- Practical work with special home experiment kits.

BDt̄iűt̄ci t̄`kmḡt̄a `i-űkLb

hŷivR`mn BDt̄iűt̄ci AűűKűsk t̄`k `i-űkLb cűűvbZ űZb aīt̄bi t̄Kűm@cűűvb Kt̄i űűt̄K/ űb̄t̄P Gt̄`i `en̄kű D̄t̄j L Kiv nj :

- The current primarily text-based courses, but with greater use of electronic publishing.
- Lecture-based courses, using cable-satellite or video cassette-based technology, supplemented by set of reading materials.
- Electronic courses, using the telephone and electronic communication with limited textual support, interaction between tutors and students on going basis.

`i-űkLb cűűŷ I űűűűűű e`envi

(a) Distance education technologies (two-way communication)

1. Correspondence (First Generation)
 Message : Print
 Delivery Mode : Mail
 Instructional Method : Individual
2. Teleconferencing (Second Generation)
 Message : Audio/Video/Computer
 Delivery Mode : Telecommunications
 Instructional Method : Group

ḡ Ae GwKkb

3. Computer-based (Third Generation)
Message : Audio/Video
Delivery Mode : Telecommunications / Micro-processor
Instructional Method : Individual

(b) Ancillary media in distance education (one-way communication)

1. Print materials
2. Audio / Video-cassettes
3. Audio graphics
 - Facsimile
 - Slow-scan television
 - Compressed video
 - Telewriting
 - Videotext
 - Video graphics
4. Laser videodisc
5. Satellite broadcast

Dbē I Dbqbkxj t`tki ugWlqv mtj Kkb

ḡ-ḡkLtb ugWlqv mtj Kkfb Dbē I Dbqbkxj t`kmgfn AvMvgr w`tb wbtgē³ wZbW
w`K m^utK^h_vh_ i aZ;c0v#bi K_v tRvi Mj vq ej v n#Q|

- **For Teaching:** Audio-visual documents, scrud documents and textbooks.
- **For Learning :** Student workbook, evaluation guide, computer data book, telephonic work cells and telematics.
- **For Learner Support:** Telephone, telematics, fax and correspondence.

ḡ-ḡkLtb fneI tZ tKvb tKvb ḡkqK KgRZ@K c0kqY c0vb Ki#Z nte?

ḡ-ḡkLb th#nZzm^u0ZK Kv#j i avi Yv tm#nZzGZ`nel tq mg`K avi Yv c0v#bi Rb`
wb#geWZ e^w3eM#K c0kqY c0v#bi gva`tg `q K#i tZij v ntj mvgWk fite ḡ-ḡkL#bi
YMZgv#bi Dbqb NU#e|

- Administrative staff ranging from manager, planners to junior administrators.
- Those connected with course design and developments including writers, editors, referees, media technicians and producers.
- Those concerned with course presentation including tutors and counsellors.
- Those concerned with student support service, research and evaluation.

Table 9.5-1 : The training model : functions, skills and training needs for distance education

Personnel functions	Stage 1 Basic expertise	Stage 2 Educational application	Stage 3 Distance education application	Stage 4 Specialized extension
1.a. Course designers b. Academics and writers c. Editors and instructional designers d. Media producers	subject knowledge copy editing and design media production	curriculum design and materials development editing and design of educational materials production of educational programmes	design of self-instructional materials editing self-instructional materials multi-media education	teaching own subject at a distance specialist text design skills production for subject specialisms
2. Planners, managers, administrators	management or administration	educational administration	distance education systems	personal function
3. Tutors and counsellors	subject knowledge	teacher training and adult education	teaching at a distance	discipline related teaching techniques
4. Researchers	research techniques	research in education	research in distance education	specialist skills

ikŸi e`iq f iel`r mnthwMZvi cŸqRbxqZv

Collaboration in all areas of distance education is necessary, once institutions give priority to training is considered to be a component of in-house staff development programmes. It is necessary and desirable for four reasons :

- there is a lack of trainers; new institutions lack staff with sufficient experience to train, and established small units may lack training capacity.
- advanced training is specialized, because it applies to small numbers in most institutions, it often needs to take place in inter-institutional groups or through exchanges.
- exchange of experience between institutions is a valuable component of training and could be essential for some categories of staff.
- training at a distance or from self-study packages is an important mode of training to be used as an alternative or complement to other modes of training; since there is a common core of skills and knowledge to be acquired by each category of staff, collaboration in the preparation and use of training materials desirable.



Povšgji`vqb 9

A) msvfjB DEi ckae

1. `i-ukqivi Df`k` ubaf`f`Yi BmyKx Kx?
2. `i-ukqivi uuuUK`ij Bmy,tj v Dfj L Kiab|
3. `i-ukqivi gvb ubqS`fY tKvm`m`Uxq Bmy,tj v Kx?
4. `i-ukqivq ukqiv_x`m`nvqZv tmevi gvb ukfite ubi`cY Kiv hıq?
5. `i-ukqivi mgm`v KZ ai`bi I Kx Kx?
6. `i-ukqivi evn`K mgm`v,tj v Dfj L Kiab|
7. `i-ukqivq ukqiv ukqiv_x`m`u`K`c`U`vMZ ukqiv A`c`qv RıUj tKb?
8. Dbqbkij t`tki `i-ukqivi m`vaviY mgm`v Kx Kx?

A) iPbvij-K ckae

1. `i-ukqivi gly` Bmyngn Av`fj vPbv Kiab|
2. `i-ukL`bi ,YMZgvb ubw`OZKi`fY ersj vt`k I`fcb BDıbf`mıU AvMıgx w`fbi Rb` Kx Kx c`f`c MhY Kti`fQ Zv weeZ Kiab|
3. cvk`f`bi Avj`gv BKej I`fcb BDıbf`mıU `i-ukqive`e`vq Kx Kx beZi w`K msthvRb Kti`fQ?
4. Dbqbkij t`tki m`vaviY mgm`v`mn ersj vt`tki `i-ukqivi gj` mgm`v,tj vi weeiY w`b|

MŠcÄx

1. Aggarwal, JC. Essentials of Examination System, Evaluation, Tests and Measurment, Vikas Publishing House Pvt. Ltd., 1997.
2. Bangladesh Institute of Administration and Management, Institution Management Manual, 1998.
3. Baruett, R., Improving Higher Education, SRHE and Open University Press, Buckingham, 1995.
4. BOU, Personnel Management, 1998.
5. Bollington, Rob, Hopkins, David and West, Mel, An Introduction to Teacher Appraisal, Casell Education Limited, London, 1993.
6. Brew, Angela (ed), Directions in Staff Development, The Society for Research into Higher Education and Open University Press, USA, 1995.
7. Diana Green (ed), Society for Research into Higher Education, Open University Press, 1995.
8. Ellington, Henry and Race, Phil (1993) : Producing Teaching Materials, Kogan page Ltd, London.
9. Gregorio, Herman G., Principles and Methods of Teaching Garotech Publishing, Quezoncity, 1976.
10. Horne, Helen and Pierce, Anthony, A Practical Guide to Staff Development and Appraisal in Schools, Kogan page Limited, 1996.
11. Kaufman, R. and Douglas, Z., Quality Management Plus the Continuous Improvement of Education, Corwin Press, Inc., A Saga Publication Company, California, 1993.
12. Kubiszyn, Tom and Borich, Gary, Educational Testing and Measurement, Harper Collins College Publishers, 1993.
13. Loackwood, Fred, The Design and Production of self instructional Materials, Kogan page limited, London, 1998.
14. Marczely, Bernadette, Personalizing Professional Growth: Staff Development that Works, Crowin Press, Inc., California, 1996.
15. Margatroyd, S. and Colin, M. Open University Press, Buckingham, Philadelphia, 1992.
16. Mullins, Terry W., Staff Development Programs - A Guide to Evaluation, Corwin Press, Inc., California, 1994.
17. Rowntree, Derek, Preparing Materials for Open Distance and Flexible Learning, Kogan Page Limited, London, 1994.
18. Vashist, S. R, (ed), Theory of Educational Evaluation, Anmol Publication Pvt. Ltd., 1994.
19. W. Ave`j AvDqj Lvb I AvegKi iml`xKx, e`e`rcbv, Avexi cveij tKkb, PÄMög|
20. gys` Avbl qvi Avj x: ukLb AwfÄZv ubePb I ukLb mivgMö cYqb : cö_ugK `li - KgRuei n`vÜAvDU|
21. ubtqqvi, cö_ugK ukYv cKvmb I e`e`rcbv cK`Y g`vb`qj , c; 311-337.
22. kvgmjy Kexi I W. Gg Ave`j I nve(1997): ukYvµg cYqb, ᄡ Ae GWKkb, evsj v`k D>gY` nekpe`vj q|

ibNE

- A** Af`Šli xY KgrDbqb tKŠkj - 84
- Av** AvB AvB B uc ubYŷK -176
 Av_ŠmgwRK I i vR%bwZK Dcv`vb-171
 Avŷgwi Kvi cvej K GWžKkb -203
- B** IGNOU-i Kgšiv -199
 Instruction - 118
- D** Dgŷ ukLb -160
 Dgŷ I `i-ukLtbi , YMZ gvtbi avi Yv -163
- G** GKvŷWigK tčŷZ -172
- K** Kgčwi tek -21
 Critical success factors - 43
 ukubK`vj mŷvi wfk b -66
 Kgšiv`b gj`vqb c×wZi mŷve×Zv -69
 KgrDbqb -76
 KgrDbqb chŷ -82
 KgrDbqb gj`vqb -92
 KgrDbqb i , YMZ mPK -93
- M** , YMZgvb tKŠkj -7
 , YMZgvb cwi gvc tKŠkj -47
- U** TQM Model -35
 `i-ukŷ -158
 `i ukŷvi , YMZ tKŠkj -167
 `i ukLtb cŷekwaKvi -174
 `i ukŷvi , YMZ Bmŷ-188
 `i ukŷvi mŷm`v -193
 `i ukLtb chŷ I wguWqv -204
 `i ukŷvi fiel`r mnthwMZv -206
- b** tbZZj,- 15, 136; tbZtZj i wZ - 140
 tbZv ubeŷb -144
 tbZtZj weKvk I Dbqb -145
 tbZvi Kvr -149
 tbZvi D^mebx fiŷKv-150, tbZvi , Yvej -152
- c** c×wZMZe`e`vcbr tKŠkj -32
 tčwMZ tbZZj,-148
 tčŷdkbvj tčŷZ -173
- e** e`w³ chŷq KgrDbqb gŷWj -88
 weifbat`tki ukŷvμg wWRvBb -175
 BOU -Gi Kvŷŷg -201
 weifbat`tki `i-ukŷvi `ewkō` -204
- g** gvb Dbqb i weifbat`K -26
 gvb ubaŷŷY weifPZ weiq -29
- j** j wbs`wi tmm²-181
- k** ukŷv_xŷKw`K Kvŷšiv`b -18
 ukŷv cŷZŷvbi wmwv wbi xŷY -40
 ukŷŷKi Kgšiv`b -46
 ukŷv_xŷ KwZZj- 60
 tKŷKŷ chŷŷY -65
 ukŷv_xŷKZŷ gj`vqb -68
 ukŷv cŷZŷv KgrDbqb -78
 ukLb-ŷKlvbv mŷM -119
 ukLb mŷM i Pbv i wZ -123
 ukLb mŷM i , YMZgvb -124
 ukŷv_xŷmrvqZv tmev -179
- m** mwvš i MŷY -12
 mnKŷŷ i ŷvi v gj`vqb -67
 `i-gj`vqb -67
 `i-ukLb ukŷv DcKi Y -129
 `i-ukLb DcKi ŷYi , YMZ mPK -130